

# MS18 - MSE18

## HYDRAULIC MOTORS

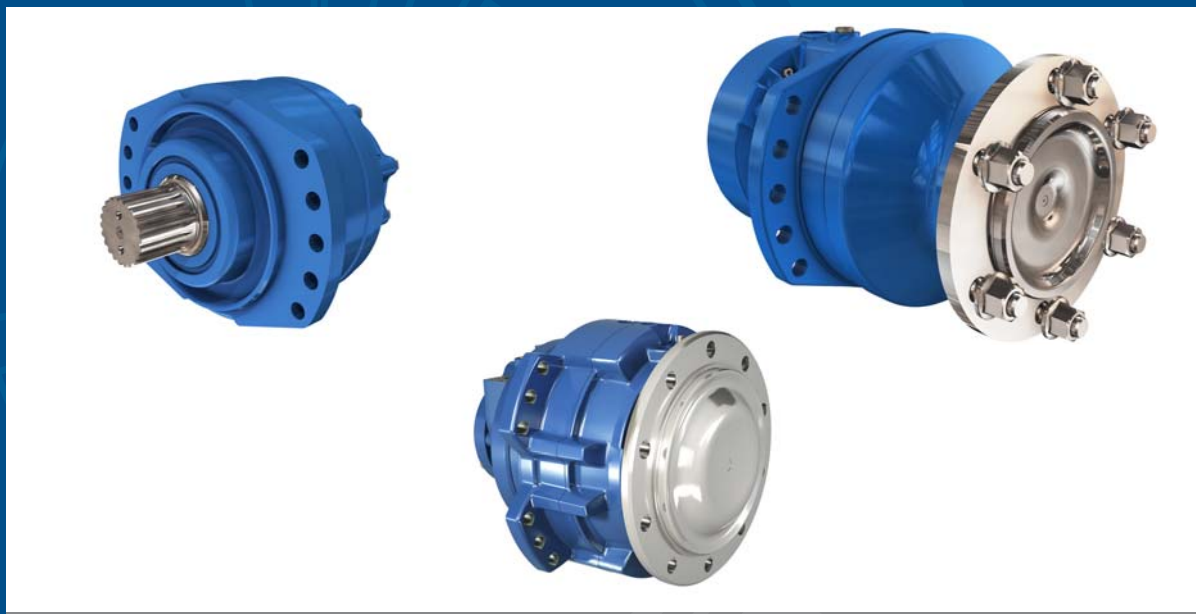

T E C H N I C A L C A T A L O G



# CHARACTERISTICS

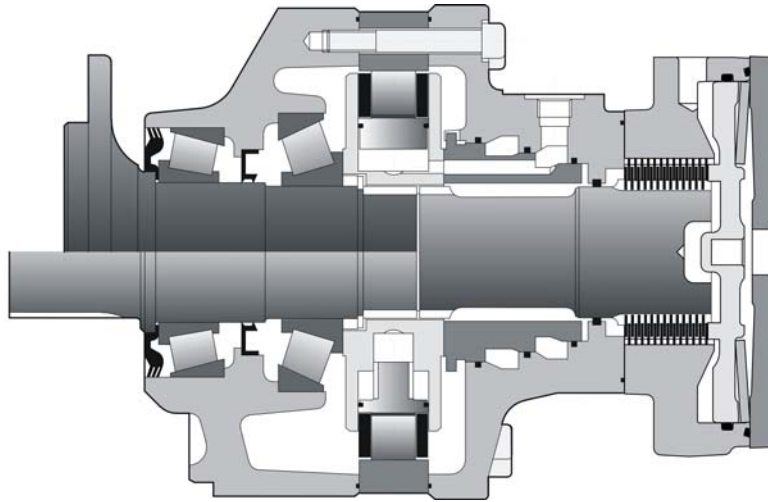

Motor inertia 0.2 kg.m<sup>2</sup>

	C	Displacement		Theoretical torque		Max. power			Max. speed*		Max. pressure bar [PSI]
		1	2	1		1	2	2	1	2	
		cm <sup>3</sup> /tr [cu.in./rev.]	cm <sup>3</sup> /tr [cu.in./rev.]	at 100 bar Nm	at 1000 PSI [lb.ft]	kW [HP]	preferred kW [HP]	non-preferred kW [HP]	tr/min [RPM]	tr/min [RPM]	
Cams with equal lobes	MS18	6	1,091 [66.5]	546 [33.3]	1,735 [882]	70 [94]	47 [63]	35 [47]	170	170	450 [6,527]
		8	1,395 [85.1]	698 [42.5]	2,218 [1,128]				155	160	
		9	1,571 [95.8]	786 [47.9]	2,498 [1,270]				140	155	
		0	1,747 [106.5]	874 [53.3]	2,778 [1,413]				125	150	
		1	1,911 [116.6]	956 [58.3]	3,038 [1,545]				115	135	
	MSE18	2	2,099 [128.0]	1050 [64.0]	3,337 [1,697]	100	125	400 [5,802]			
		0	2,340 [142.7]	1170 [71.4]	3,721 [1,892]	90	110				
		1	2,560 [156.1]	1280 [78.1]	4,070 [2,070]	85	100				
		2	2,812 [171.5]	1406 [85.8]	4,471 [2,274]	75	90				
		Cams with unequal lobes	MS18	P	1,501 [91.5]	874 [53.3] 627 [38.2]	2,387 [1,214]		70 [94]	47 [63]	35 [47]
K	1,501 [91.5]			956 [58.3] 545 [33.2]	2,387 [1,214]	115	135				
D	1,572 [95.9]			1049 [64.0] 523 [31.9]	2,499 [1,271]	100	125				
F	1,650 [100.6]			990 [60.4] 660 [40.3]	2,624 [1,334]	110	135				
A	1,745 [106.4]			1049 [64.0] 698 [42.6]	2,775 [1,411]	100	125				
MSE18	B		1,865 [113.7]	1049 [64.0] 816 [49.8]	2,965 [1,508]	100	125	400 [5,802]			
	P		2,010 [122.6]	1170 [71.4] 840 [51.2]	3,196 [1,625]	90	110				
	K		2,010 [122.6]	1280 [78.1] 730 [44.5]	3,196 [1,625]	85	100				
	D		2,106 [128.4]	1406 [85.8] 700 [42.7]	3,349 [1,703]	75	90				
	F		2,209 [134.7]	1326 [80.9] 883 [53.9]	3,512 [1,786]	85	95				
MSE18	A	2,341 [142.8]	1406 [85.8] 935 [57.0]	3,722 [1,893]	75	90	400 [5,802]				
	B	2,499 [152.4]	1406 [85.8] 1093 [66.7]	3,973 [2,021]	75	90					

- 1 First displacement
- 2 Second displacement

\* See option "M" for higher speed.

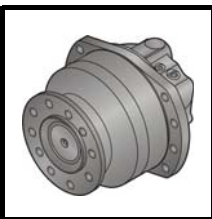
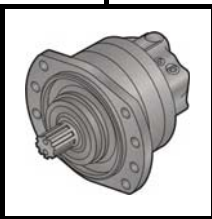
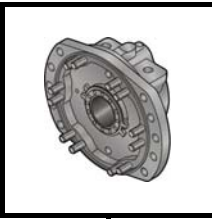
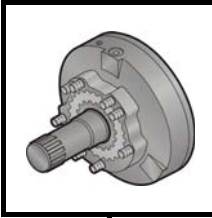
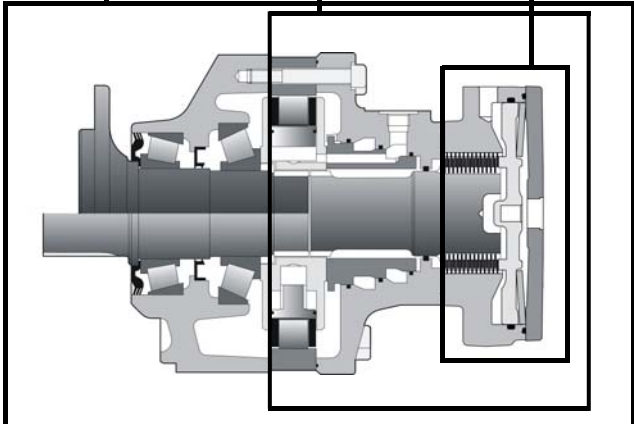

# CONTENT

	<b>MODULARITY</b>	<b>4</b>	Modularity and Model code
	<b>MODEL CODE</b>	<b>6</b>	
	<b>WHEEL MOTOR</b>	<b>8</b>	Wheel motor
	Dimensions for standard (1210) 2-displacement motor	9	
	Support types	10	
	Dimensions for standard (FT30) 1-displacement motor	11	
	Dimensions for standard (FT30) 2-displacement motor	11	
	Dimensions for standard (P310) 1-displacement motor	12	
	Dimensions for standard (P310) 2-displacement motor	12	
	Dimensions for standard (R210) 1-displacement motor	13	
	Dimensions for standard (R210) 2-displacement motor	13	
	Dimensions for standard (U210) 1-displacement motor	14	
	Dimensions for standard (U210) 2-displacement motor	14	
	Load curves	15	
	Load curves (continued)	16	
	Support types (continued)	17	
Load curves (continued)	18		
	<b>SHAFT MOTOR</b>	<b>19</b>	Shaft motor
	Dimensions for standard (2A50) 1-displacement motor	19	
	Dimensions for standard (2A50) 2-displacement motor	19	
	Support types	20	
	Splined coupling	20	
Load curves	21		
	<b>VALVING SYSTEMS AND HYDROBASES</b>	<b>23</b>	Valving systems and hydrobases
	Dimensions for 1-displacement valving	23	
	Dimensions for other valving systems	24	
	Dimensions for 1-displacement valving	28	
	Dimensions for 2-displacement valving	28	
	Exchange	29	Brake
	Chassis mountings	29	
	Hydraulic connections	30	
	Efficiency	32	
	<b>BRAKES</b>	<b>33</b>	
Rear brake	33	Options	
C27™ Combined brake	34		
P27™ Parking brake	35		
P20™ Parking brake	36		
S20™ Service brake	37		
	<b>OPTIONS</b>	<b>39</b>	



# MODUL

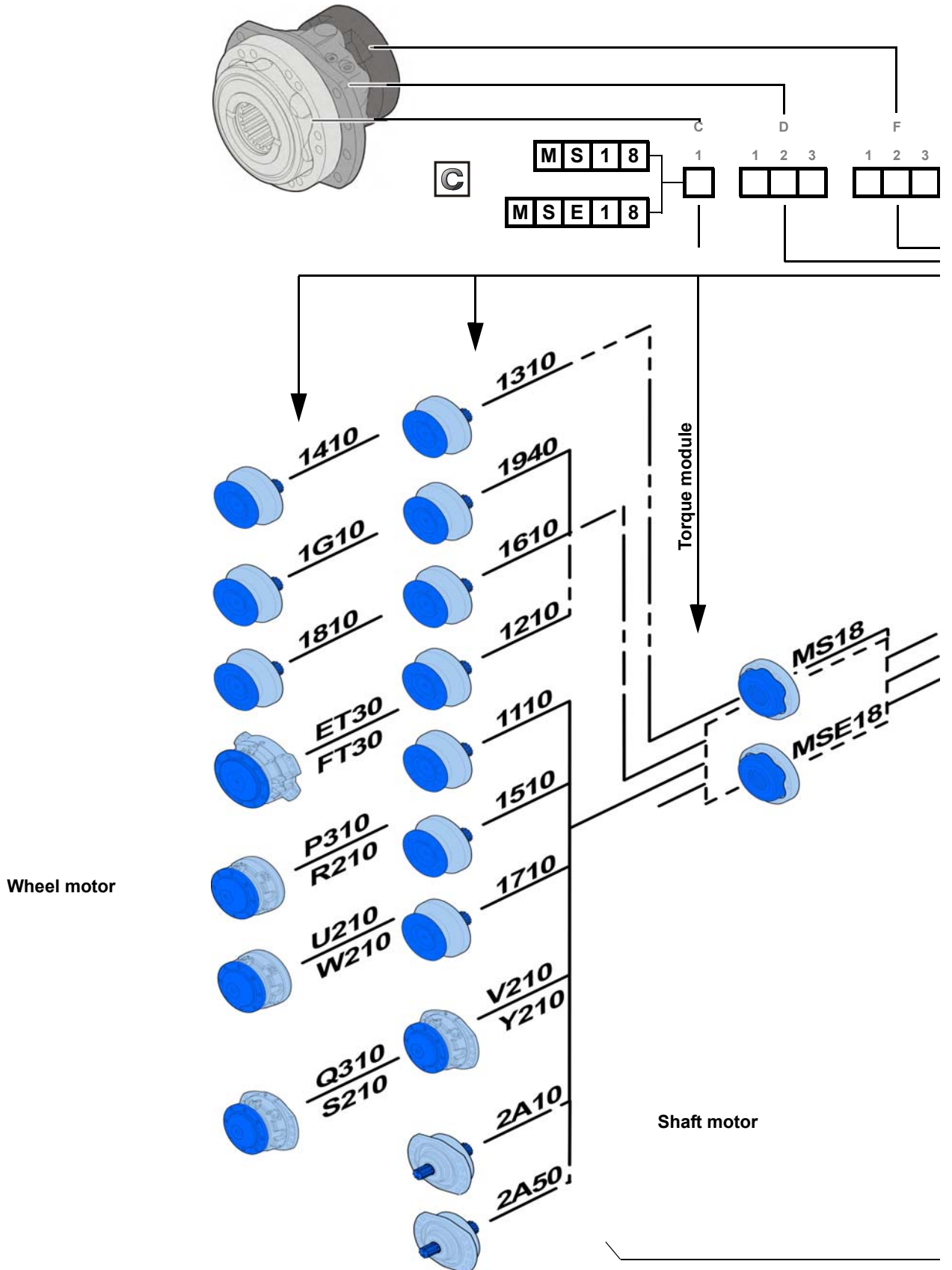



# MODULARITY

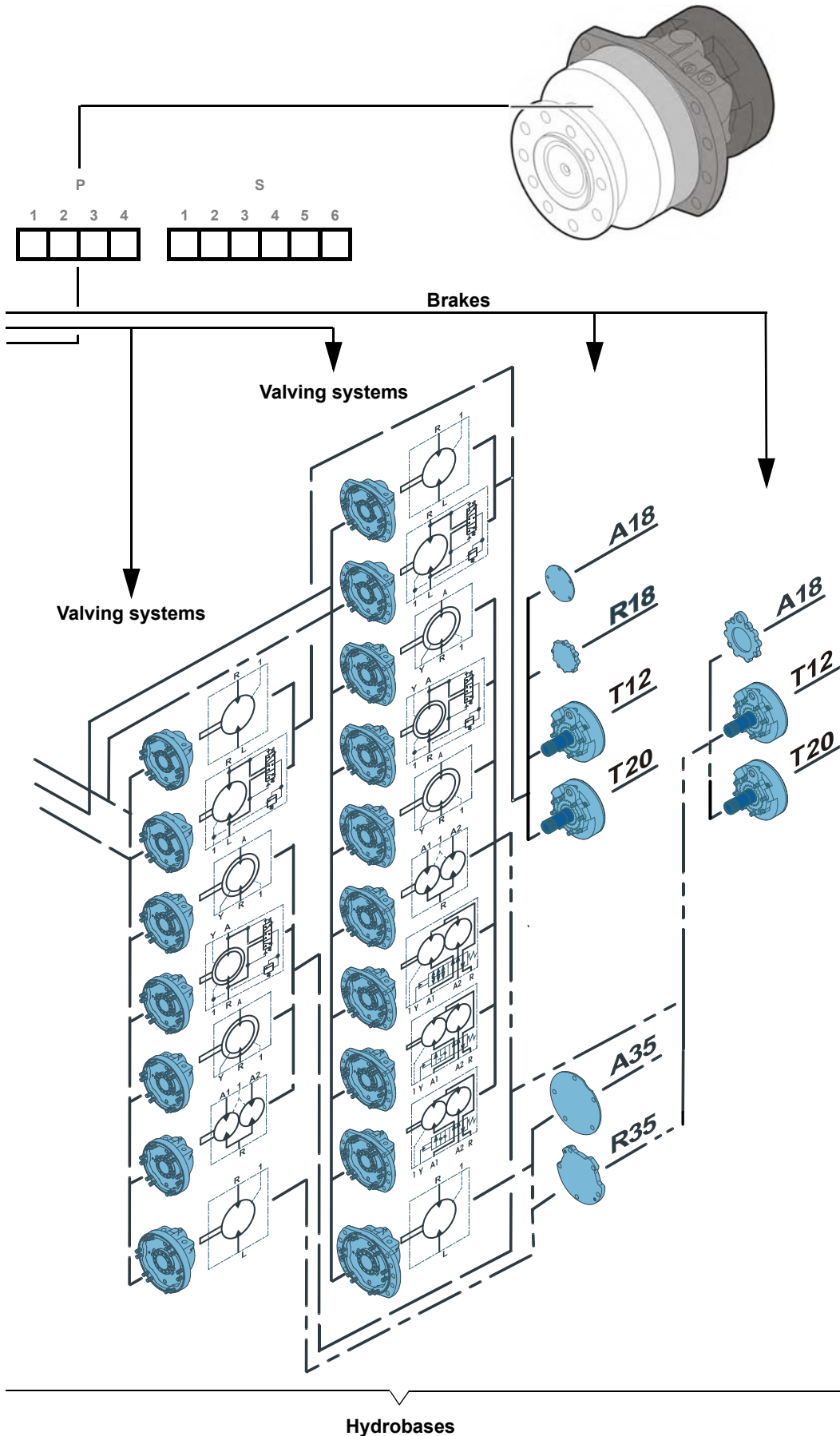

Modularity and Model code
Wheel motor
Shaft motor
Valving systems and hydrobases
Brake
Options



# MODEL

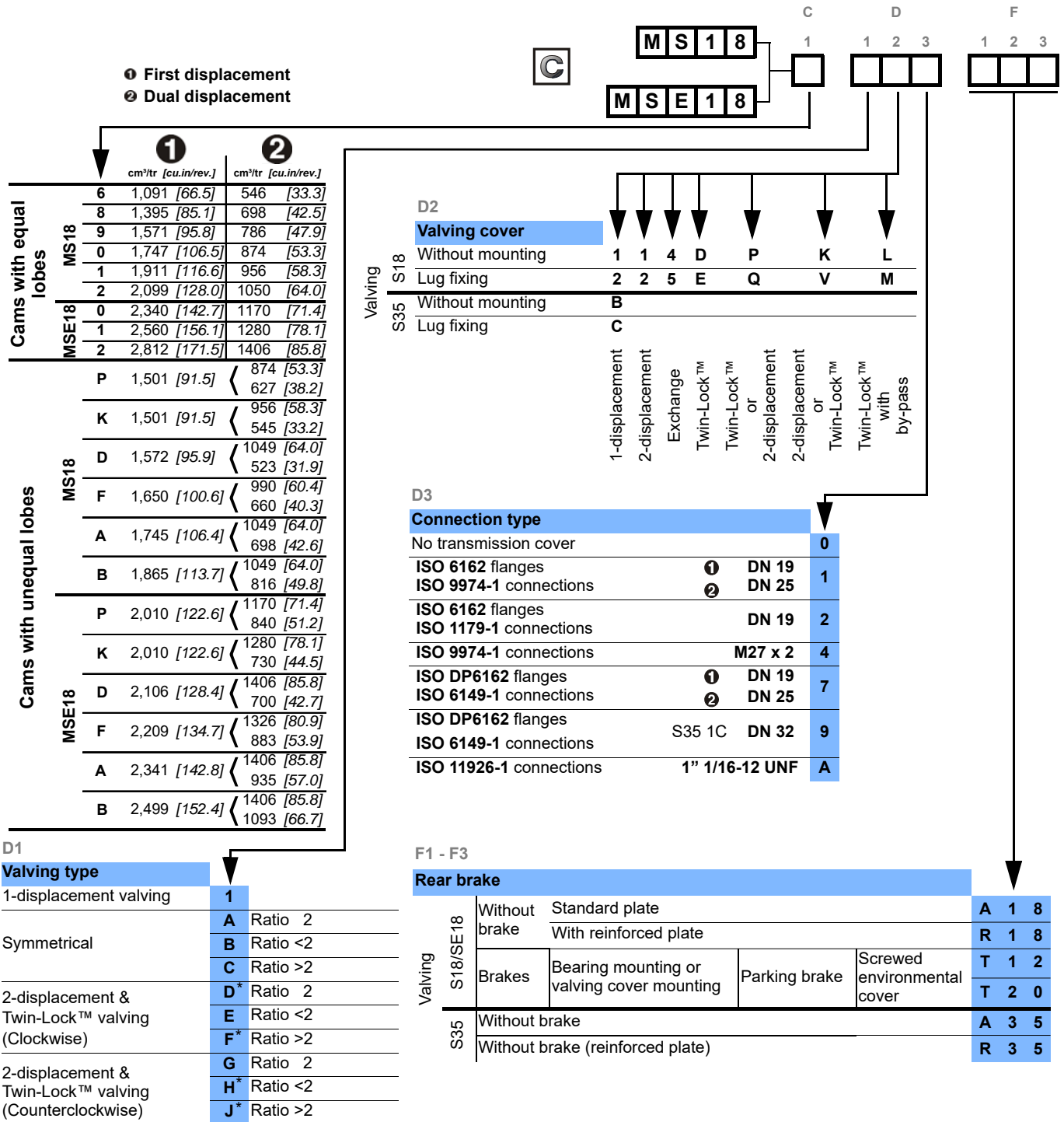
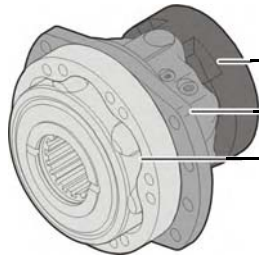

\* For Boosted Braking™ (option U becomes mandatory).





# CODE

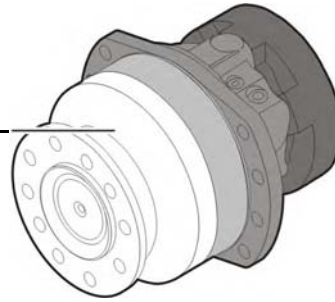

**P1 Front unit**

0	Without bearing support		
1	Without mounting		
2	Lug mounting		
E	C27™	valving cover fixation	
F	C27™	chassis fixation	
P	P27™	valving cover fixation	
Q	P27™	chassis fixation	
R	P20™	valving cover fixation	
S	P20™	chassis fixation	
U	S20™	valving cover fixation	single control command
V		chassis fixation	
W	S20™	valving cover fixation	double control command
Y		chassis fixation	

**P2 Bearing support**

0	Without shaft
1	10 x Ø24 on Ø225
2	8 x Ø22 on Ø275 (Standard for S20/P20™ brake)
3	10 x Ø24 on Ø225 (Standard for P27™ brake)
5	10 x Ø24 on Ø335 (for studs length of 80 mm)
T	10 x Ø24 on Ø335 (Standard for C27™ brake) (for studs length of 65 mm)
6	10 x Ø24 on Ø225
7	12 x Ø24 on Ø275
8	18 x M16 on Ø254
9	8 x M22 on Ø275
G	Support without drum brake
A	For male shaft bearing support

**P3 Shaft type**

1	Without studs
2	With studs + nuts
3	With studs
4	M threaded holes

**Male shafts**

1	NF E22-141 splines
5	DIN 5480 splines

**S1 - S6 Options**

0	Without options or adaptations
1	Fluorinated elastomer seals
2	T4 speed sensor (without rotation direction)
3	Brake environmental cover without plug
5	Drainage
6	Industrial bearing support
7	Diamond™
8	Predisposition for speed sensor
A	Hollow shaft
B	Drain on the bearing support
C	Abrasive environment
D	Special paint or without paint
E	Reinforced sealing
G	Special wheel rim mounting
H	High performance
J	Surface heat treatment of the shaft
M	High speed
S	TR speed sensor (digital rotation direction)
Q	TD speed sensor (two phase shifted frequencies)
U	Boosted Braking™

Modularity and Model code

Wheel motor

Shaft motor

Valving systems and hydrobases

Brake

Options



**Methodology :**

This document is intended for manufacturers of machines that incorporate Poclain Hydraulics products. It describes the technical characteristics of Poclain Hydraulics products and specifies installation conditions that will ensure optimum operation.

This document includes important comments concerning safety. They are indicated in the following way:



**Safety comment.**

This document also includes essential operating instructions for the product and general information. These are indicated in the following way:



**Essential instructions.**



**General information.**



**Information on the model number.**



**Weight of component without oil.**



**Volume of oil.**



**Units.**



**Tightening torque.**



**Screws.**



**Information intended for Poclain-Hydraulics personnel.**

The views in this document are created using metric standards.

The dimensional data is given in mm and in inches (inches are given in brackets in italics).



**Dimensions for standard (1210) 1-displacement motor**

	120 kg [264 lb]	170 kg [374 lb]
	3.00 L [180 cu.in]	2.50 L [150 cu.in]

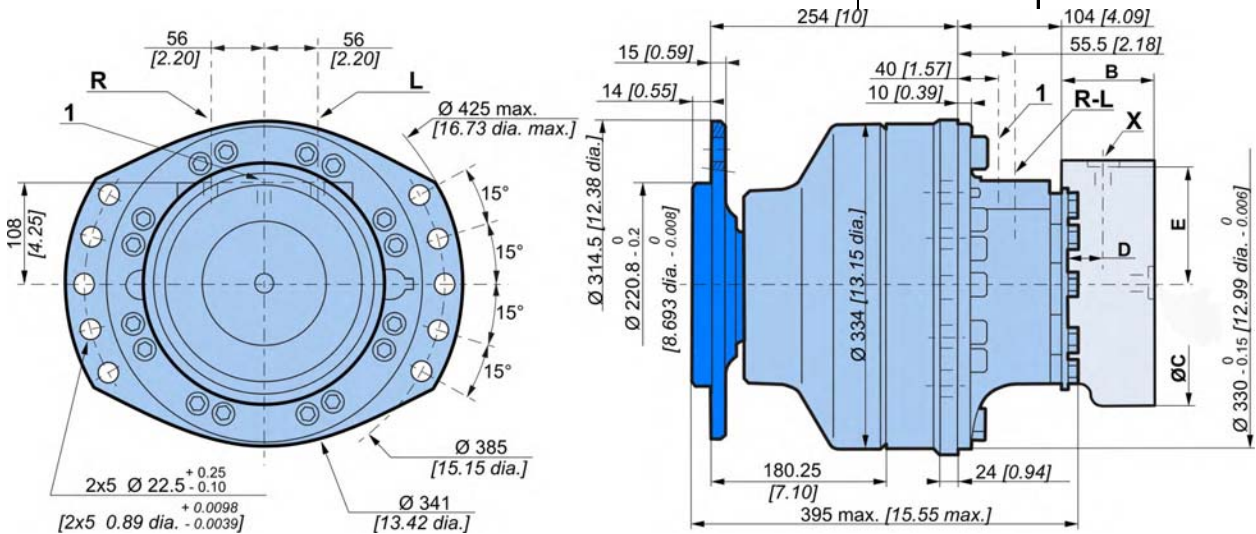
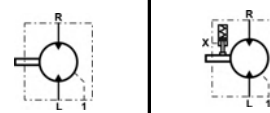





# WHEEL MOTOR

## Dimensions for standard (1210) 2-displacement motor

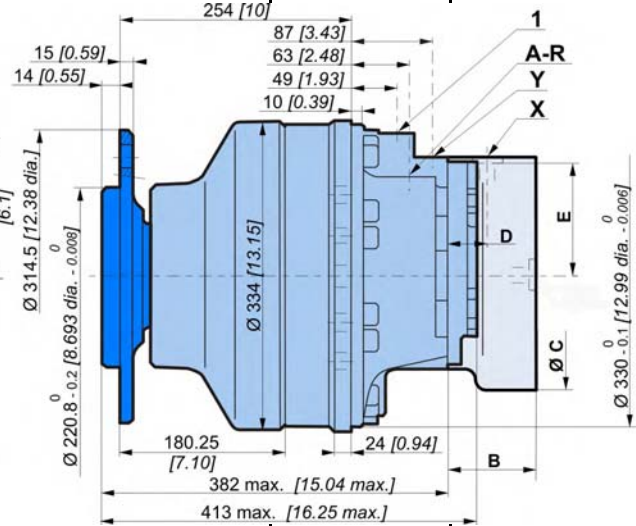
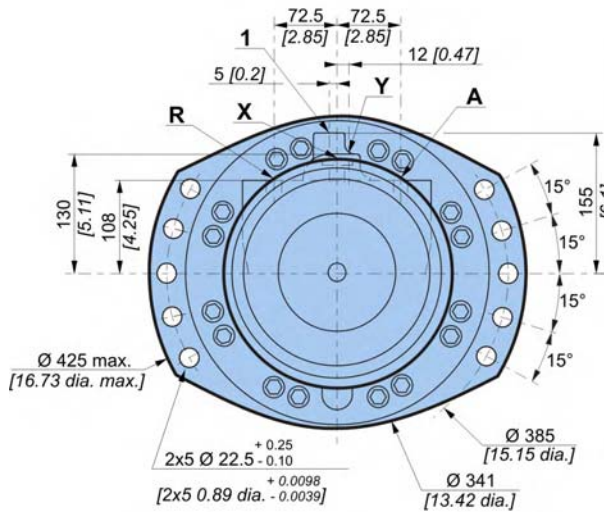

	130 kg [286 lb]	160 kg [352 lb]
	3.00 L [180 cu.in]	2.50 L [150 cu.in]

## Dimensions for standard (1210) Twin-Lock™

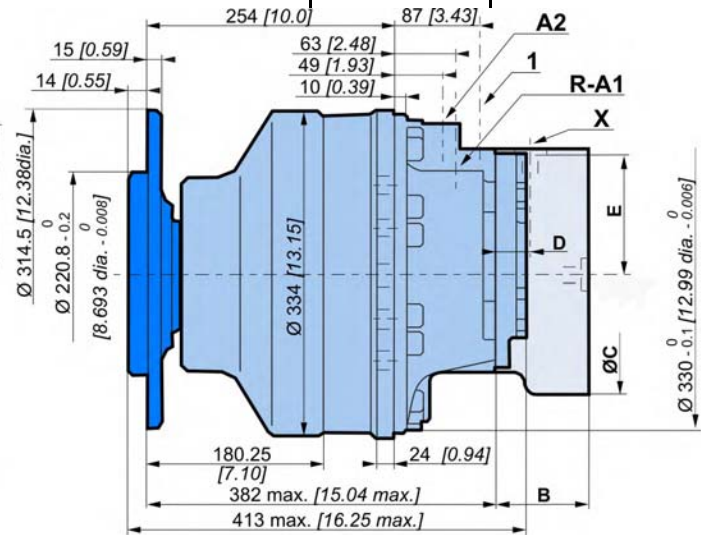
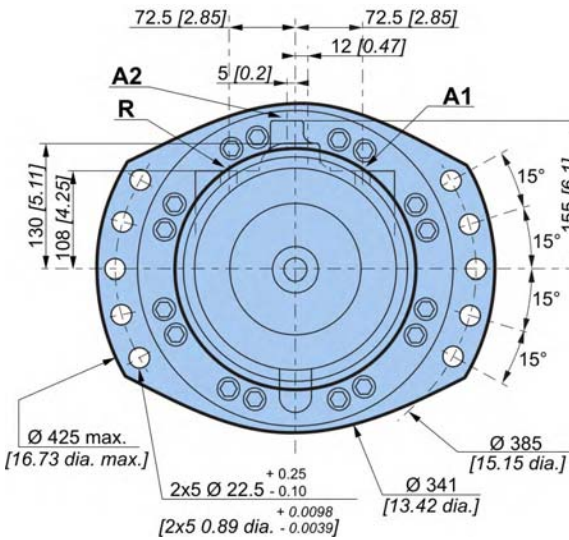

	130 kg [286 lb]	160 kg [352 lb]
	3.00 L [180 cu.in]	2.50 L [150 cu.in]



Also see 'Valving systems and hydrobases' section (thumbnail opposite).

	T12	T20
B	92.5 [3.64]	115 [4.53]
Ø C	273.6 [10.77]	282 [11.10]
D	24.5 [0.96]	45 [1.77]
E	128.5 [5.06]	128.5 [5.06]



Also see "Brake" section (thumbnail opposite).

Modularity and Model code

Wheel motor

Shaft motor

Valving systems and hydrobases

Brake

Options



Support types

	C				D			F			P				S					
	1				1 2 3			1 2 3			1 2 3 4				1 2 3 4 5 6					
	MS18				MSE18															
	A	B	C	D	E	N	Wheel rim mountings	L												
	mm [in]	mm [in]	mm [in]	mm [in]	mm [in]	mm [in]		mm [in]												
	Ø 175,7 [6,92 dia.]	Ø 225 [8,86 dia.]	Ø 265 [10,43 dia.]	253,45 [9,98]	Ø 334 [13,15 dia.]	Ø 24 [0,94 dia.]	10 x M22x1.5	14 [0,55]												
	Ø 220,7 [8,69 dia.]	Ø 275 [10,83 dia.]	Ø 314 [12,36 dia.]	253,25 [9,97]	Ø 334 [13,15 dia.]	Ø 22 [0,87 dia.]	8 x M20x1.5	14 [0,55]												
	Ø 220,7 [8,69 dia.]	Ø 275 [10,83 dia.]	Ø 314 [12,36 dia.]	253,25 [9,97]	Ø 334 [13,15 dia.]	Ø 24 [0,94 dia.]	12 x M22x1.5	18 [0,71]												
	Ø 175,7 [6,92 dia.]	Ø 225 [8,86 dia.]	Ø 276 [10,87 dia.]	208,75 [8,22]	Ø 334 [13,15 dia.]	Ø 24 [0,94 dia.]	10 x M22x1.5	14 [0,55]												
	Ø 220,7 [8,69 dia.]	Ø 254 [10,00 dia.]	Ø 285 [11,22 dia.]	163,2 [6,43]	Ø 334 [13,15 dia.]	18 x M16x1.5	-	15 [0,59]												
	Ø 280,7 [11,05 dia.]	Ø 335 [13,19 dia.]	Ø 382 [15,04 dia.]	292,2 [11,50]	Ø 334 [13,15 dia.]	Ø 24 [0,94 dia.]	10 x M22x1.5	25 [0,98]												
	Ø 175,7 [6,92 dia.]	Ø 225 [8,86 dia.]	Ø 265 [10,43 dia.]	208,75 [8,22]	Ø 334 [13,15 dia.]	Ø 24 [0,94 dia.]	10 x M22x1.5	16,5 [0,65]												
	Ø 220,7 [8,69 dia.]	Ø 275 [10,83 dia.]	Ø 314 [12,36 dia.]	208,8 [8,22]	Ø 334 [13,15 dia.]	Ø 22 [0,87 dia.]	8 x M20x1.5	18 [0,71]												
	Ø 280,7 [11,05 dia.]	Ø 335 [13,19 dia.]	Ø 385 [15,16 dia.]	301,0 [11,85]	Ø 334 [13,15 dia.]	Ø 24 [0,94 dia.]	10 x M22x1.5	14 [0,55]												

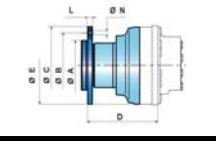
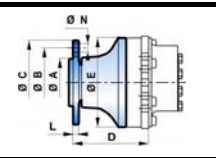
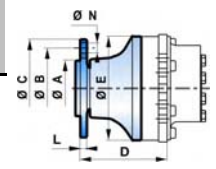

The supports in gray must not be assembled with an MSE hydrobase.

Studs

		P	C min.	C max.	D	Class
		mm [in]	mm [in]	mm [in]	mm [in]	
Various studs	M16 x 2	50 [1.97]	5 [0.20]	17.75 [0.70]	21 [0.83]	12.9
	M20 x 1.5	60 [2.36]		20 [0.79]	25 [0.98]	
	M20 x 1.5	70 [2.76]		27 [1.06]	25 [0.98]	
	M22 x 1.5	65 [2.56]		24 [0.94]	26 [1.02]	
	M22 x 1.5	80 [3.15]		29 [1.14]	26 [1.02]	
Screws	M16 x 1.5	-	-	-	-	10.9
	M20 x 1.5	-	-	-	-	

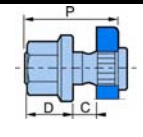

See generic installation motors N°B59689D.



Dimensions for standard (FT30) 1-displacement motor

215 kg [473 lb]

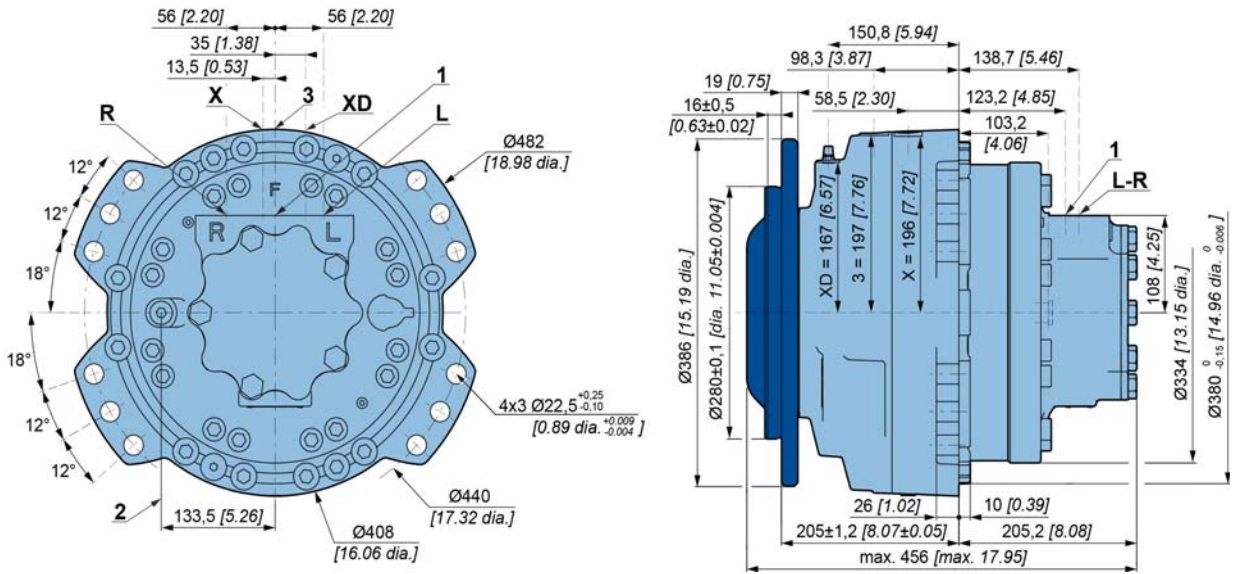

Modularity and Model code

Wheel motor

Dimensions for standard (FT30) 2-displacement motor

236 kg [519 lb]

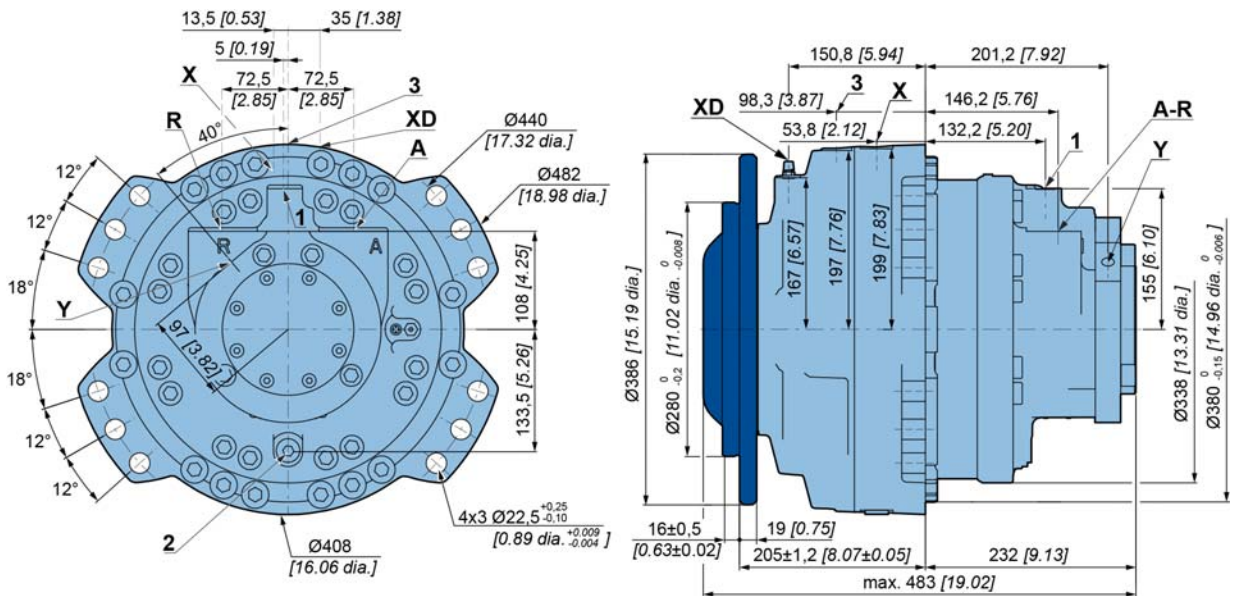

Shaft motor

Valving systems and hydrobases

Brake

Brake bearing support orientation

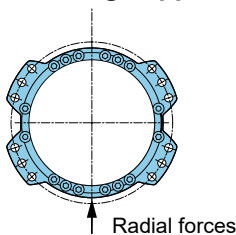

**Recommended orientation:**  
Radial forces to be oriented along the brake bearing support axis.



**Warn the end user in the user documentation to perform an inspection of the shaft after any abnormal shock at wheel.**

Options





Dimensions for standard (P310) 1-displacement motor

220 kg [485 lb]

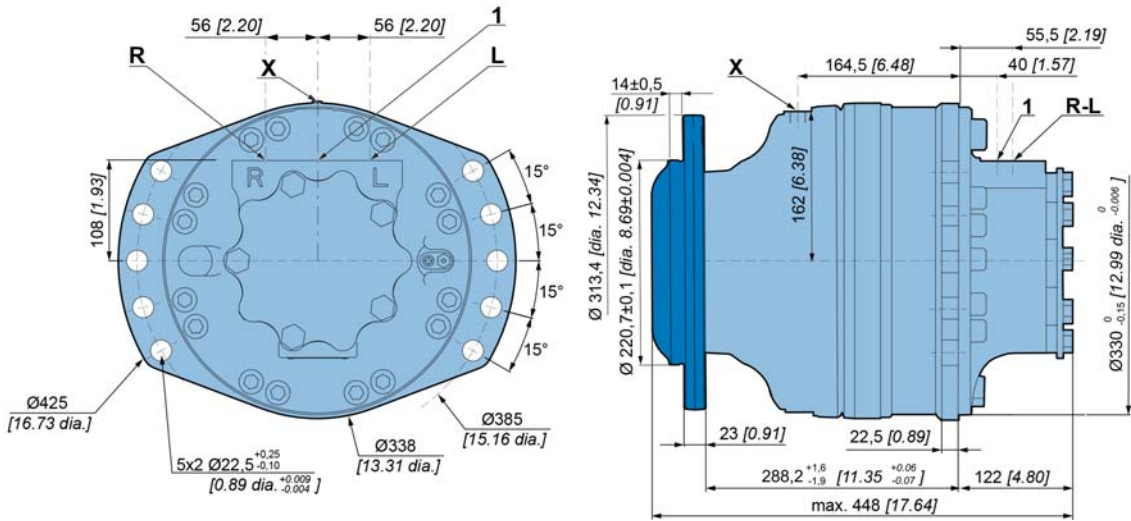

Dimensions for standard (P310) 2-displacement motor

222 kg [489 lb]

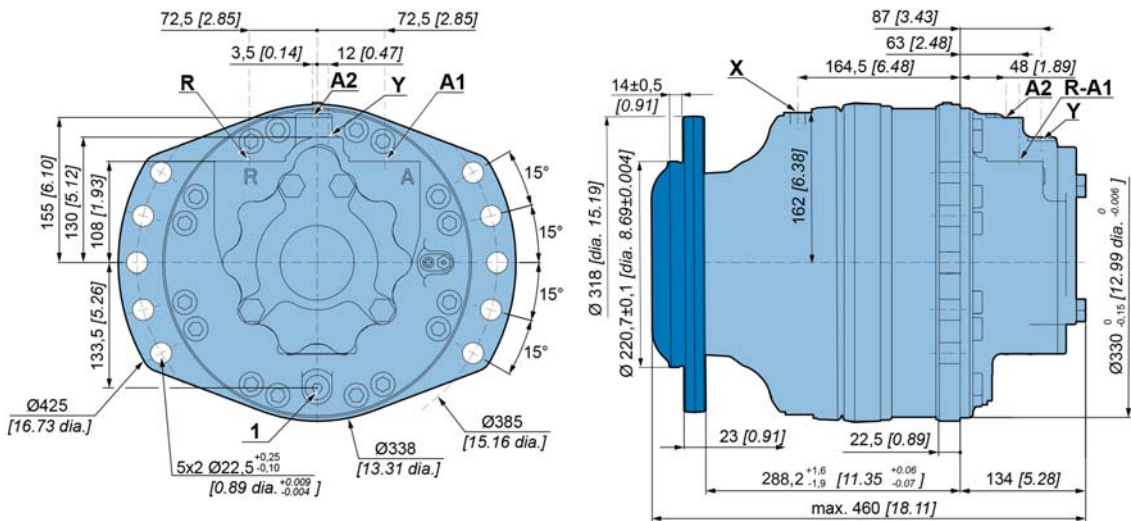

Also see 'Valving systems and hydrobases' section (thumbnail opposite).



Also see "Brake" section (thumbnail opposite).



Dimensions for standard (R210) 1-displacement motor

170 kg [375 lb]

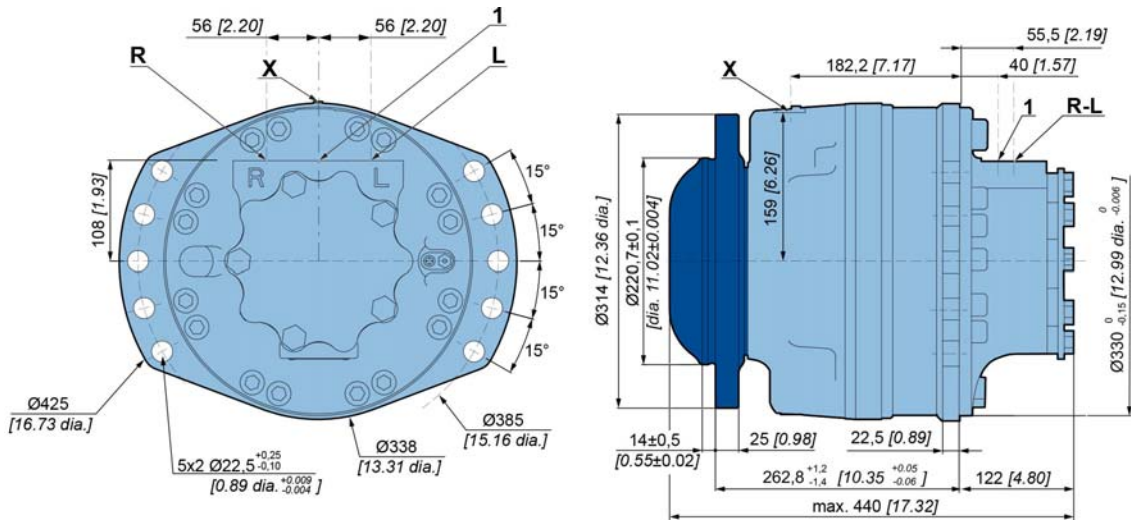

Dimensions for standard (R210) 2-displacement motor

180 kg [397 lb]

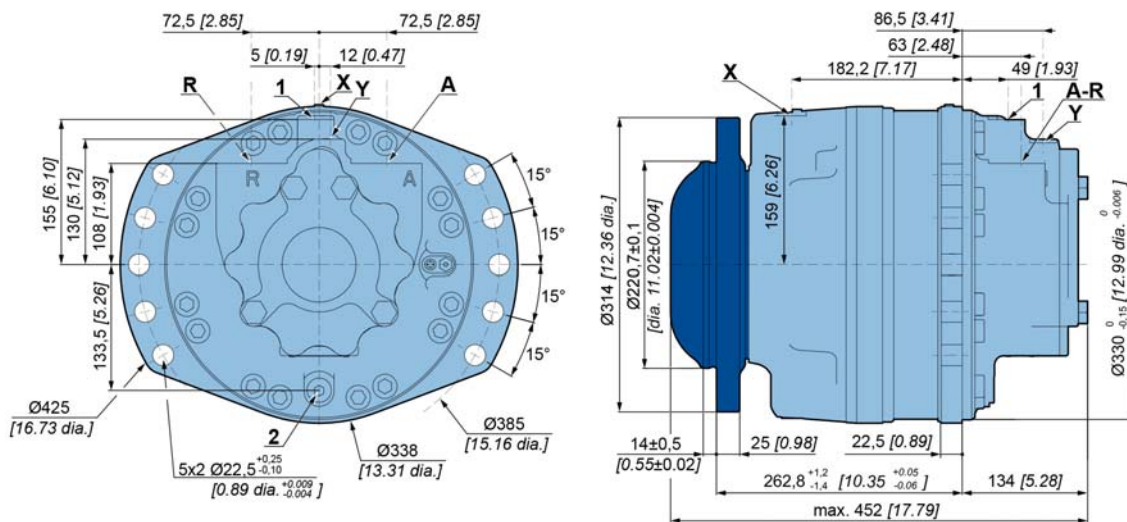

Also see 'Valving systems and hydrobases' section (thumbnail opposite).



Also see "Brake" section (thumbnail opposite).

Modularity and Model code

Wheel motor

Shaft motor

Valving systems and hydrobases

Brake

Options



**Dimensions for standard (U210) 1-displacement motor**

 170 kg [375 lb]

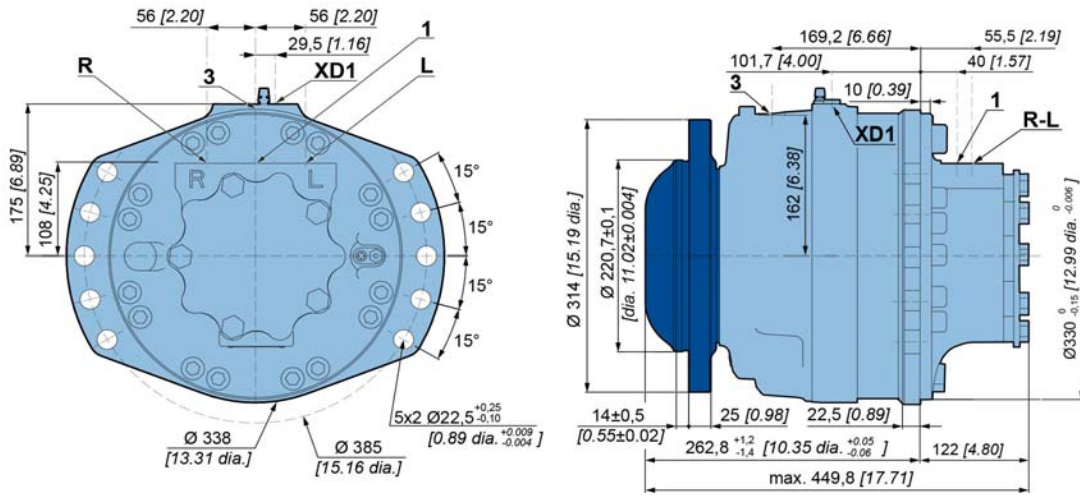

**Dimensions for standard (U210) 2-displacement motor**

 180 kg [397 lb]

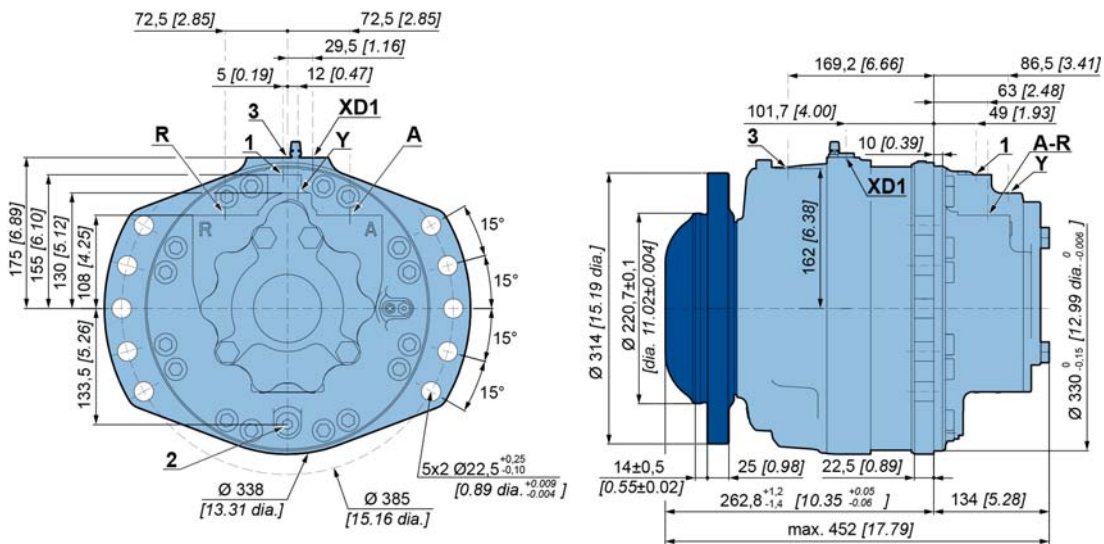

Also see 'Valving systems and hydrobases' section (thumbnail opposite).



Also see "Brake" section (thumbnail opposite).





Load curves

Permissible radial loads

Test conditions :

Static : 0 tr/min [0 RPM] 0 bar [0 PSI]

Dynamic : 0 tr/min [0 RPM], code 0 displacement, without axial load at max. torque

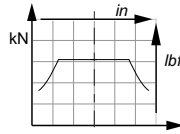

Service life of bearings

Test conditions :

L : Millions B10 revolutions at 150 bars (average pressure), with 25 cSt fluid, code 0 displacement, without axial load.

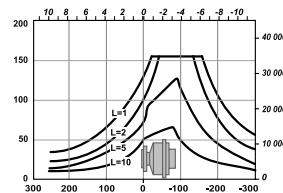
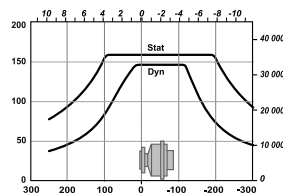
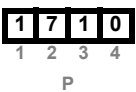
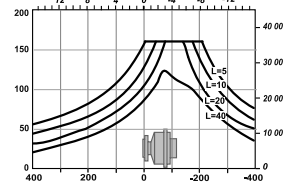
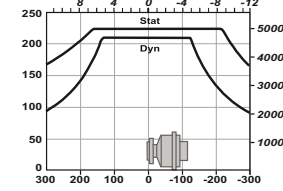
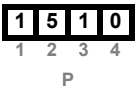
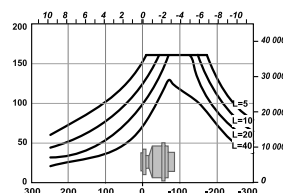
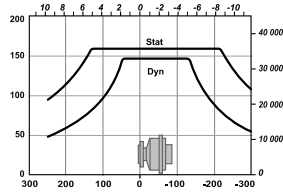
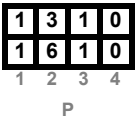
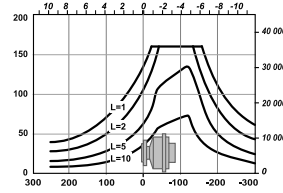
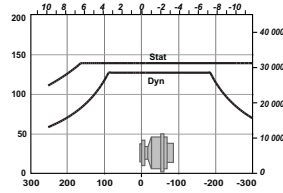
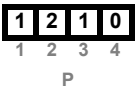
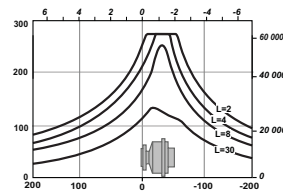
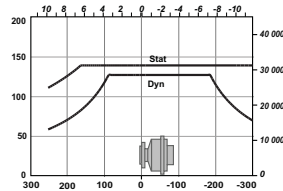
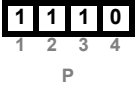

The service life of the components is influenced by the pressure. You must check that the combination of forces applied (Axial load / Radial load) is compatible with the permissible loads for the components, and that the resulting service lives of these components complies with the application's specifications. For an accurate calculation, consult your Poclain Hydraulics application engineer.

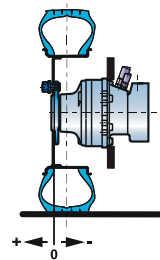

Modularity and Model code

Wheel motor

Shaft motor

Valving systems and hydrobases

Brake

Options



### Load curves (continued)

#### Permissible radial loads

Test conditions :

**Static** : 0 tr/min [0 RPM] 0 bar [0 PSI]

**Dynamic** : 0 tr/min [0 RPM], code 0 displacement, without axial load at max. torque

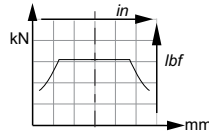

#### Service life of bearings

Test conditions :

**L** : Millions B10 revolutions at 150 bars (average pressure), with 25 cSt fluid, code 0 displacement, without axial load.

**1 9 1 0**  
1 2 3 4  
P

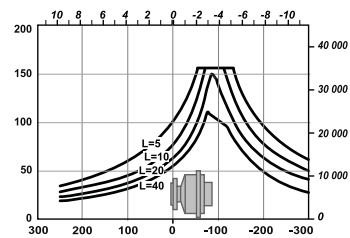
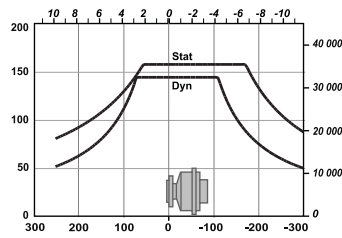

**E T 3 0**  
1 2 3 4  
P

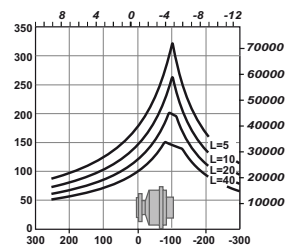
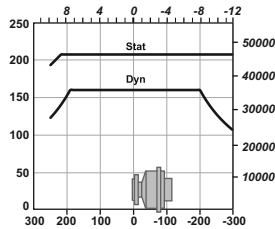

**F T 3 0**  
1 2 3 4  
P

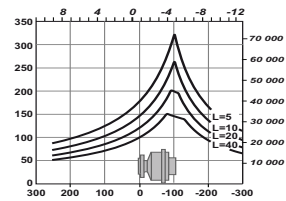
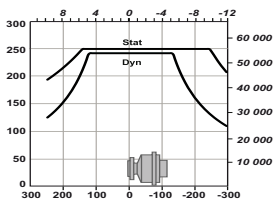

**P 3 1 0**  
1 2 3 4  
P

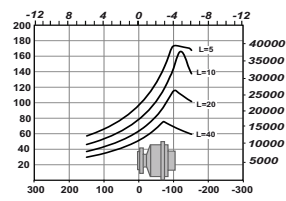
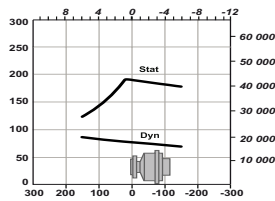

**Q 3 1 0**  
1 2 3 4  
P

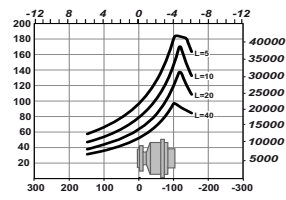
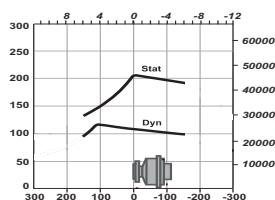

The service life of the components is influenced by the pressure. You must check that the combination of forces applied (Axial load / Radial load) is compatible with the permissible loads for the components, and that the resulting service lives of these components complies with the application's specifications. For an accurate calculation, consult your Poclain Hydraulics application engineer.

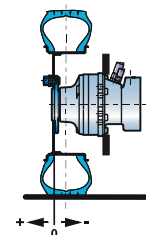



Support types (continued)

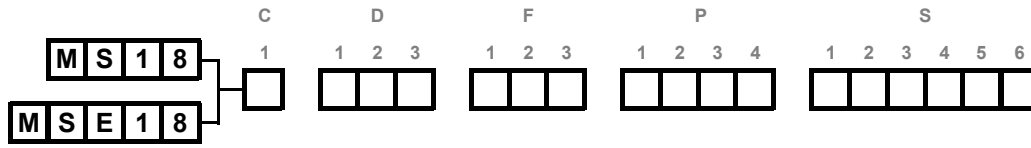

	A mm [in]	B mm [in]	C mm [in]	D mm [in]	E mm [in]	N mm [in]	Wheel rim mountings	L mm [in]	
	Ø 280.7 [11.05 dia.]	Ø 335 [13.19 dia.]	Ø 386 [15.20 dia.]	317.0 [12.48]	Ø 405 [15.94 dia.]	Ø 24 [0.94 dia.]	10 x M22x1.5	19 [0.75]	
	Ø 280.7 [11.05 dia.]	Ø 335 [13.19 dia.]	Ø 386 [15.20 dia.]	205.0 [8.07]	Ø 408 [16.06 dia.]	Ø 24 [0.94 dia.]	10 x M22x1.5	19 [0.75]	
	Ø 220.7 [8.69 dia.]	Ø 275 [10.83 dia.]	Ø 313 [12.34 dia.]	288.2 [11.34]	Ø 338.5 [13.33 dia.]	Ø 22 [0.87 dia.]	8 x M20x1.5	23 [0.91]	
	Ø 220.7 [8.69 dia.]	Ø 275 [10.83 dia.]	Ø 313 [12.34 dia.]	205 [8.07]	Ø 338.5 [13.33 dia.]	Ø 22 [0.87 dia.]	8 x M20x1.5	23 [0.91]	
	Ø 220.7 [8.69 dia.]	Ø 275 [10.83 dia.]	Ø 314 [12.36 dia.]	262.8 [10.35]	Ø 339 [13.35 dia.]	Ø 22 [0.87 dia.]	8 x M20x1.5	25 [0.98]	
	Ø 220.7 [8.69 dia.]	Ø 275 [10.83 dia.]	Ø 314.0 [12.36 dia.]	262.8 [10.35]	Ø 338 [13.31 dia.]	Ø 22 [0.87 dia.]	8 x M20x1.5	25 [0.98]	
	Ø 220.7 [8.69 dia.]	Ø 275 [10.83 dia.]	Ø 314.0 [12.36 dia.]	262.8 [10.35]	Ø 338 [13.31 dia.]	Ø 22 [0.87 dia.]	8 x M20x1.5	25 [0.98]	
	Ø 220.7 [8.69 dia.]	Ø 275 [10.83 dia.]	Ø 314 [12.36 dia.]	177.6 [6.99]	Ø 338 [13.31 dia.]	Ø 22 [0.87 dia.]	8 x M20x1.5	25 [0.98]	
	Ø 220.7 [8.69 dia.]	Ø 275 [10.83 dia.]	Ø 314.0 [12.36 dia.]	177.6 [6.99]	Ø 338 [13.31 dia.]	Ø 22 [0.87 dia.]	8 x M20x1.5	25 [0.98]	
	Ø 220.7 [8.69 dia.]	Ø 275 [10.83 dia.]	Ø 314.0 [12.36 dia.]	177.6 [6.99]	Ø 338 [13.31 dia.]	Ø 22 [0.87 dia.]	8 x M20x1.5	25 [0.98]	



Also see "Brake" section (thumbnail opposite).

Modularity and  
Model code

Wheel motor

Shaft motor

Valving systems  
and hydrobases

Brake

Options



### Load curves (continued)

#### Permissible radial loads

Test conditions :

**Static** : 0 tr/min [0 RPM] 0 bar [0 PSI]

**Dynamic** : 0 tr/min [0 RPM], code 0 displacement, without axial load at max. torque

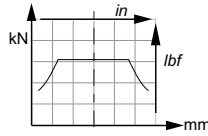

#### Service life of bearings

Test conditions :

**L** : Millions B10 revolutions at 150 bars (average pressure), with 25 cSt fluid, code 0 displacement, without axial load.

**R 2 1 0**  
1 2 3 4  
P

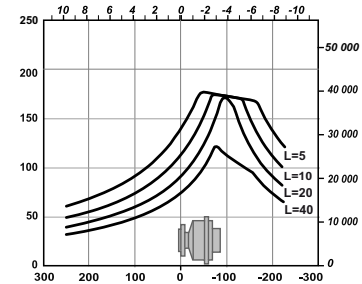
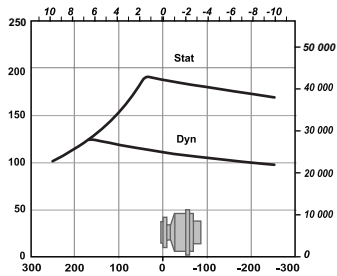

**S 2 1 0**  
1 2 3 4  
P

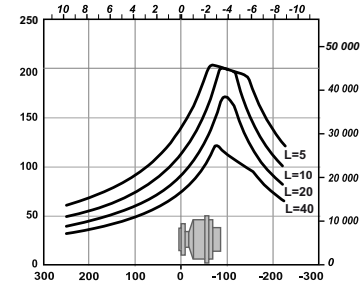
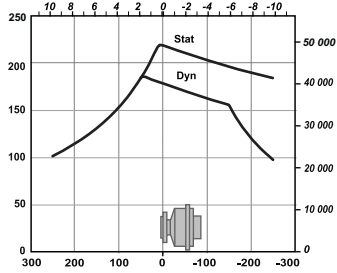

**U 2 1 0**  
**W 2 1 0**  
1 2 3 4  
P

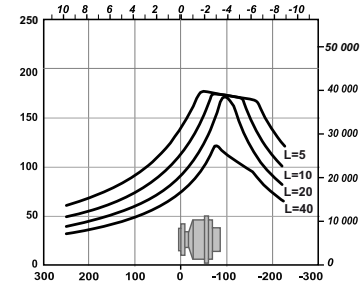
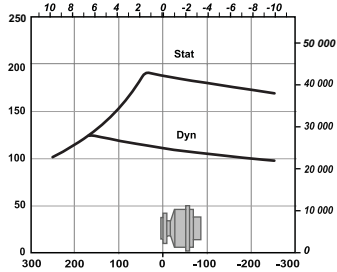

**V 2 1 0**  
**Y 2 1 0**  
1 2 3 4  
P

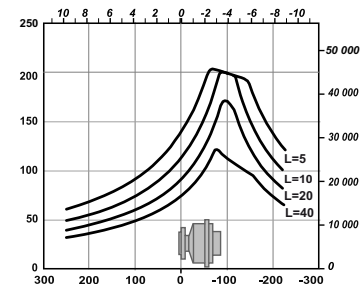
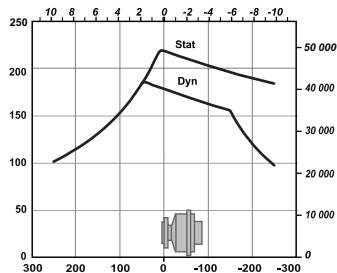

The service life of the components is influenced by the pressure. You must check that the combination of forces applied (Axial load / Radial load) is compatible with the permissible loads for the components, and that the resulting service lives of these components complies with the application's specifications. For an accurate calculation, consult your Poclain Hydraulics application engineer.

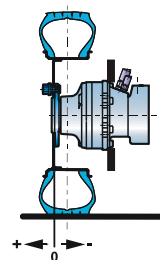



# SHAFT MOTOR

## Dimensions for standard (2A50) 1-displacement motor

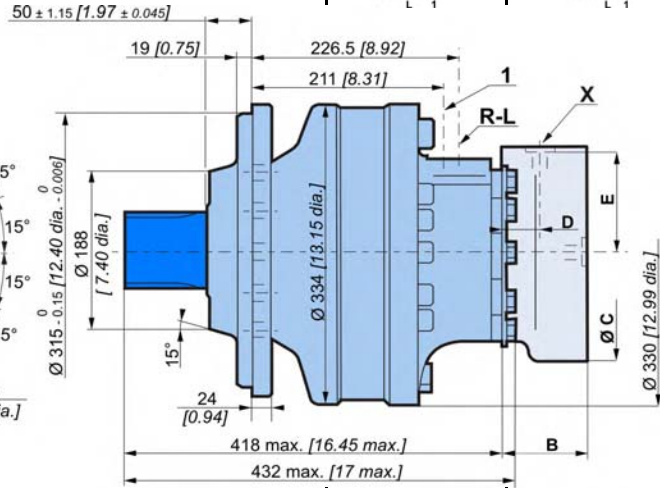
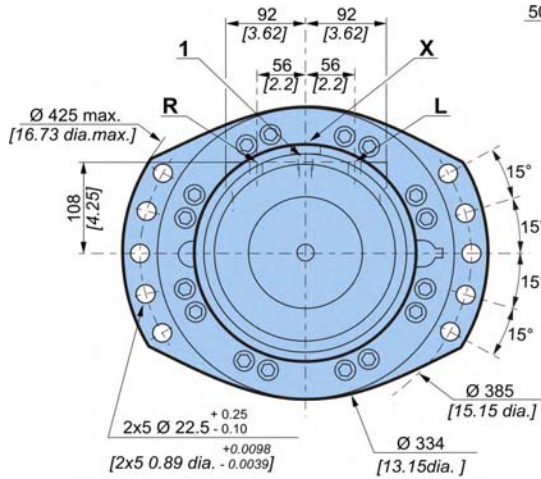

	112 kg [246 lb]	142 kg [312 lb]
	3.00 L [180 cu.in]	2.50 L [150 cu.in]

## Dimensions for standard (2A50) 2-displacement motor

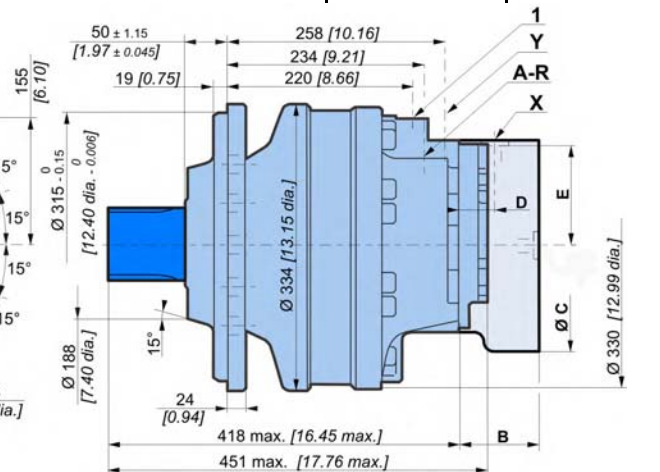
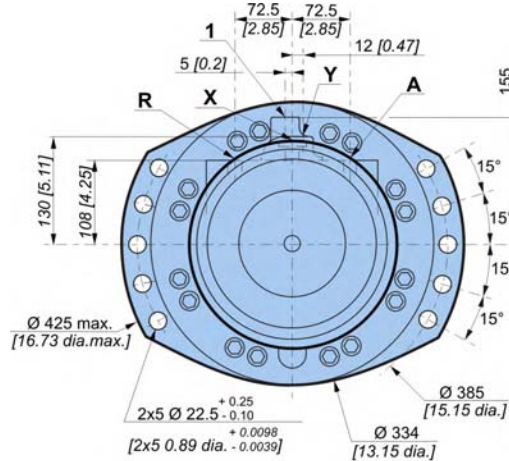

	112 kg [246 lb]	152 kg [334 lb]
	3.00 L [180 cu.in]	2.50 L [150 cu.in]



Also see 'Valving systems and hydrobases' section (thumbnail opposite).

	T12	T20
B	92.5 [3.64]	115 [4.53]
Ø C	273.6 [10.77]	282 [11.10]
D	24.5 [0.96]	45 [1.77]
E	128.5 [5.06]	128.5 [5.06]



Also see "Brake" section (thumbnail opposite).

- Modularity and Model code
- Wheel motor
- Shaft motor
- Valving systems and hydrobases
- Brake
- Options



**Support types**

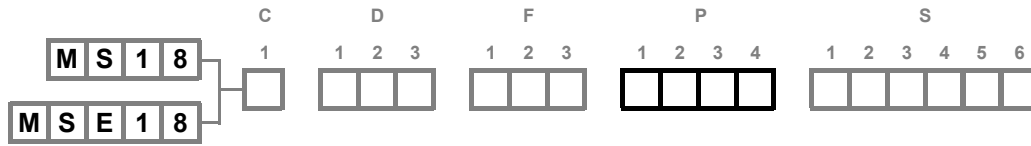

<b>C</b>		A	B	C	D	E	F	
<b>DIN 5480 splines</b>								
<b>2 A 5 0</b> 1 2 3 4 P	Nominal Ø	23	R 3	35	2 x M14	23	90	
	Module	[0.91]	[R 0.12]	[1.38]		[0.91]	[3.54]	
	Z							
<b>NF E22-141 splines</b>								
<b>2 A 1 0</b> 1 2 3 4 P	Nominal Ø	23	R 3	35	2 x M14	23	90	
	Module	[0.91]	[R 0.12]	[1.38]		[0.91]	[3.54]	
	Z							

Also see 'Valving systems and hydrobases' section (thumbnail opposite).

**Splined coupling**

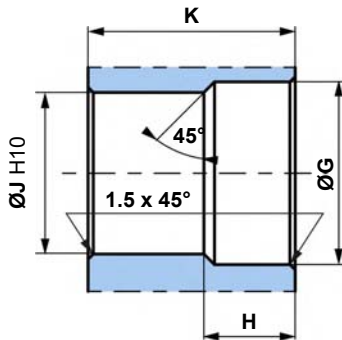

**Standard NF E22-141**

Pressure angle 20°.  
Centering on flanks.  
Slide fit (7H quality).

**Standard DIN 5480**

Pressure angle 30°.  
Centering on flanks.  
Slide fit (7H quality).

- N : Nominal Ø.
- Mo : Module.
- Z : Number of teeth.

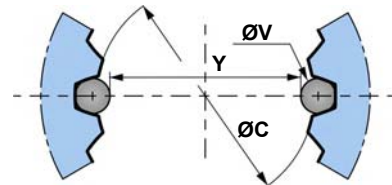

<b>C</b>		Ø G	H	Ø J	K	N	Mo	Z	Offset	Ø C (H10)	Ø V	Y	Tolerance µm [µin]
<b>2 A 1 0</b> 1 2 3 4 P		91	28	85	89	90	2.5	34	2	85	5	80.169	+ 104 / 0
		[3.58]	[1.10]	[3.35]	[3.50]	[3.54]			[0.08]	[3.35]	[0.20]	[3.16]	[+4.094 / 0]
<b>2 A 5 0</b> 1 2 3 4 P		91.5	25	84	89	90	3	28	1.35	84	5.25	79.110	+ 68 / 0
		[3.60]	[0.98]	[3.31]	[3.50]	[3.54]			[0.0531]	[3.31]	[0.21]	[3.11]	[+2.677 / 0]

General tolerances : ± 0.25 [±0.0098].

Material: Ex: 42CrMo4.

Hardening treatment to obtain R = 800 to 900 N/mm² [R = 116 030 to 130 533 PSI].





Load curves

**Permissible radial loads**

Max. permissible loads: 0 tr/min [0 RPM]; 0 bar [0 PSI]

Continuous permissible loads:  
 > 0 tr/min [> 0 RPM]; 275 bar [3 988 PSI].

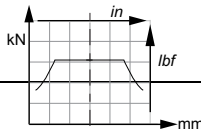

**Service life of bearings**

Test conditions :

L : Millions B10 revolutions at 150 bars (average pressure), with 25 cSt fluid, code 0 displacement, without axial load.

2	A	1	0
1	2	3	4

P

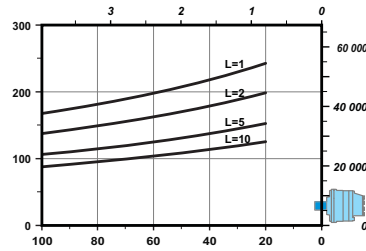
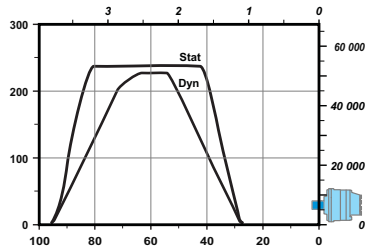

The service life of the components is influenced by the pressure. You must check that the combination of forces applied (Axial load / Radial load) is compatible with the permissible loads for the components, and that the resulting service lives of these components complies with the application's specifications. For an accurate calculation, consult your Poclain Hydraulics application engineer.

C			
2	A	1	0
2	A	5	0

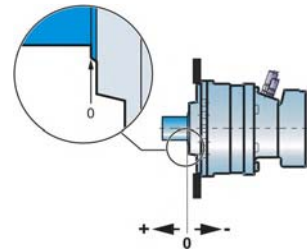

Modularity and Model code

Wheel motor

Shaft motor

Valving systems and hydrobases

Brake

Options





# VALVING SYSTEMS AND HYDROBASES

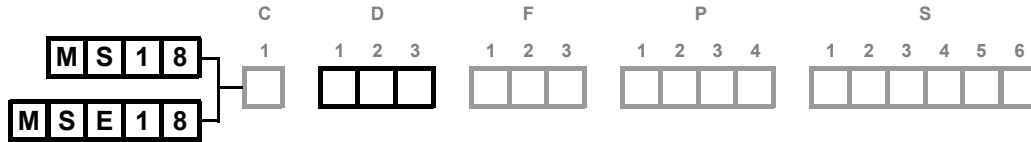

## Dimensions for 1-displacement valving

	68 kg [150 lb]	93 kg [205 lb]
	1.25 L [75 cu.in]	1.00 L [60 cu.in]

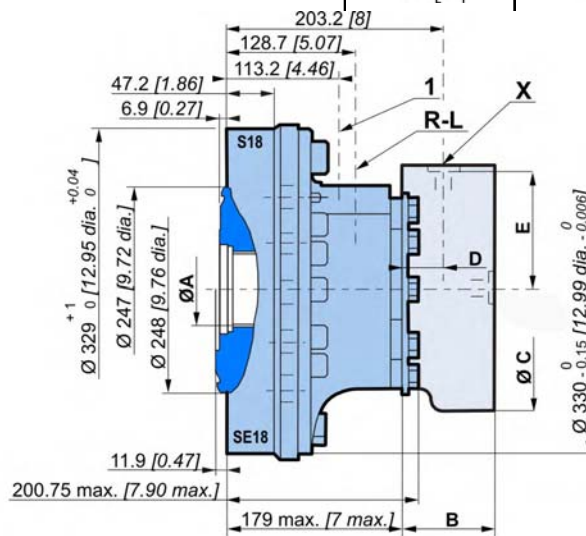
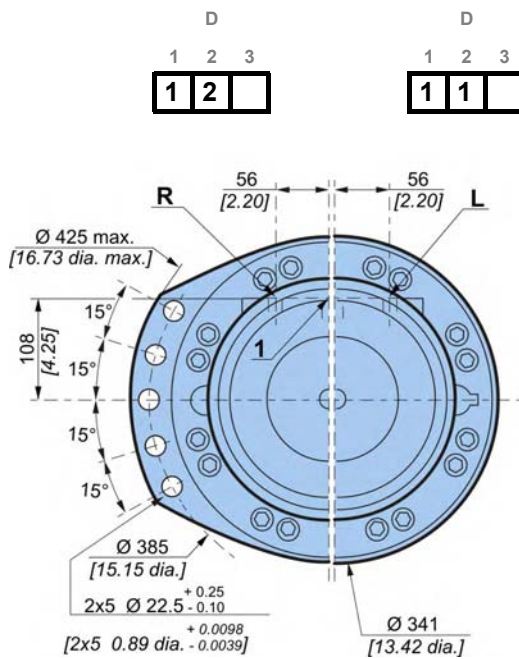

Modularity and Model code

Wheel motor

Shaft motor

Valving systems and hydrobases

Brake

Options

	T12	T20
<b>C</b>		
<b>B</b>	92.5 [3.64]	115 [4.53]
<b>Ø C</b>	273.6 [10.77]	282 [11.10]
<b>D</b>	24.5 [0.96]	45 [1.77]
<b>E</b>	128.5 [5.06]	128.5 [5.06]



Also see "Brake" section (thumbnail opposite).

## Cylinder block splines

(as per standard NF E22-141)

ØA	Module	Z	Dimension on 2 pins	
			Y	ØV
90 [3.543]	2.5	34	65.169 [3.156]	5 [0.197]

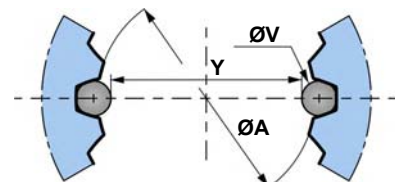

You are advised to have the installation validated by your Poclain Hydraulics application engineer before using the hydraulic unit in an application.



We must provide you with a detailed plan of the interface for any hydraulic unit use, consult your Poclain Hydraulics sales engineer.



**Dimensions for 2-displacement valving**

	78 kg [172 lb]	99 kg [218 lb]
	1.25 L [75 cu.in]	1.00 L [60 cu.in]

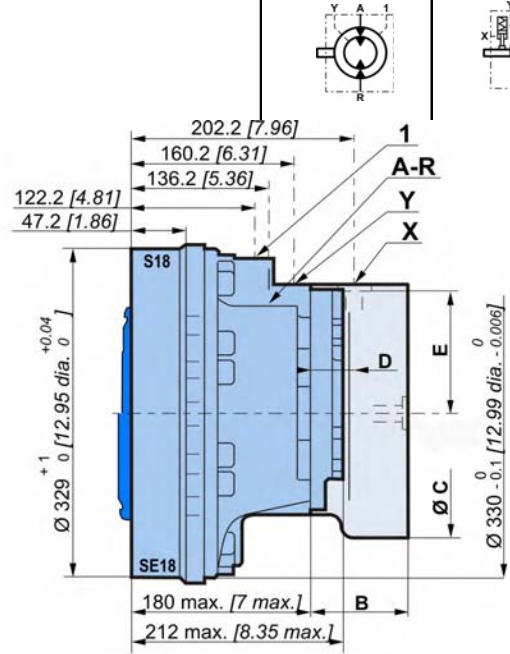
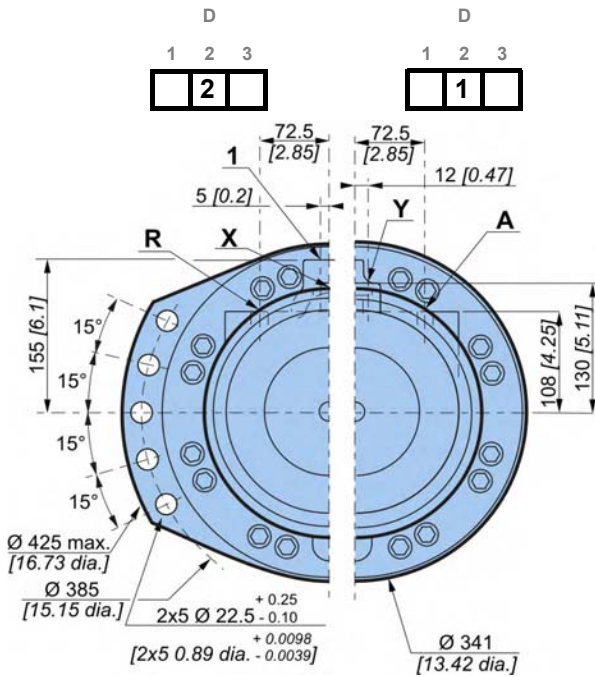

**Dimensions for Twin-Lock™ valving**

	78 kg [172 lb]	99 kg [218 lb]
	1.25 L [75 cu.in]	1.00 L [60 cu.in]

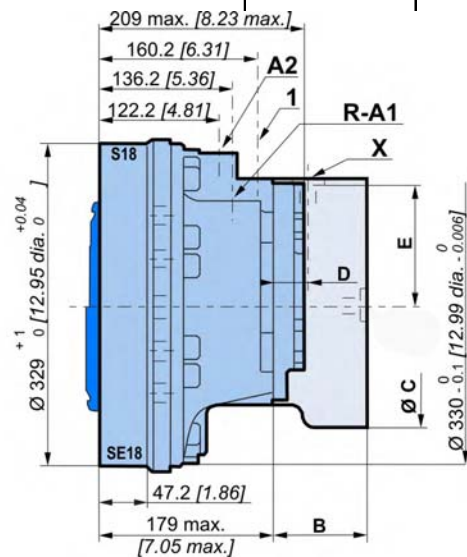
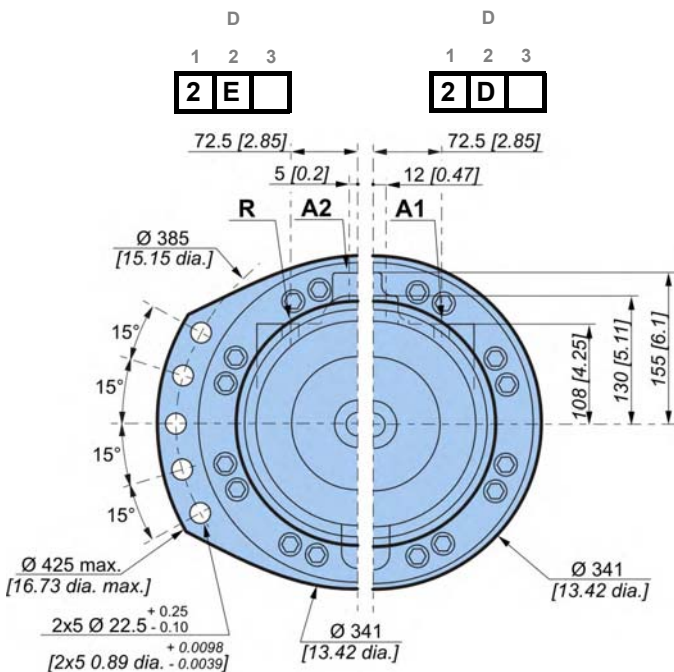

	T12	T20
C		
B	92.5 [3.64]	115 [4.53]
Ø C	273.6 [10.77]	282 [11.10]
D	24.5 [0.96]	45 [1.77]
E	128.5 [5.06]	128.5 [5.06]



Also see "Brake" section (thumb-nail opposite).



**Dimensions for 1-displacement valving with built-in exchange**

	68 kg [150 lb]	93 kg [205 lb]
	1.25 L [75 cu.in]	1.00 L [60 cu.in]

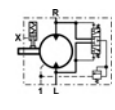
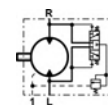
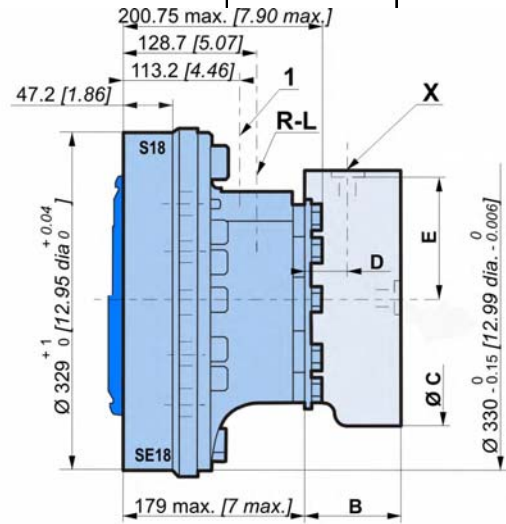
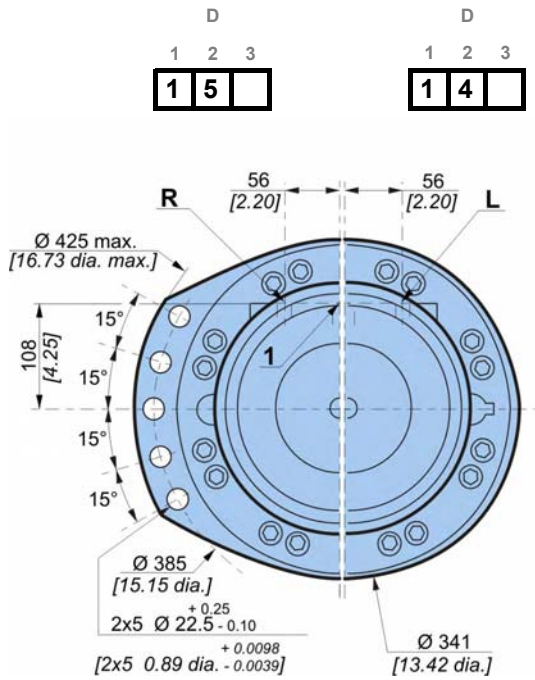

**Dimensions for 2-displacement symmetrical valving**

	78 kg [172 lb]	99 kg [218 lb]
	1.25 L [75 cu.in]	1.00 L [60 cu.in]

For a small displacement, there is no preferred orientation for this motor.

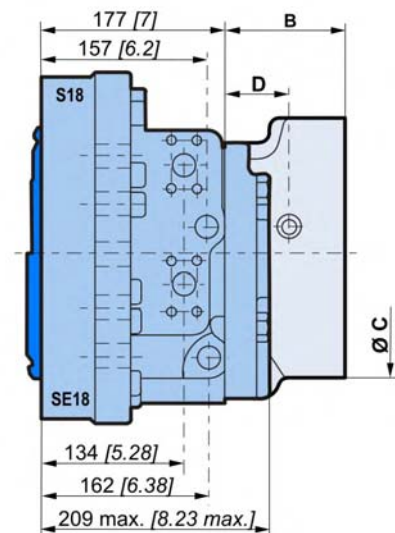
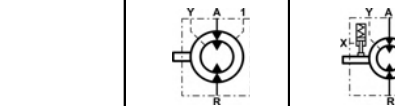
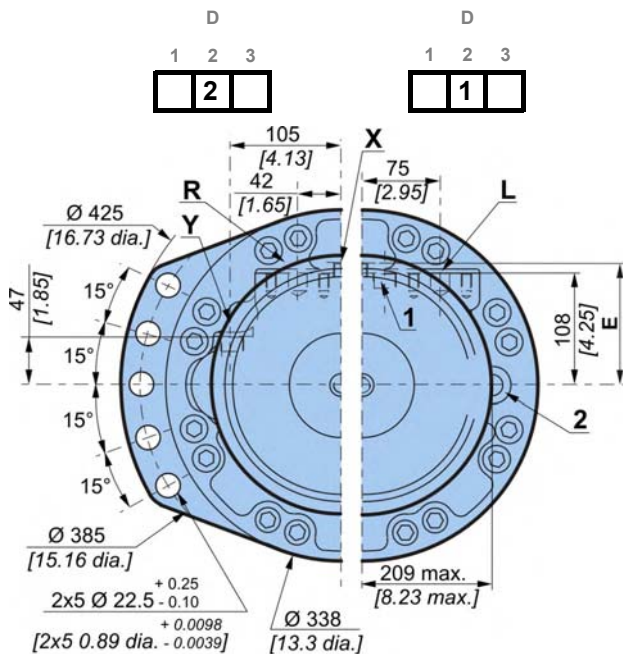

	T12	T20
<b>B</b>	92.5 [3.64]	115 [4.53]
<b>Ø C</b>	273.6 [10.77]	282 [11.10]
<b>D</b>	24.5 [0.96]	45 [1.77]
<b>E</b>	128.5 [5.06]	128.5 [5.06]



Also see "Brake" section (thumbnail opposite).

Modularity and Model code

Wheel motor

Shaft motor

Valving systems and hydrobases

Brake

Options





**Dimensions for Twin-Lock™ / 2-displacement valving**

	78 kg [172 lb]	99 kg [218 lb]
	1.25 L [75 cu.in]	1.00 L [60 cu.in]

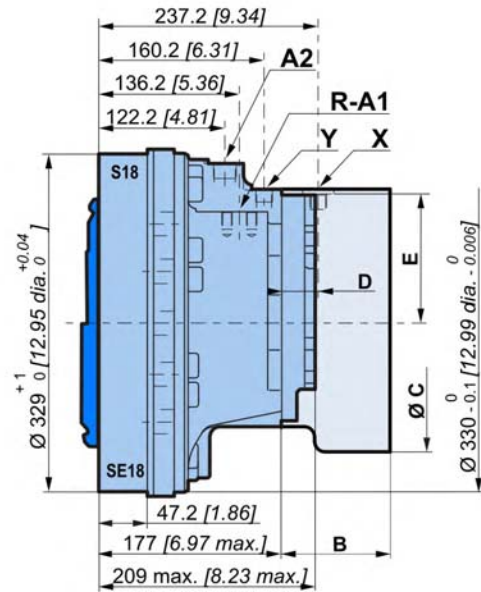
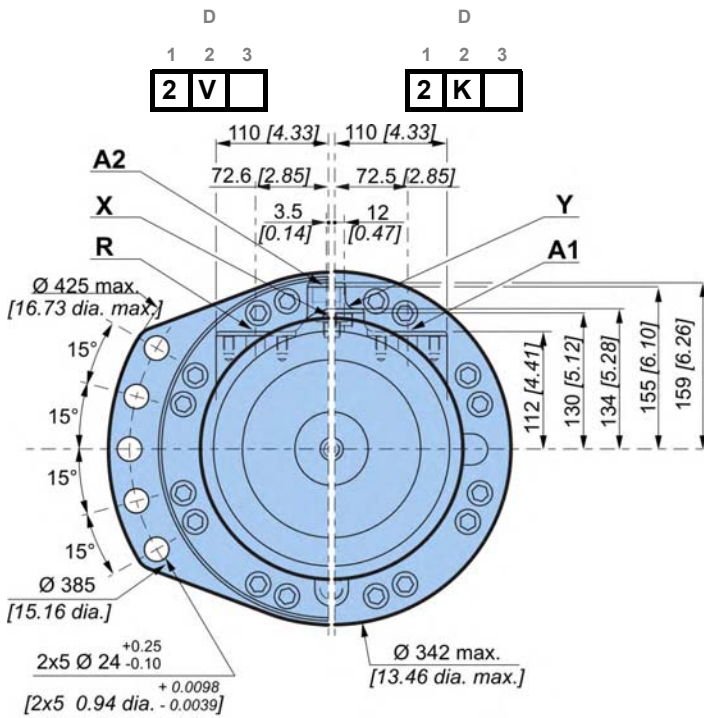

**Dimensions for 2-displacement / Twin-lock™ valving**

	78 kg [172 lb]	99 kg [218 lb]
	1.25 L [75 cu.in]	1.00 L [60 cu.in]

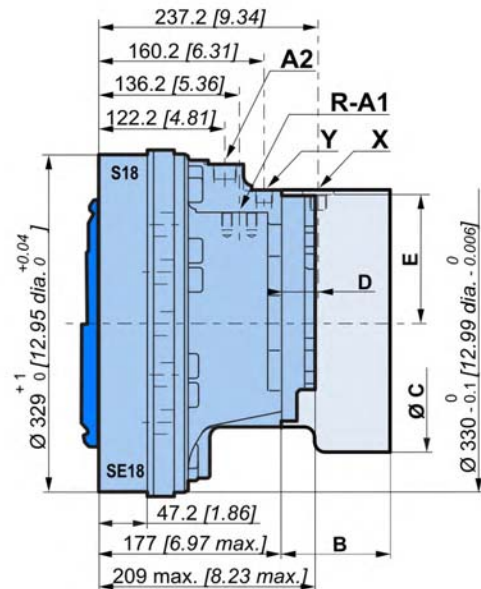
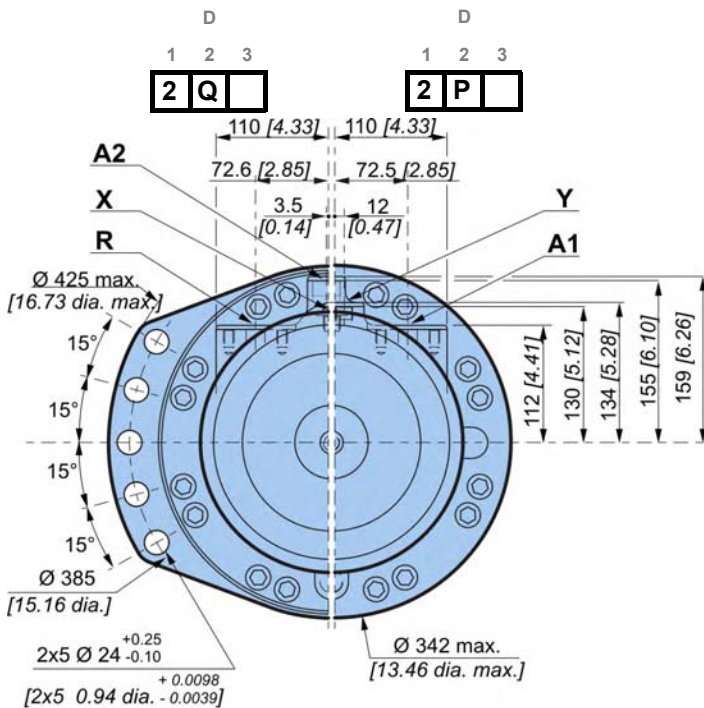

	T12	T20
B	92.5 [3.64]	115 [4.53]
Ø C	273.6 [10.77]	282 [11.10]
D	24.5 [0.96]	45 [1.77]
E	128.5 [5.06]	128.5 [5.06]



Also see "Brake" section (thumb-nail opposite).





Dimensions for Twin-Lock™ valving with by-pass

	78 kg [172 lb]	99 kg [218 lb]
	1.25 L [75 cu.in]	1.00 L [60 cu.in]

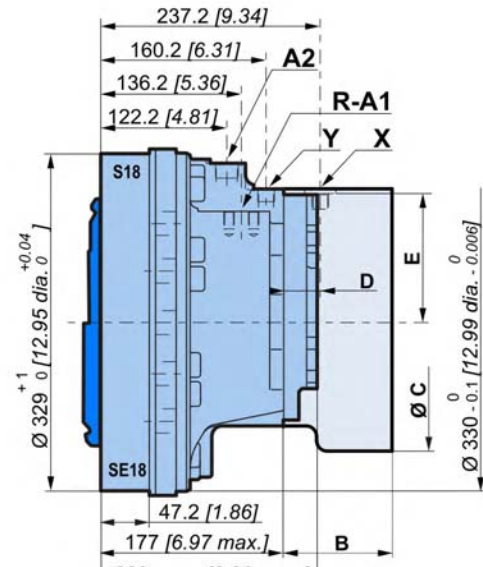
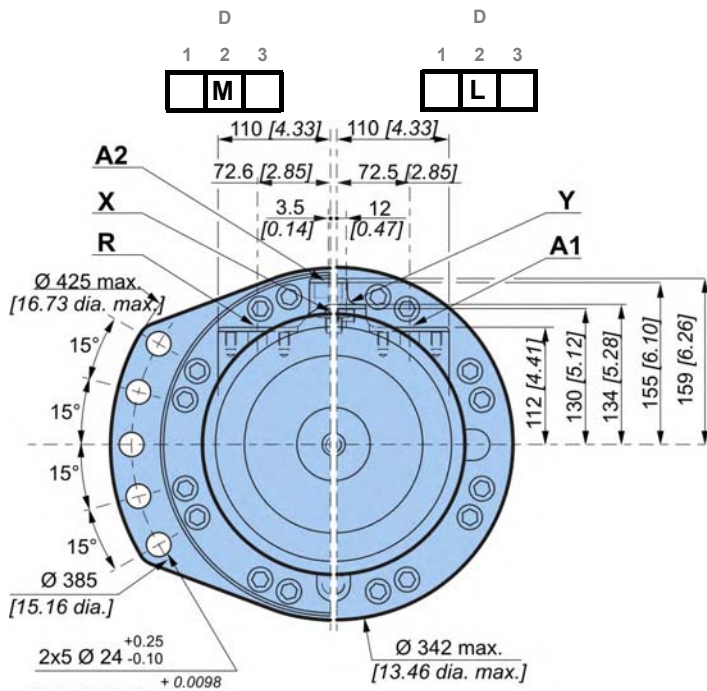

	T12	T20
B	92.5 [3.64]	115 [4.53]
Ø C	273.6 [10.77]	282 [11.10]
D	24.5 [0.96]	45 [1.77]
E	128.5 [5.06]	128.5 [5.06]



Also see "Brake" section (thumb-nail opposite).



We can obtain a more important flow and speed with this valving system. For an accurate calculation, consult your Poclain Hydraulics application engineer.

Modularity and Model code

Wheel motor

Shaft motor

Valving systems and hydrobases

Brake

Options



Dimensions for 1-displacement valving

91 kg [199 lb]  
2,00 L [120 cu.in]

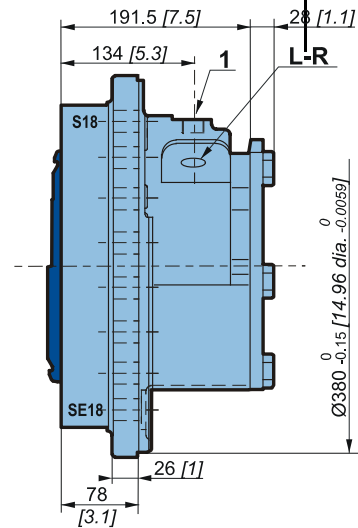
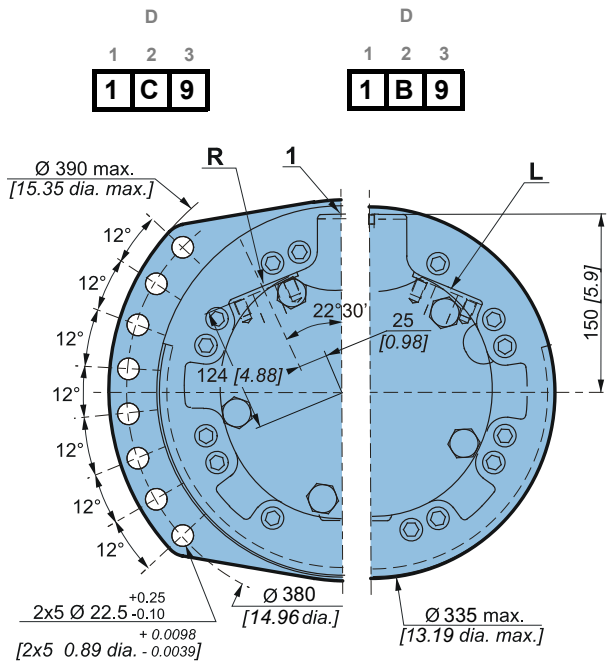

Dimensions for 2-displacement valving

91 kg [199 lb]  
2,00 L [120 cu.in]

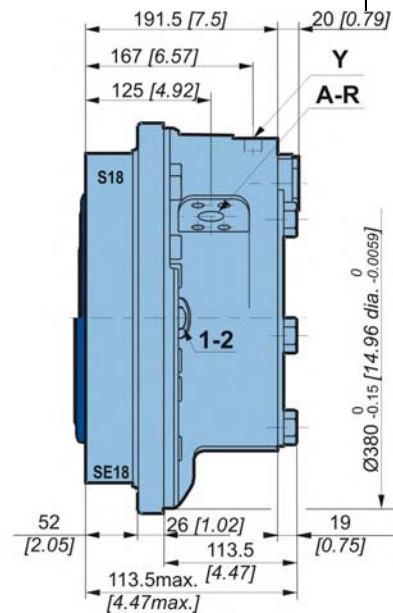
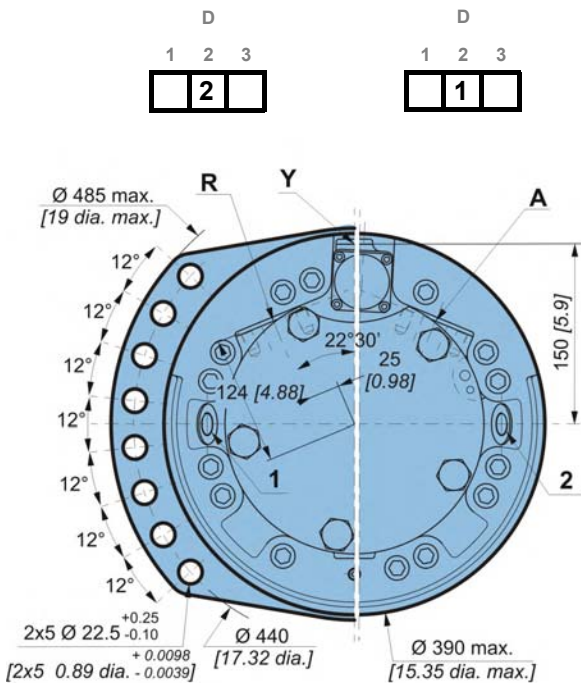



### Exchange

When a coding request is made, you must specify information on the threshold of the selector and the valve.

#### Selector spool

Selector threshold bar [PSI]	Opening pressure of selector bar [PSI]
8 [116]	9.9 ± 1.2 [144 ± 17]

#### Fitted valve

P1 bar [PSI]	Q2 L/min [GPM]	P2 bar [PSI]
13.5 [195]	14 [3.7]	16 [232]
18 [261]	15 [3.9]	21 [305]
22 [319]	16 [4.2]	25 [363]

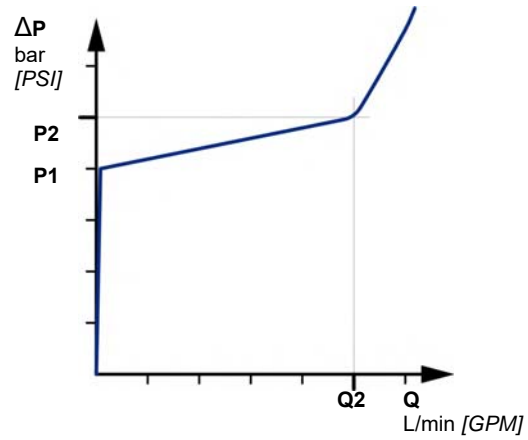

### Chassis mountings

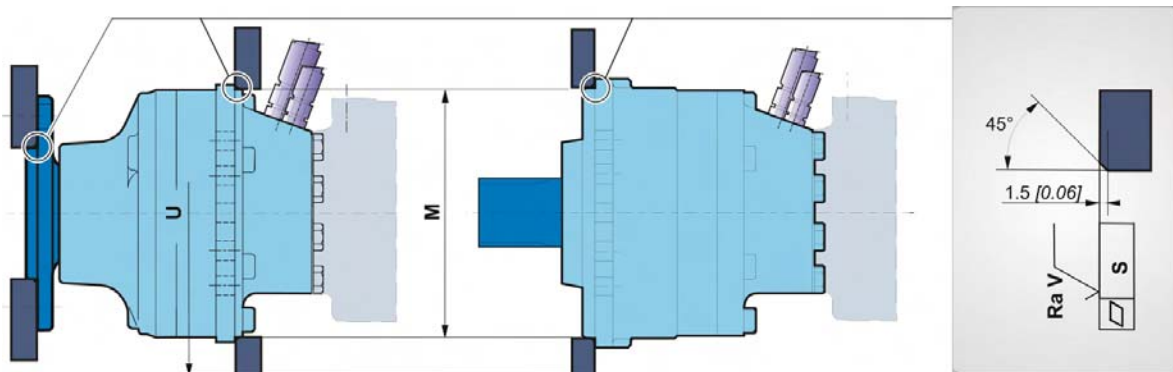

Take care over the immediate environment of the connections.

	ØM <sup>(1)</sup>	ØU	S	Ra V		Class
MS35	Wheel motor	330 [12.99]	385 [15.16]			
	Shaft motor	315 [12.40]	385 [15.16]		2 x 5 M20 x 2.5	
	Wheel motor FT30	380 [14.96]	440 [17.32]			4 x 3 M20 x 2.5
MS18 / MSE18	Wheel motor FT30	380 [14.96]	440 [17.32]	0.2 [0.008]	12.5 [0.492]	
	Wheel motor	330 [12.99]	385 [15.16]			2 x 5 M20 x 2.5
	Shaft motor					2 x 8 M20 x 2.5
	Short wheel motor	380 [14.96]	440 [17.32]			2 x 8 M20 x 2.5

(1) +0.3 [+0.012]  
+0.2 [+0.008]

Modularity and Model code

Wheel motor

Shaft motor

Valving systems and hydrobases

Brake

Options



Hydraulic connections

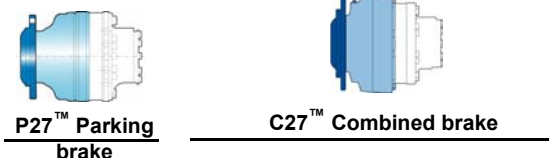
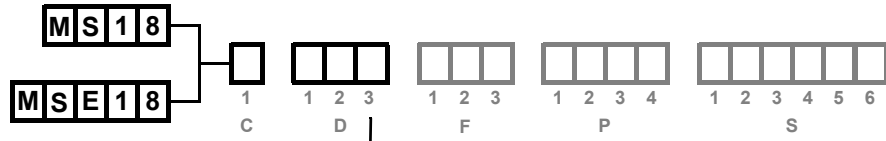

	Old standards	Standards	Power supply	Case drain	2 <sup>nd</sup> displacement control	Control of parking brake	Control of parking brake	Control of service brake	Flushing		
1 displacement			R-L	1, 2		X	X	XD	3		
	A	SAE J514	ISO 11926-1	1" 1/16"-12 UNF	7/8"-14 UNF		9/16"-18 UNF	9/18"-18 UNF	9/16"-18 UNF	3/4"-16 UNF	
	1	ISO 6162 DIN 3852	ISO 6162 ISO 9974-1	DN19 PN400	M 22x15		M 16x15	M 20x15	M 14x15	M 22x15	
	2	ISO 6162 BSP	ISO 6162 ISO 1179-1	DN19 PN400	Ø21 [1/2" dia.]		BSP 3/8	M 16x15	M 14x15	M 14x15	
	4	NF E48 050	ISO 9974-1	M 27x2	M 22x15		M 16x15	M 20x15	M 14x15	M 22x15	
	7	ISO 6162 SAE J514	ISO 6162 ISO 11926-1	DN19 PN400	7/8"-14 UNF		9/16"-18 UNF	9/16"-18 UNF	9/16"-18 UNF	3/4"-16 UNF	
					R-A	1, 2	Y	X	X	XD	3
	A	SAE J514	ISO 11926-1	1" 1/16"-12 UNF	7/8"-14 UNF	3/4"-16 UNF	9/16"-18 UNF	9/16"-18 UNF	9/16"-18 UNF	3/4"-16 UNF	
	1	ISO 6162 DIN 3852	ISO 6162 ISO 9974-1	DN19 PN400	M 22x15	M 16x15	M 16x15	M 20x15	M 14x15	M 22x15	
	1*	ISO 6162 DIN 3852	ISO 6162 ISO 9974-1	DN19 PN400	M 22x15	M 22x15	M 16x15	M 20x15	M 14x15	M 22x15	
4	NF E48 050	ISO 9974-1	M 27x2	M 22x15	M 16x15	M 16x15	M 20x15	M 14x15	M 22x15		
4*	NF E48 050	ISO 9974-1	M 27x2	M 22x15	M 22x15	M 16x15	M 20x15	M 14x15	M 22x15		
7	ISO 6162 SAE J514	ISO 6162 ISO 11926-1	DN19 PN400	7/8"-14 UNF	3/4"-16 UNF	9/16"-18 UNF	9/16"-18 UNF	9/16"-18 UNF	3/4"-16 UNF		
7*	ISO 6162 SAE J514	ISO 6162 ISO 11926-1	DN19 PN400	7/8"-14 UNF	7/8"-14 UNF	9/16"-18 UNF	9/16"-18 UNF	9/16"-18 UNF	3/4"-16 UNF		
Twin-Lock™			R-A 1	A 2	1, 2	Y	X	X	XD	3	
	A	SAE J514	ISO 11926-1	1" 1/16"-12 UNF	3/4"-16 UNF	9/16"-18 UNF	9/16"-18 UNF	9/16"-18 UNF	9/16"-18 UNF	3/4"-16 UNF	
	1	ISO 6162 DIN 3852	ISO 6162 ISO 9974-1	DN19 PN400	M 27x2	M 22x15	M 16x15	M 16x15	M 20x15	M 14x15	M 22x15
	7	ISO 6162 SAE J514	ISO 6162 ISO 11926-1	DN19 PN400	1" 1/16"-12 UNF	3/4"-16 UNF	9/16"-18 UNF	9/16"-18 UNF	9/16"-18 UNF	9/16"-18 UNF	3/4"-16 UNF
S 35			R-L	1, 2		X	X	XD	3		
	9	ISO 6162 DIN 3852	ISO 6162 ISO 9974-1	DN32 PN400	M 22x15		M 16x15	M 20x15	M 14x15	M 22x15	
			R-A	1, 2	Y	X	X	XD	3		
	1	ISO 6162 DIN 3852	ISO 6162 ISO 9974-1	DN25 PN400	M 22x15	M 18x15	M 16x15	M 20x15	M 14x15	M 22x15	
7	ISO 6162 SAE J514	ISO 6162 ISO 11926-1	DN25 PN400	1" 1/16"-12 UNF	9/16"-18 UNF	9/16"-18 UNF	9/16"-18 UNF	9/16"-18 UNF	3/4"-16 UNF		
Max. pressures	M S	bar	450 [6 527]	450 [6 527]	1 [15]	30 [435]	30 [435]	130 [1885]	70 [1015]	30 [435]	
	M S E	[PSI]	400 [5 802]	400 [5 802]							

\* : Only symmetrical valving



To find the connections' tightening torques, see the brochure "Installation guide" N° B61352L.



You are strongly advised to use the fluids specified in brochure "Installation guide" N° B61352L.

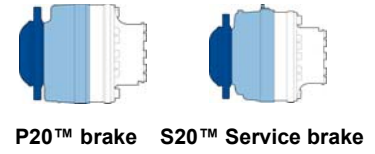
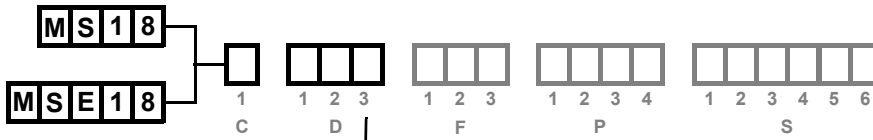

	Old standards	Standards	Power supply	Case drain	2 <sup>nd</sup> displacement control	Control of parking brake	Control of service brake	Flushing		
<b>S18</b>			R-L	1, 2	X	XD 1-XD 2	3			
<b>1 displacement</b>	<b>A</b>	SAE J514 <b>ISO 11926-1</b>	↑ 1/16"-12 UNF	7/8"-14 UNF		3/4"-16 UNF	9/16"-18 UNF	7/8"-14 UNF		
	<b>1</b>	ISO 6 162 DIN 3 852	<b>ISO 6 162</b> <b>ISO 9 974-1</b>	DN 19 PN400	M 22x15	M 16x15	M 14x15	M 22x15		
	<b>2</b>	ISO 6 162 BSP	<b>ISO 6 162</b> <b>ISO 1 179-1</b>	DN 19 PN400	Ø21 [1/2" dia.]	BSP 3/8	BSP 1/4	BSP 1/2		
	<b>4</b>	NF E48 050	<b>ISO 9 974-1</b>	M 27x2	M 22x15	M 16x15	M 14x15	M 22x15		
	<b>7</b>	ISO 6 162 SAE J514	<b>ISO 6 162</b> <b>ISO 11926-1</b>	DN 19 PN400	7/8"-14 UNF		3/4"-16 UNF	9/16"-18 UNF	7/8"-14 UNF	
<b>2 Displacement</b>	<b>A</b>	SAE J514 <b>ISO 11926-1</b>	↑ 1/16"-12 UNF	7/8"-14 UNF	3/4"-16 UNF	3/4"-16 UNF	9/16"-18 UNF	7/8"-14 UNF		
	<b>1</b>	ISO 6 162 DIN 3 852	<b>ISO 6 162</b> <b>ISO 9 974-1</b>	DN 19 PN400	M 22x15	M 16x15	M 16x15	M 14x15	M 22x15	
	<b>1*</b>	ISO 6 162 DIN 3 852	<b>ISO 6 162</b> <b>ISO 9 974-1</b>	DN 19 PN400	M 22x15	M 22x15	M 16x15	M 14x15	M 22x15	
	<b>4</b>	NF E48 050	<b>ISO 9 974-1</b>	M 27x2	M 22x15	M 16x15	M 16x15	M 14x15	M 22x15	
	<b>4*</b>	NF E48 050	<b>ISO 9 974-1</b>	M 27x2	M 22x15	M 22x15	M 16x15	M 14x15	M 22x15	
	<b>7</b>	ISO 6 162 SAE J514	<b>ISO 6 162</b> <b>ISO 11926-1</b>	DN 19 PN400	7/8"-14 UNF	3/4"-16 UNF	3/4"-16 UNF	9/16"-18 UNF	7/8"-14 UNF	
	<b>7*</b>	ISO 6 162 SAE J514	<b>ISO 6 162</b> <b>ISO 11926-1</b>	DN 19 PN400	7/8"-14 UNF	7/8"-14 UNF	3/4"-16 UNF	9/16"-18 UNF	7/8"-14 UNF	
<b>Twin-Lock™</b>	<b>A</b>	SAE J514 <b>ISO 11926-1</b>	↑ 1/16"-12 UNF	↑ 1/16"-12 UNF	3/4"-16 UNF 7/8"-14 UNF	9/16"-18 UNF 3/4"-16 UNF	3/4"-16 UNF	9/16"-18 UNF	7/8"-14 UNF	
	<b>1</b>	ISO 6 162 DIN 3 852	<b>ISO 6 162</b> <b>ISO 9 974-1</b>	DN 19 PN400	M 27x2	M 22x15	M 16x15	M 16x15	M 14x15	M 22x15
	<b>7</b>	ISO 6 162 SAE J514	<b>ISO 6 162</b> <b>ISO 11926-1</b>	DN 19 PN400	↑ 1/16"-12 UNF	3/4"-16 UNF	9/16"-18 UNF	3/4"-16 UNF	9/16"-18 UNF	7/8"-14 UNF
<b>S35</b>			R-L	1, 2	X	XD 1-XD 2	3			
<b>1C</b>	<b>9</b>	ISO 6 162 DIN 3 852	<b>ISO 6 162</b> <b>ISO 9 974-1</b>	DN 32 PN400	M 22x15	M 16x15	M 14x15	M 22x15		
	<b>2C</b>	ISO 6 162 DIN 3 852	<b>ISO 6 162</b> <b>ISO 9 974-1</b>	DN 25 PN400	M 22x15	M 18x15	M 16x15	M 14x15	M 22x15	
<b>2C</b>	<b>7</b>	ISO 6 162 SAE J514	<b>ISO 6 162</b> <b>ISO 11926-1</b>	DN 25 PN400	↑ 1/16"-12 UNF	9/16"-18 UNF	3/4"-16 UNF	9/16"-18 UNF	7/8"-14 UNF	
			<b>ISO 9 974-1</b>							
<b>Max. pressures</b>	<b>MS</b>	bar	450 [6 527]	450 [6 527]	1 [15]	30 [435]	130 [1885]	70 [1015]	1[14.5]	
	<b>MSE</b>	[PSI]	400 [5 802]	400 [5 802]						

Modularity and Model code  
Wheel motor  
Shaft motor  
Valving systems and hydrobases  
Brake  
Options



To find the connections' tightening torques, see the brochure "Installation guide" N° B61352L.



You are strongly advised to use the fluids specified in brochure "Installation guide" N° B61352L.



Do not put either a check valve or a poppet valve on the pilot lines (parking brake and displacement change) between the charge pump and the pilot valve. Do not use a piloting valve with integrated check valve.





### Efficiency

#### Overall efficiency

Average values given for guidance for code 0 displacement after 100 hours of operation with HV46 hydraulic fluid at 50°C [122°F].

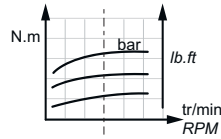
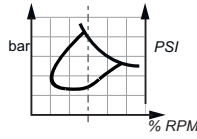

#### Actual output torque

MS18

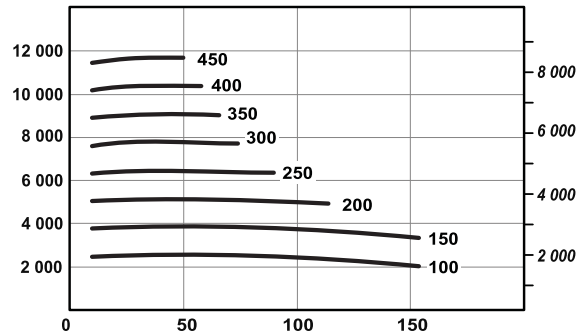
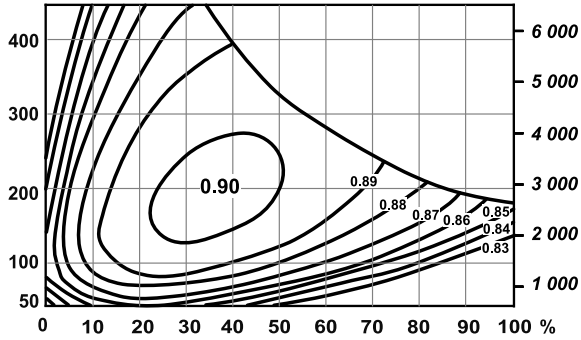

MSE18

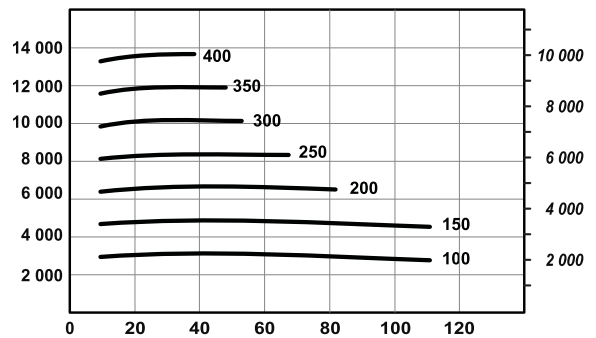
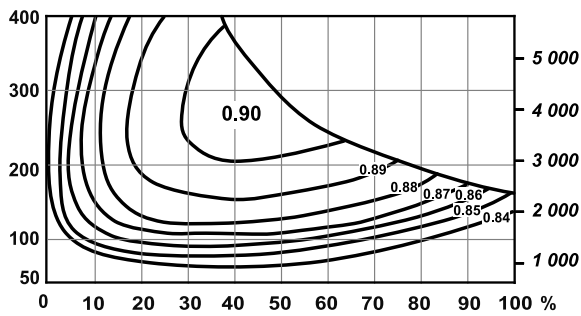

For a precise calculation, consult your Poclain Hydraulics application engineer.



# BRAKES

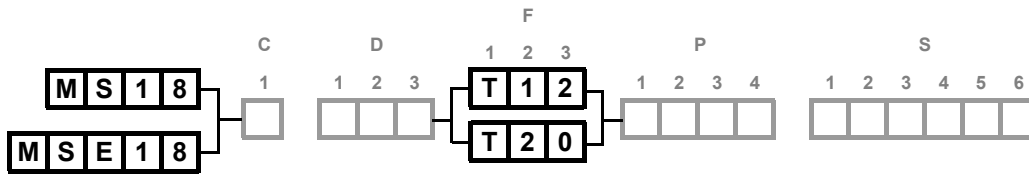

## Rear brake

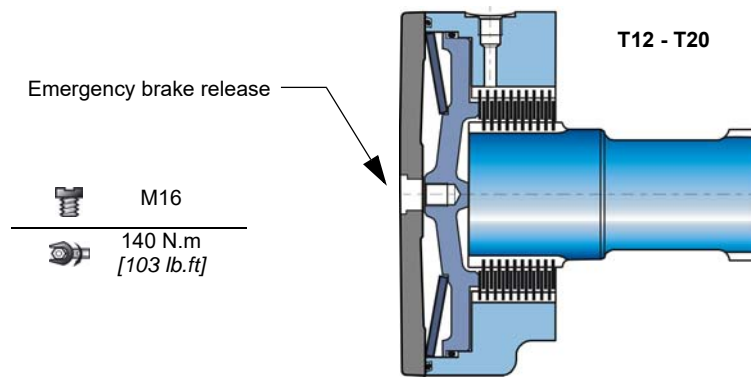

## Brake principle

This is a multidisc brake which is activated by a lack of pressure. The spring exerts a force on the piston, which presses on the fixed and mobile discs, and immobilizes the shaft. The braking torque decreases in linear proportion to the brake release pressure.

C	T 1 2	T 2 0
Parking brake torque at 0 bars on housing (new brake)	11,840 Nm [8,730 lb.ft]	19,000 Nm [14,010 lb.ft]
Min. dynamic brake torque in case of emergency brake with new brake	7,695 Nm [5,680 lb.ft]	12,350 Nm [9,110 lb.ft]
Residual parking braking at 0 bars on housing *	8,880 Nm [6,550 lb.ft]	14,250 Nm [10,510 lb.ft]
Min. brake release pressure	12 bar [174 PSI]	14 bar [203 PSI]
Max. brake release pressure	30 bar [435 PSI]	30 bar [435 PSI]
Oil capacity	170 cm <sup>3</sup> [10.4 cu.in]	180 cm <sup>3</sup> [11.0 cu.in]
Volume for brake release	40 cm <sup>3</sup> [2.4 cu.in]	70 cm <sup>3</sup> [4.3 cu.in]
Max. energy dissipation	123 699 J	193 033 J

\* After emergency brake has been used



**Do not run-in the multidisc brakes.**



**A functional check of the parking brake must be carried out each time it is used as an auxiliary brake (or emergency brake). For all vehicles capable of speeds over 25 km/h, please contact your Poclair Hydraulics application engineer.**



**The use of certain oils may not offer the characteristics stated above. Consult your Poclair Hydraulics application engineer.**

Modularity and Model code

Wheel motor

Shaft motor

Valving systems and hydrobases

Brake

Options



**C27™ Combined brake**

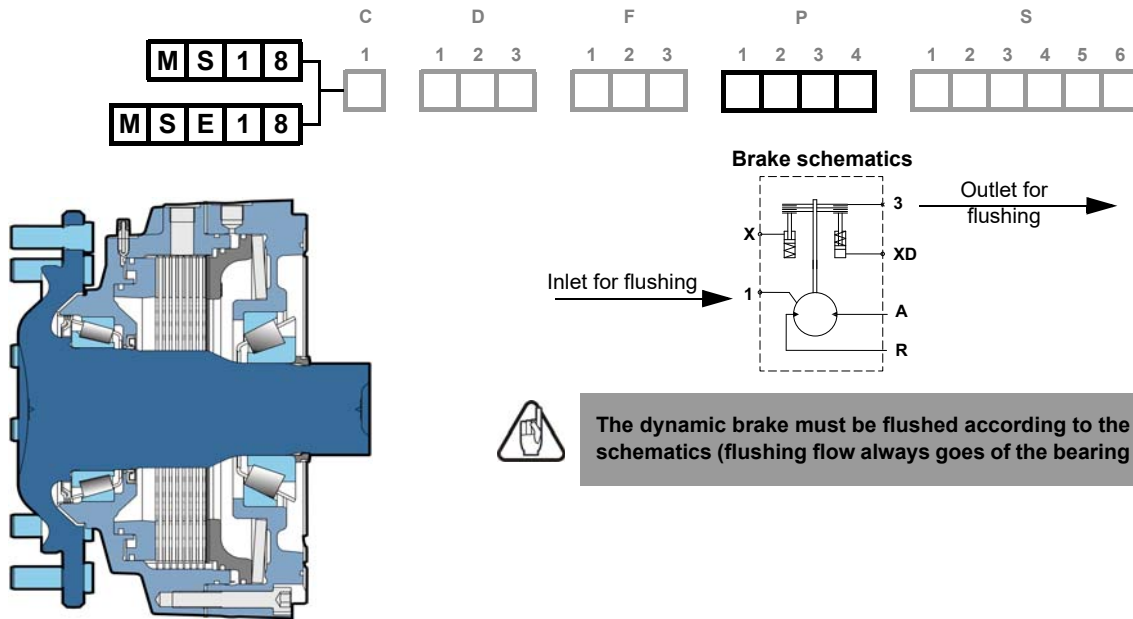

The dynamic brake must be flushed according to the brake schematics (flushing flow always goes of the bearing support).

**Brake principle**

This multi-disc brake operates in two distinct ways:  
 Either by an absence of pressure (static braking): The spring applies a force to the static piston that is transmitted to the dynamic piston, which damps the fixed and free discs, preventing the shaft from turning.  
 Or by braking pressure (dynamic braking): The braking command creates a pressure on the dynamic braking piston, which damps the fixed and free discs, preventing the shaft from turning. Braking torque increases linearly as a function of the piloting pressure.

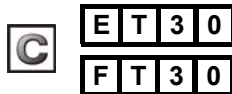

**General information**

Max. rotation speed	200 rpm
Max. energy dissipation for 1 braking (maintenance needed)	1000 kJ

**Dynamic brake information**

Permissible torque during dynamic braking	32 000 Nm [23 600 lb.ft]
Pressure to obtain max. permissible braking	70 bar [1 015 PSI]
Piston chamber piloting volume, worn brake	74 cm³ [4,5 cu.in]
Service brake max. allowed energy	500 kJ

**Parking brake information**

Min. parking brake torque	18 000 Nm [13 280 lb.ft]
Min. dynamic brake torque in case of emergency brake with new brake	24 000 Nm [17 700 lb.ft]
Min. dynamic brake torque in case of emergency brake with worn brake	13 000 Nm [9 590 lb.ft]
Release brake pressure (min. / max.)	100 [1 450] / 135 [1 958]
Piston chamber piloting volume (worn brake)	48 cm³ [2,9 cu.in]
Number of parking brake applications	1 000 000

**Flushing flow vs Rotation speed**

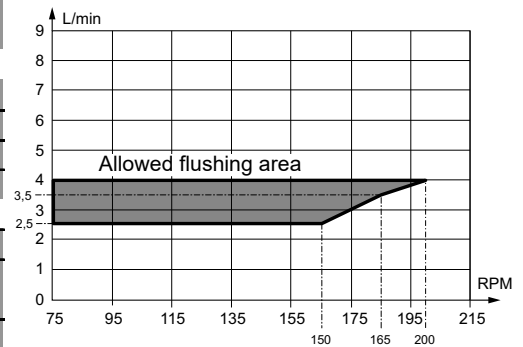

Brake release pressure vented.



The use of certain oils may not offer the characteristics stated above. Consult your Poclair Hydraulics application engineer.



When using the Boosted brake™ option, the C27™ bearing support might not be able to withstand the combination of maximum hydrostatic torque and maximum service brake torque. Please contact your Poclair Hydraulics application engineer for a detailed calculation.



**P27™ Parking brake**

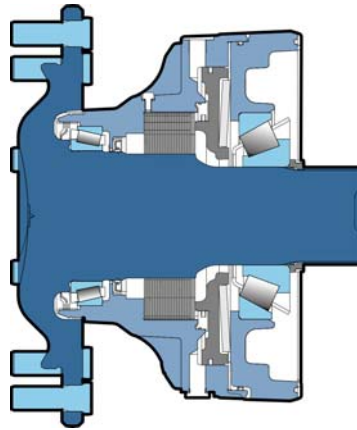
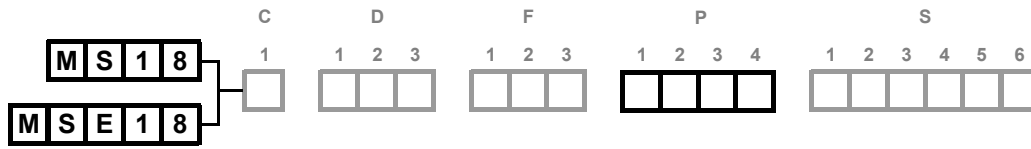

Brake schematic

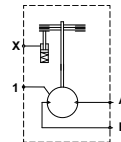

**Brake operation Brake principle**

This is a multidisc brake which is activated by a lack of pressure. The spring exerts a force on the piston, which presses on the fixed and mobile discs, and immobilizes the shaft. The braking torque decreases in linear proportion to the brake release pressure.

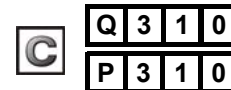

Max. rotation speed	200 rpm
Max. energy dissipation	200 kJ
Number of parking brake applications	1,000,000
Release brake pressure (min/max)	16 [232] / 30 [435]
Min. parking brake torque	19,800 Nm [14,600 lb.ft]
Min. static brake torque (after emergency braking)	16,400 Nm [12,100 lb.ft]
Min. dynamic brake torque in case of emergency brake with new brake	14,500 Nm [10,690 lb.ft]

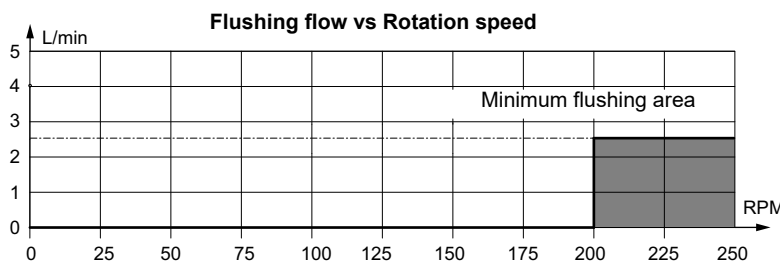

Do not run-in the multidisc brakes.



The use of certain oils may not offer the characteristics stated above. Consult your Poclain Hydraulics application engineer.



A functional check of the parking brake must be carried out each time it is used as an auxiliary brake (or emergency brake). For all vehicles capable of speeds over 25 km/h, please contact your Poclain Hydraulics application engineer.



When using the Boosted brake™ option, the P27™ bearing support might not be able to withstand the combination of maximum hydrostatic torque and maximum service brake torque. Please contact your Poclain Hydraulics application engineer for a detailed calculation.

Modularity and Model code

Wheel motor

Shaft motor

Valving systems and hydrobases

Brake

Options



**P20™ Parking brake**

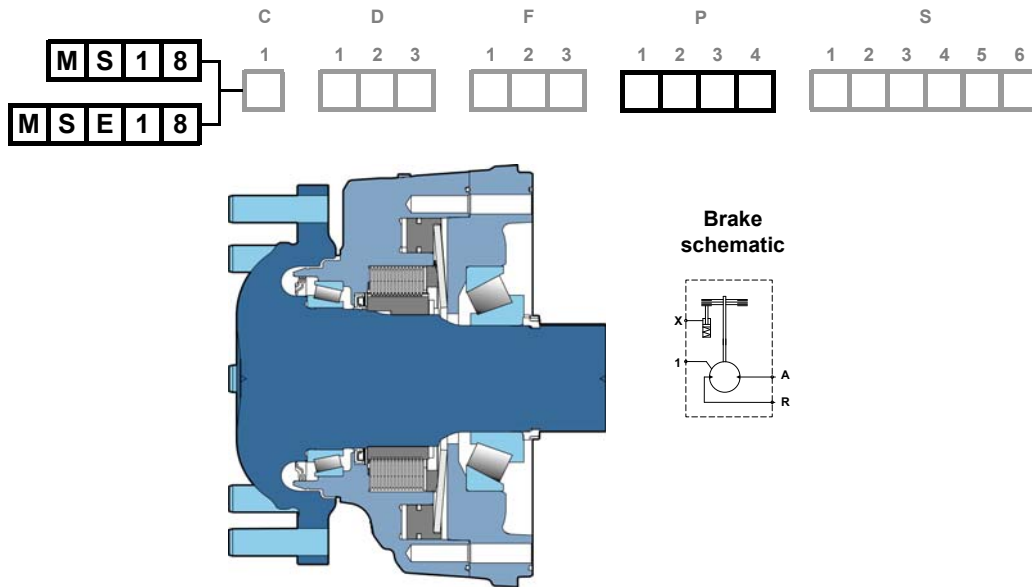

**Brake principle**

This is a multidisc brake which is activated by a lack of pressure. The spring exerts a force on the piston, which presses on the fixed and mobile discs, and immobilizes the shaft. The braking torque decreases in linear proportion to the brake release pressure.

	<b>C</b>	<b>R 2 1 0</b>
		<b>S 2 1 0</b>
Max. rotation speed	200 rpm	
Max. energy dissipation	200 kJ	
Number of parking brake applications	1 000 000	
Release brake pressure (min/max)	16 bar [232 PSI] / 30 bar [435 PSI]	
Min. parking brake torque	20 000 Nm [14 750 lb.ft]	
Min. static brake torque (after emergency braking)	15 000 Nm [11 060 lb.ft]	
Min. dynamic brake torque in case of emergency braking with new brake	13 000 Nm [9 590 lb.ft]	



**Do not run-in the multidisc brakes.**



**The use of certain oils may not offer the characteristics stated above. Consult your Poclain Hydraulics application engineer.**



**A functional check of the parking brake must be carried out each time it is used as an auxiliary brake (or emergency brake). For all vehicles capable of speeds over 25 km/h, please contact your Poclain Hydraulics application engineer.**



**When using the Boosted brake™ option, the P20™ bearing support might not be able to withstand the combination of maximum hydrostatic torque and maximum service brake torque. Please contact your Poclain Hydraulics application engineer for a detailed calculation.**





**S20™ Service brake**

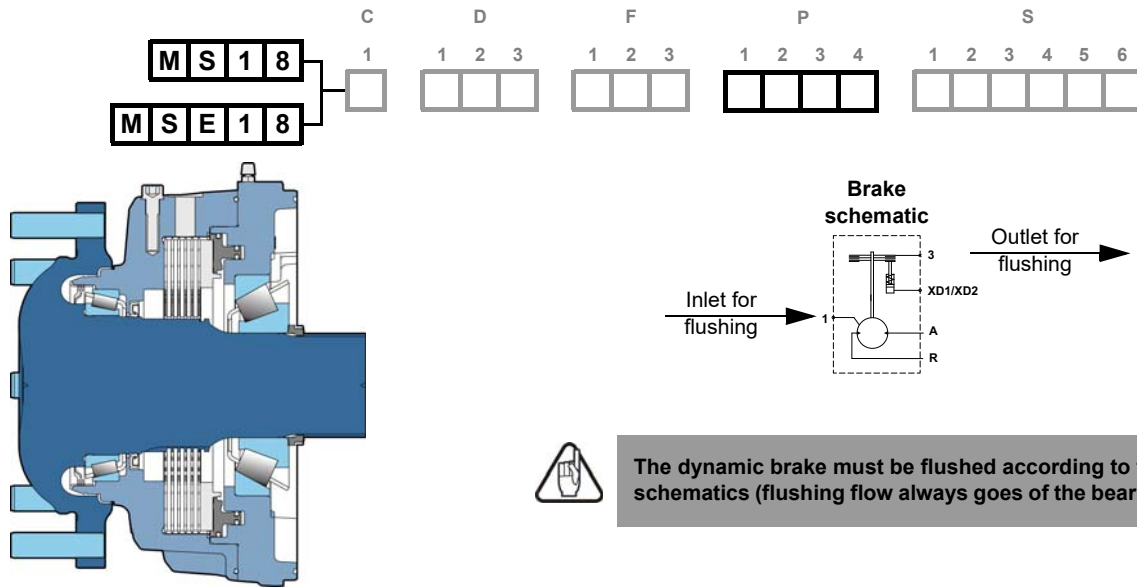

The dynamic brake must be flushed according to the brake schematics (flushing flow always goes of the bearing support).

**Brake principle**

This is a multidisc brake which is activated by a braking pressure (dynamic braking). The braking command creates a pressure on the dynamic braking piston, which damps the fixed and free discs, preventing the shaft from turning. Braking torque increases linearly as a function of the piloting pressure.

C	U 2 1 0	W 2 1 0
	V 2 1 0	Y 2 1 0

Max. rotation speed	200 rpm
Max. energy dissipation	1 250 kJ
Average torque during dynamic braking	25 000 Nm [18 440 lb.ft]
Pressure to obtain max. permissible braking	120 bar
Piston chamber piloting volume, worn brake	97 cm³
Service brake max. allowed energy	850 kJ

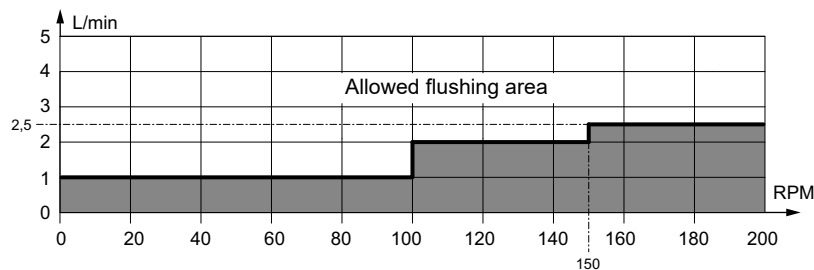

Do not run-in the multidisc brakes.



The use of certain oils may not offer the characteristics stated above. Consult your Poclair Hydraulics application engineer.



A functional check of the parking brake must be carried out each time it is used as an auxiliary brake (or emergency brake). For all vehicles capable of speeds over 25 km/h, please contact your Poclair Hydraulics application engineer.



When using the Boosted brake™ option, the S20™ bearing support might not be able to withstand the combination of maximum hydrostatic torque and maximum service brake torque. Please contact your Poclair Hydraulics application engineer for a detailed calculation.

Modularity and Model code

Wheel motor

Shaft motor

Valving systems and hydrobases

Brake

Options





# OPTIONS

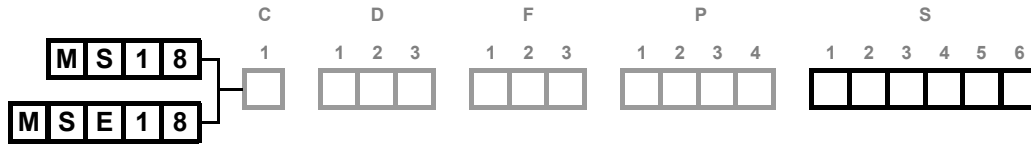

You can accumulate more than one optional part. Consult your Poclain Hydraulics sales engineer.

## 1 - Fluorinated elastomer seals

Nitrile seals marked in the figure below replaced by fluorinated elastomer seals.

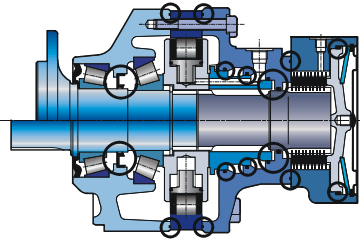

Consult your Poclain Hydraulics sales engineer.

## 2 - S - Q - 8 - Installed speed sensor or predisposition

### Designation

T4 speed sensor (without rotation direction)	2
TR speed sensor (digital rotation direction)	S
TD speed sensor (two phase shifted frequencies)	Q
Predisposition for speed sensor	8

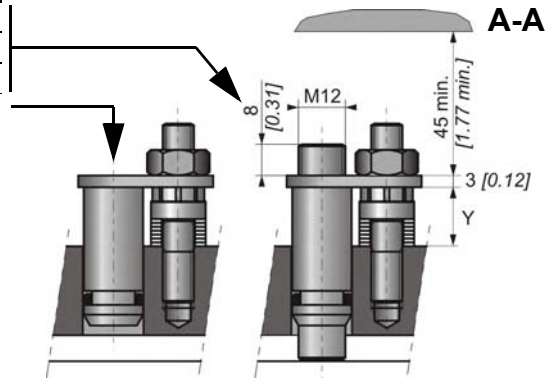
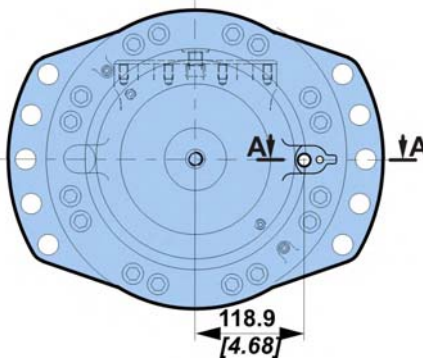

Max. length Y= 17.6

Standard number of pulses per revolution= 60



Look at the "Mobile Electronic" N° A01889D technical catalogue for the sensor specifications and its connection.



To install the sensor, see the "Installation guide" brochure No. B61352L.

Modularity and Model code

Wheel motor

Shaft motor

Valving systems and hydrobases

Brake

Options



### 3 - Brake environmental cover without plug

No plug or hole in the cover.

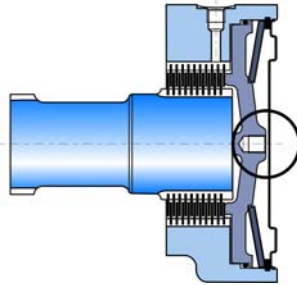

### 5 - Drainage

Additional drain in the cover.

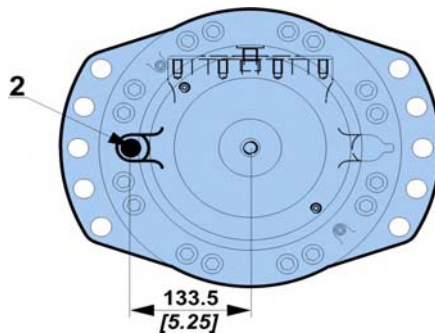

### 6 - Industrial support

Reduction of around 50% from the rated value in the bearings' preload value.



For a precise calculation, consult your Poclain Hydraulics application engineer.

### 7 - Diamond™

Special treatment of the motor core which considerably increases its strength, making the motor much more tolerant to temporary instances of the operating conditions being exceeded.

### A - Hollow shaft

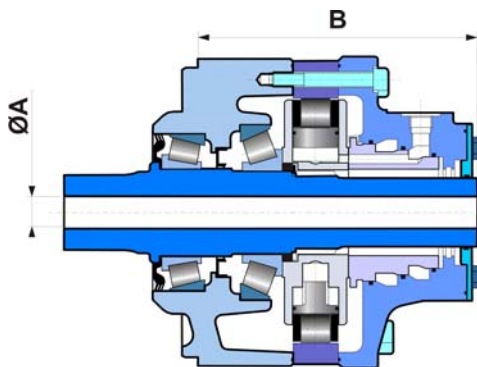

A	B
mm [in]	mm [in]
Ø 60 [2.36 dia.]	297.5 [11.71]

Radial load x 0.75  
No torque transmittable to the rear



**B - Drain on the bearing support**

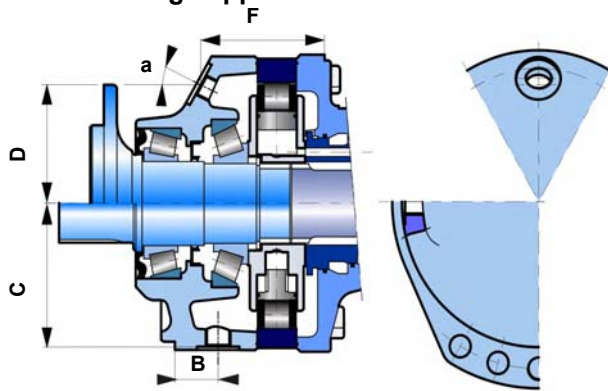

		B	C	D	F	a
		mm [in]	mm [in]	mm [in]	mm [in]	
Shaft motor	M16 x 1.5	34.0 [1.34]	100 [3.94]			
Wheel motor	M22 x 1.5			130.5 [5.14]	135 [5.31]	36°
Short wheel motor				123 [4.84]	121 [4.76]	25°

**C - Abrasive environments (mechanical seal)**

Some environments can be very harmful. The mirror seal gives reinforced motor sealing.

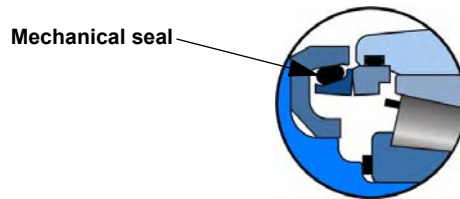

Consult your Poclair Hydraulics sales engineer.

**E - Reinforced sealing**

Requires reinforced seals and, for an unbraked motor, a rear reinforced plate (R18 - 8 [0.314] thick, instead of 4 [0.157]).

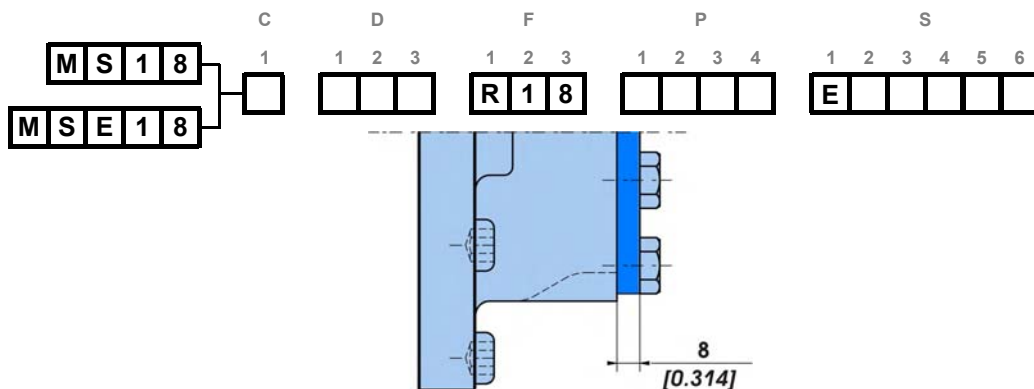

**G - Special wheel rim mounting**

Enables certain combinations different from the standard mountings defined on pages 10.



Consult your Poclair Hydraulics sales engineer.

Modularity and Model code

Wheel motor

Shaft motor

Valving systems and hydrobases

Brake

Options





### H - High efficiency

Reinforced piston sealing to improve volumetric efficiency.



For a precise calculation, consult your Poclain Hydraulics application engineer.

### J - Treated shaft

Heat treatment on the indicated bearing radius and splines.

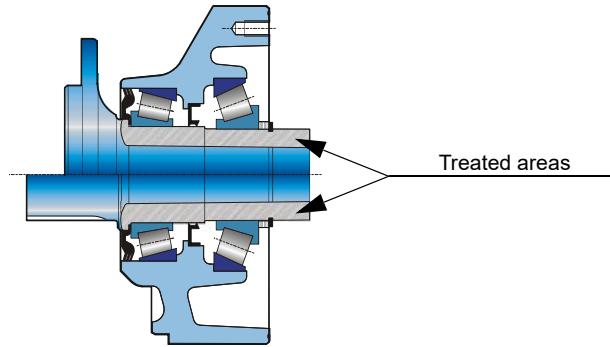

### M - High speed

Under certain conditions, an increase in the maximum speed of 30% above the values indicated in the table on page 2 is possible.



For a precise calculation, consult your Poclain Hydraulics application engineer.

### T - Soft Shift™

Progressive displacement change (cushioned slide-valve).

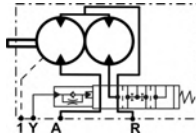

Consult your Poclain Hydraulics sales engineer.

### U - Boosted braking™



For a precise calculation, consult your Poclain Hydraulics application engineer.



Modularity and Model code

Wheel motor

Shaft motor

Valving systems and hydrobases

Brake

Options



*Poclain Hydraulics reserves the right to make any modifications it deems necessary to the products described in this document without prior notification. The information contained in this document must be confirmed by Poclain Hydraulics before any order is submitted.*

*Illustrations are not binding.*

*The Poclain Hydraulics brand is the property of Poclain Hydraulics S.A.*

-  14/02/2024
-  801 478 121D
-  801 478 191E
-  801 578 104F
-  801 578 116T
-  801 578 128G
-  A07444R
-  Non available
-  A14243G

