

Masoneilan™ 21000 Series

Top Guided Globe Valves
with Lo-dB, Anti-Cavitation,
Bellows and API 6A High
Pressure Capabilities

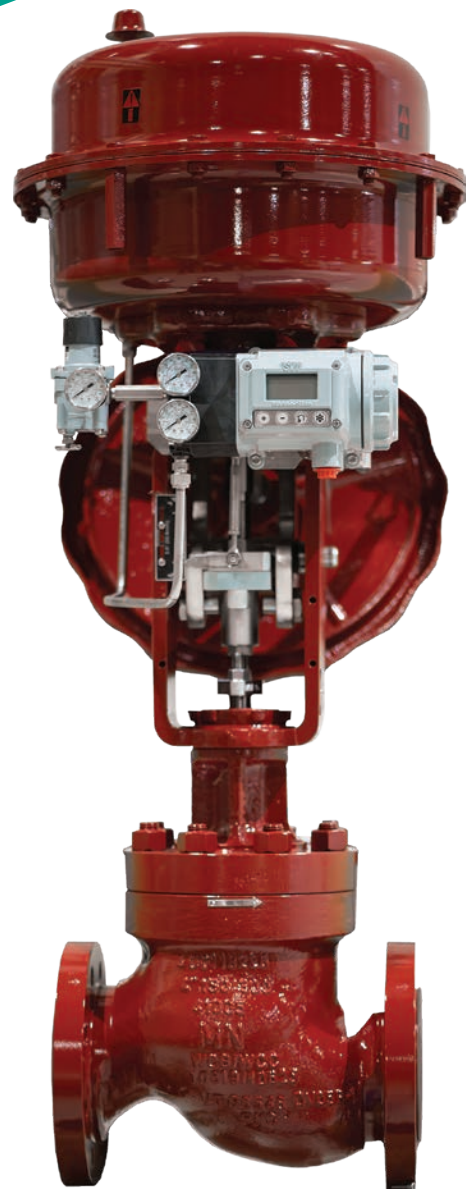
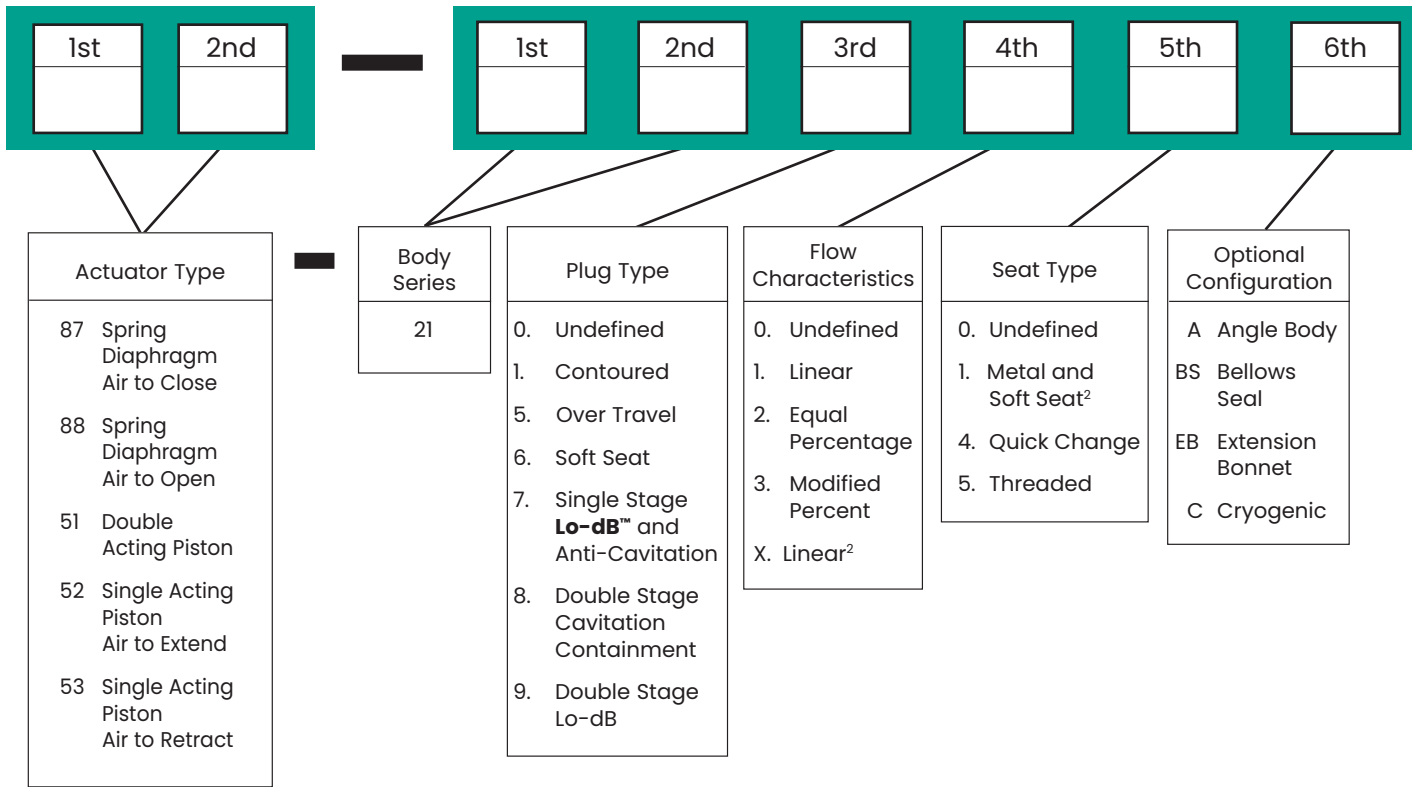

Table of Contents

Numbering System	3
Temperature Range and Seat Leakage	4
Ratings and Connections 1.....	5
C_v and F_L Versus Travel	6
Contoured Trim.....	6-9
Contoured Plug.....	10-19
Contoured Trim.....	20
C_v and F_L Versus Travel	21
Single Stage Lo-dB and Anti-Cavitation Trim Single Stage Cavitation Containment.....	21-23
Double Stage Anti-Cavitation Trim	24
Double Stage Lo-dB Trim.....	25
21000 Series Standard Design – Materials of Construction	26
Carbon Steel Version.....	27
Stainless Steel Version.....	28
Chrome Moly Version.....	29
NACE Materials Construction.....	30
Cryogenic Construction	31
21000 BS Series Bellows Seal Design	32
Size and ratings.....	32
21000 BS Series Bonnet-less Design – Materials of Construction	33
Carbon Steel Body Version.....	34
Stainless Steel Body Version.....	35
21000 BS Series Bonnet Design – Materials of Construction	36
Carbon Steel Body Version	37
Stainless Steel Body Version	38
Dimensions (inches)	39-40
Dimensions (mm)	41-42
Weights	43
API 6A 21000 Series – High Pressure Design	44
Size and ratings.....	44
API 6A 21000 Series C_v and F_L Versus Travel	45
API 10K and 15K – FTO and FTC Models 21114.....	45
API 6A 21000 Series – Materials of Construction	47-52
Duplex F51 Stainless-Steel Construction.....	49
Super Duplex F55 Stainless-Steel Construction	50
CRA Nickel-Alloy Inconel 718 Construction.....	51
Common Parts.....	52
API 6A 21000 Series – Dimensions and Weights	53-54
API 10K and 15K Body S/A (mm).....	54
API 10K and 15K Body S/A (in.)	54

Numbering System



Notes:

1. Configuration for 21000 API 6A. See more details on page 27.
For high temperature application, consult Engineering.

2. Over Travel Plug only.

Temperature Range and Seat Leakage

Contoured Trim

Valve Size		Body ⁽¹⁾ Rating	Seat Type	Packing Material	Temperature Range ⁽²⁾				Cryogenic Extension		Seat Leakage IEC 60534-4 and ANSI and FCI 70.2 Class	
Inch	mm				Standard Bonnet		Extension Bonnet		min.	max.		
					min.	max.	min.	max.				
0.75 to 8	20 to 200	ASME Class 150 to 2500 and equivalent PN	Metal	PTFE, LE or LE FireSafe Packing	-20°F (-29°C)	+450°F (+232°C)	-50°F (-46°C)	+800°F (+427°C)			IV	V
				Graphite Packing	-20°F (-29°C)	+800°F (+427°C)	-50°F (-46°C)	+800°F (+427°C)				
				V-ring					-320°F (-196°C)	+212°F (+100°C)		
			Soft Seat ⁽⁴⁾	Any	-20°F (-29°C)	+450°F (+232°C)	-50°F (-46°C)	+450°F (+232°C)			VI	

Lo-dB and Anti-Cavitation Trim (1 or 2 Stage Design)³

Valve Size		Body ⁽¹⁾ Rating	Seat Type	Packing Material	Temperature Range ⁽²⁾				Cryogenic Extension		Seat Leakage IEC 60534-4 and ANSI and FCI 70.2 Class	
Inch	mm				Standard Bonnet		Extension Bonnet		min.	max.		
					min.	max.	min.	max.				
0.75 to 8	20 to 200	ASME Class 150 to 2500 and equivalent PN	Metal	PTFE, LE or LE FireSafe Packing	-20°F (-29°C)	+450°F (+232°C)	-50°F (-46°C)	+800°F (+427°C)			IV	V
				Graphite Packing	-20°F (-29°C)	+800°F (+427°C)	-50°F (-46°C)	+800°F (+427°C)				
				V-ring					-320°F (-196°C)	+212°F (+100°C)		

- ASME Class 900-1500 available only in 0.75 to 4 inch (20 to 100 mm) sizes.
ASME Class 2500 available only in 0.75 to 2 inch (20 to 50 mm) sizes.
- See Materials of Construction Tables for other temperature limitations.
- 2-Stage design only available with Quick Change seat rings.
- Soft seat is limited to a maximum of 1000 psi (70 bar) shut-off and a maximum of 450°F (232°C).

Masonellan 21000 Series products meet design and materials requirements of PED Directive 2014/68/EU.

Ratings and Connections¹

Valve Size		ASME Class 150 (PN 20)					ASME Class 300 (PN 50)					ASME Class 600 (PN 100)				
Inch	mm	RF	SW	THD	RTJ	BW	RF	SW	THD	RTJ	BW	RF	SW	THD	RTJ	BW
0.75	20	X	X	X			X	X	X	X		X	X	X	X	
1	25	X	X	X			X	X	X	X		X	X	X	X	
1.5	40	X	X	X			X	X	X	X		X	X	X	X	
2	50	X	X	X		X	X	X	X	X	X	X	X	X	X	X
3	80	X				X	X			X	X	X			X	X
4	100	X				X	X			X	X	X			X	X
6	150	X				X	X			X	X	X			X	X
8	200	X				X	X			X	X	X			X	X

Valve Size		ASME Class 900 (PN 150) ⁽⁴⁾					ASME Class 1500 (PN 250) ⁽⁴⁾					ASME Class 2500 (PN 420) ³				
Inch	mm	RF	SW	THD	RTJ	BW	RF	SW	THD	RTJ	BW	RF	SW	THD	RTJ	BW
0.75	20	X	X		X		X	X		X		X	X		X	
1	25	X	X		X		X	X		X		X	X		X	
1.5	40	X	X		X		X	X		X		X	X		X	
2	50	X	X		X	X	X	X		X	X	X	X		X	X
3	80	X			X	X	X			X	X					
4	100	X			X	X	X			X	X					

1. Standard flange finish of AARH = 125 to 250 µin (Ra = 3.2 to 6.3 µm). Other flange facings and surface finishes available.

2. Sizes, ratings and end connections available in both globe and angle body styles.

3. Butt weld end connections for ASME Class 2500 available only in 2 inch (50 mm).

4. Butt weld end connections for ASME Class 900 to 1500 available only in 2 inch (50 mm), 3 inch (80 mm) and 4 inch (100 mm)

C_V and F_L Versus Travel

Contoured Trim

Direction: FLOW-TO-OPEN (FTO)
Flow Characteristic: LINEAR

Percent of Travel							10	20	30	40	50	60	70	80	90	100	
F _L							0.93	0.93	0.92	0.92	0.91	0.91	0.91	0.9	0.9	0.9	0.9
Valve Size		ASME Rating	Orifice Diameter		Travel		Rated C _V										
Inch	mm		Inch	mm	Inch	mm											
Close clearance 0.75 and 1 ⁽¹⁾	Close clearance 20 and 25	150-600	0.125	3.2	0.8	20.3	0.01	0.02	0.03	0.04	0.05	0.06	0.07	0.08	0.09	0.1	
							0.02	0.04	0.06	0.07	0.09	0.11	0.13	0.15	0.18	0.2	
			0.25	6.4	0.8	20.3	0.03	0.06	0.08	0.11	0.13	0.16	0.19	0.23	0.27	0.3	
							0.04	0.08	0.11	0.14	0.18	0.22	0.26	0.3	0.36	0.4	
							0.06	0.12	0.17	0.22	0.27	0.32	0.38	0.45	0.54	0.6	
							0.08	0.16	0.22	0.29	0.36	0.43	0.51	0.6	0.72	0.8	
0.1	0.2	0.28	0.36	0.45	0.54	0.64	0.76	0.9	1								
0.75	20	150-1500	0.25	6.4	0.8	20.3	0.15	0.31	0.46	0.61	0.77	0.94	1.12	1.31	1.5	1.7	
							0.2	0.4	0.6	0.9	1.1	1.3	1.5	1.7	1.9	2.1	
			0.375	9.5	0.8	20.3	0.3	0.6	0.8	1.1	1.3	1.6	1.8	2.1	2.3	2.6	
							0.4	0.7	1	1.3	1.6	1.9	2.3	2.6	2.9	3.2	
							0.34	0.68	1.02	1.36	1.72	2.11	2.51	2.93	3.36	3.8	
			0.5	12.7	0.8	20.3	0.5	1	1.5	1.9	2.4	2.8	3.3	3.8	4.2	4.7	
							0.54	1.07	1.6	2.15	2.72	3.33	3.96	4.62	5.3	6	
			0.812	20.6	0.8	20.3	0.9	1.7	2.5	3.3	4	4.9	5.6	6.4	7.2	8	
							1.1	2.1	3.1	4.1	5.1	6	7	8	9	10	
							1.09	2.15	3.21	4.3	5.45	6.65	7.92	9.24	10.6	12	
1	25	150-1500	0.25	6.4	0.8	20.3	0.15	0.31	0.46	0.61	0.77	0.94	1.12	1.31	1.5	1.7	
							0.2	0.4	0.6	0.9	1.1	1.3	1.5	1.7	1.9	2.1	
			0.375	9.5	0.8	20.3	0.3	0.6	0.8	1.1	1.3	1.6	1.8	2.1	2.3	2.6	
							0.4	0.7	1	1.3	1.6	1.9	2.3	2.6	2.9	3.2	
							0.34	0.68	1.02	1.36	1.73	2.11	2.51	2.93	3.36	3.8	
			0.5	12.7	0.8	20.3	0.5	1	1.5	1.9	2.4	2.8	3.3	3.8	4.2	4.7	
							0.54	1.08	1.61	2.15	2.72	3.33	4	4.63	5.31	6	
			0.812	20.6	0.8	20.3	0.9	1.7	2.5	3.3	4.1	4.9	5.6	6.4	7.2	8	
							1.1	2.1	3.1	4.1	5.1	6	7	8	9	10	
							1.09	2.16	3.22	4.31	5.45	6.66	7.93	9.25	10.6	12	
1.5	40	150-1500	0.25	6.4	0.8	20.3	0.15	0.31	0.46	0.61	0.77	0.94	1.12	1.31	1.5	1.7	
							0.2	0.4	0.6	0.9	1.1	1.3	1.5	1.7	1.9	2.1	
			0.375	9.5	0.8	20.3	0.3	0.6	0.8	1.1	1.3	1.6	1.8	2.1	2.3	2.6	
							0.4	0.7	1	1.3	1.6	1.9	2.3	2.6	2.9	3.2	
							0.34	0.68	1.02	1.36	1.73	2.11	2.51	2.93	3.36	3.8	
			0.5	12.7	0.8	20.3	0.5	1	1.4	1.8	2.3	2.7	3.2	3.6	4.1	4.5	
							0.54	1.08	1.61	2.15	2.72	3.33	4	4.63	5.31	6	
			0.812	20.6	0.8	20.3	0.9	1.7	2.5	3.3	4	4.8	5.6	6.4	7.2	8	
							1.1	2.1	3.1	4.1	5.1	6.1	7	8	9	10	
							1.18	2.33	3.48	4.66	5.9	7.2	8.58	10	11.5	13	
			0.994	25.2	0.8	20.3	2.11	4.18	6.06	7.91	9.89	11.67	13.65	15.39	16.65	18	
							2.5	4.6	6.8	9	11.1	13.3	15.5	17.7	19.8	22	
			1.25	31.8	0.8	20.3	2.27	4.49	6.7	8.97	11.3	13.9	16.5	19.3	22.1	25	
1.625	41.3	0.8	20.3	3.17	6.29	9.38	12.6	15.9	19.4	23.1	27	31	35				

Standard Bellows Seal construction available for ASME Class 150 - 300 (PN 20 - PN 50) and capacities of C_V = 1.7 and higher.

1. Close clearance 0.75 and 1 are available in quick change trim only (Model 21114), Class 150-600 only.

2. Models 21614 and 21615 available only in C_V ranges as indicated by green background.

C_V and F_L Versus Travel

Contoured Trim

Direction: FLOW-TO-OPEN (FTO)
Flow Characteristic: LINEAR

Percent of Travel							10	20	30	40	50	60	70	80	90	100			
F _L							0.93	0.93	0.92	0.92	0.91	0.91	0.91	0.9	0.9	0.9	0.9		
Valve Size		ASME Rating	Orifice Diameter		Travel		Rated C _V												
Inch	mm		Inch	mm	Inch	mm													
2	50	150-1500	0.25	6.4	0.8	20.3	0.15	0.31	0.46	0.61	0.77	0.94	1.12	1.31	1.5	1.7			
							0.2	0.4	0.6	0.9	1.1	1.3	1.5	1.7	1.9	2.1			
			0.375	9.5	0.8	20.3	0.3	0.6	0.8	1.1	1.3	1.6	1.8	2.1	2.3	2.6	2.9	3.2	
							0.4	0.7	1	1.3	1.6	1.9	2.3	2.6	2.9	3.2			
							0.34	0.68	1.02	1.36	1.73	2.11	2.51	2.93	3.36	3.8			
							0.5	1	1.4	1.8	2.3	2.7	3.2	3.6	4.1	4.5			
			0.5	12.7	0.8	20.3	0.54	1.08	1.61	2.15	2.72	3.33	4	4.63	5.31	6			
							0.9	1.7	2.5	3.2	4	4.9	5.6	6.4	7.2	8			
			0.812	20.6	0.8	20.3	1.1	2.1	3.1	4.1	5.1	6.1	7	8	9	10			
							1.36	2.7	4.02	5.38	6.81	8.32	9.91	11.6	13.3	15			
0.994	25.2	0.8	20.3	2.22	4.41	6.4	8.35	10.44	12.32	14.4	16.25	17.58	19						
				2.5	4.6	6.8	9	11.1	13.3	15.5	17.7	19.8	22						
1.25	31.8	0.8	20.3	2.36	4.67	6.97	9.33	11.8	14.4	17.2	20.1	23	26						
1.625	41.3	0.8	20.3	4.17	8.27	12.3	16.5	20.9	25.5	30.4	35.5	40.7	46						
3	80	150-1500	0.994	25.2	1.5	38.1	2.34	4.65	6.74	8.79	11	12.97	15.16	17.1	18.5	20			
							3	5.7	8.4	11	13.7	16.3	19	21.7	24.3	27			
			1.25	31.8	1.5	38.1	2.81	5.57	8.31	11.1	14.1	17.2	20.5	23.9	27.4	31			
							4.5	8.4	12.3	16.3	20.2	24.2	28.1	32.1	36	40			
			1.625	41.3	1.5	38.1	4.26	8.45	12.6	16.9	21.3	26.1	31.1	36.2	41.6	47			
							6.7	12.6	18.5	24.5	30.4	36.3	42.2	48.1	54.1	60			
			2	50.8	1.5	38.1	8.43	16.7	24.26	31.65	39.57	46.68	54.58	61.57	66.6	72			
							9.4	17.7	25.9	34.3	42.5	50.8	59.1	67.4	75.7	84			
			2.625	66.7	1.5	38.1	10	20	31	43	58	73	86	95	103	110			
							2.34	4.65	6.74	8.79	11	12.97	15.16	17.1	18.5	20			
4	100	150-1500	0.994	25.2	1.5	38.1	2.34	4.65	6.74	8.79	11	12.97	15.16	17.1	18.5	20			
							3	5.7	8.3	11	13.7	16.3	19	21.7	24.3	27			
			1.25	31.8	1.5	38.1	4.5	8.4	12.3	16.3	20.3	24.2	28.1	32.1	36	40			
							4.44	8.81	13.1	17.6	22.3	27.2	32.4	37.8	43.3	49			
			1.625	41.3	1.5	38.1	6.7	12.6	18.5	24.4	30.4	36.3	42.2	48.1	54.1	60			
							8.67	17.2	24.93	32.53	40.67	47.97	56.1	63.28	68.45	74			
			2	50.8	1.5	38.1	9.4	17.6	26	34.2	42.5	50.8	59.1	67.4	75.7	84			
							10.3	20.3	30.3	40.6	51.3	62.7	74.7	87.1	99.9	113			
			2.625	66.7	1.5	38.1	14	26.5	38.9	51.4	63.8	76.2	88.7	101.1	113.6	126			
							16.4	30.9	45.4	59.9	74.4	88.9	103.4	118	132.5	147			
3.5	88.9	1.5	38.1	19.6	37.2	54.6	72.2	89.6	107.1	124.6	142.1	159.5	177						
				17.7	35.1	52.3	70	88.6	108	129	150	172	195						
6	150	150-600	2	50.8	2	50.8	9.5	18.8	27.3	35.6	44.5	52.5	61.4	69.3	74.9	81			
			2.625	66.7	2	50.8	11.4	22.7	33.8	45.2	57.2	69.9	83.2	97.2	111	126			
			3.5	88.9	2	50.8	18.9	37.4	55.7	74.6	94.5	115	137	160	184	208			
			4.375	111	2	50.8	35.13	69.7	101	131.9	164.9	194.5	227.4	256.5	277.5	300			
			5	127	2	50.8	36.3	71.9	107	143	182	222	264	308	354	400			
8	200	150-600	3.5	88.9	2	50.8	20	40	60	80	101	124	148	172	197	224			
			4.375	111	2	50.8	37	74	108	141	176	207	243	274	296	320			
			5	127	2	50.8	37	75	112	148	187	230	274	319	365	415			
			6.25	158.7	2.5	63.5	57	115	173	228	289	355	422	493	563	640			

Standard Bellows Seal construction available for ASME Class 150 - 300 (PN 20 - PN 50) and capacities of C_V = 1.7 and higher.

1. Close clearance 0.75 and 1 are available in quick change trim (Model 21114), Class 150-600 only.
2. Models 21614 and 21615 available only in C_V ranges as indicated by green background.

C_V and F_L Versus Travel

Contoured Trim

Direction: FLOW-TO-OPEN (FTO)
Flow Characteristic: EQUAL PERCENTAGE

Percent of Travel							10	20	30	40	50	60	70	80	90	100	
F _L							0.93	0.93	0.93	0.93	0.93	0.92	0.92	0.91	0.91	0.91	0.90
Valve Size		ASME Rating	Orifice Diameter		Travel		Rated C _V										
Inch	mm		Inch	mm	Inch	mm											
Close clearance 0.75 and 1 ⁽¹⁾	Close clearance 20 and 25	150-600	0.125	3.2	0.38	9.53	0.008 ⁽³⁾	0.01 ⁽³⁾	0.012	0.014	0.016	0.02	0.03	0.05	0.075	0.1	
							0.009 ⁽³⁾	0.01 ⁽³⁾	0.012	0.015	0.026	0.036	0.056	0.09	0.13	0.2	
			0.25	6.4	0.8	20.3	0.015 ⁽³⁾	0.018	0.025	0.032	0.042	0.064	0.09	0.13	0.19	0.29	0.4
							0.016 ⁽³⁾	0.019	0.026	0.036	0.05	0.08	0.12	0.19	0.29	0.4	
							0.017 ⁽³⁾	0.02	0.035	0.06	0.085	0.11	0.15	0.23	0.35	0.6	
							0.018	0.023	0.036	0.062	0.088	0.12	0.19	0.3	0.45	0.7	
							0.019	0.025	0.04	0.06	0.09	0.14	0.22	0.34	0.52	0.8	
0.02	0.03	0.05	0.07	0.12	0.16	0.25	0.37	0.6	1								
0.75	20	150-1500	0.25	6.4	0.8	20.3	0.05	0.08	0.11	0.18	0.3	0.5	0.8	1.1	1.5	1.7	
							0.1	0.1	0.1	0.2	0.2	0.4	0.6	0.9	1.4	2.1	
			0.375	9.5	0.8	20.3	0.1	0.1	0.1	0.2	0.3	0.5	0.7	1.1	1.7	2.6	
							0.1	0.1	0.1	0.2	0.4	0.6	0.9	1.3	2.1	3.2	
							0.12	0.17	0.24	0.39	0.68	1.13	1.76	2.5	3.26	3.8	
							0.1	0.1	0.2	0.3	0.5	0.8	1.3	2	3	4.7	
			0.5	12.7	0.8	20.3	0.18	0.27	0.38	0.62	1.07	1.79	2.77	3.95	5.14	6	
							0.3	0.3	0.4	0.6	0.9	1.4	2.1	3.3	5.2	8	
			0.812	20.6	0.8	20.3	0.3	0.4	0.5	0.7	1.1	1.7	2.7	4.2	6.5	10	
							0.43	0.6	0.86	1.22	2.32	4.3	6.8	9.13	10.7	12	
							0.05	0.08	0.11	0.18	0.3	0.5	0.8	1.1	1.5	1.7	
							0.1	0.1	0.1	0.2	0.2	0.4	0.6	0.9	1.4	2.1	
0.375	9.5	0.8	20.3	0.1	0.1	0.1	0.2	0.3	0.5	0.7	1.1	1.7	2.6				
				0.1	0.1	0.1	0.2	0.4	0.6	0.9	1.3	2.1	3.2				
				0.12	0.17	0.24	0.39	0.68	1.13	1.76	2.5	3.26	3.8				
				0.1	0.1	0.2	0.3	0.5	0.8	1.3	2	3	4.7				
0.5	12.7	0.8	20.3	0.18	0.27	0.38	0.62	1.07	1.79	2.77	3.95	5.14	6				
				0.3	0.3	0.4	0.6	0.9	1.4	2.1	3.3	5.2	8				
0.812	20.6	0.8	20.3	0.3	0.4	0.5	0.7	1.1	1.7	2.7	4.2	6.4	10				
				0.4	0.6	0.86	1.22	2.32	4.3	6.8	9.13	10.7	12				
				0.05	0.08	0.11	0.18	0.3	0.5	0.8	1.1	1.5	1.7				
				0.1	0.1	0.1	0.2	0.2	0.4	0.6	0.9	1.4	2.1				
0.375	9.5	0.8	20.3	0.1	0.1	0.1	0.2	0.3	0.5	0.7	1.1	1.7	2.6				
				0.1	0.1	0.1	0.2	0.4	0.6	0.9	1.3	2.1	3.2				
				0.12	0.17	0.24	0.39	0.68	1.13	1.76	2.5	3.26	3.8				
				0.1	0.1	0.2	0.3	0.5	0.8	1.3	2	3	4.7				
0.5	12.7	0.8	20.3	0.18	0.27	0.38	0.62	1.07	1.79	2.77	3.95	5.14	6				
				0.3	0.3	0.4	0.6	0.9	1.4	2.1	3.3	5.2	8				
0.812	20.6	0.8	20.3	0.3	0.4	0.5	0.7	1.1	1.7	2.7	4.2	6.4	10				
				0.4	0.6	0.86	1.22	2.32	4.3	6.8	9.13	10.7	12				
				0.05	0.08	0.11	0.18	0.3	0.5	0.8	1.1	1.5	1.7				
				0.1	0.1	0.1	0.2	0.2	0.4	0.6	0.9	1.4	2.1				
0.375	9.5	0.8	20.3	0.1	0.1	0.1	0.2	0.3	0.5	0.7	1.1	1.7	2.6				
				0.1	0.1	0.1	0.2	0.4	0.6	0.9	1.3	2.1	3.2				
				0.12	0.17	0.24	0.39	0.68	1.13	1.76	2.5	3.26	3.8				
				0.1	0.1	0.2	0.3	0.5	0.8	1.3	2	3	4.7				
0.5	12.7	0.8	20.3	0.18	0.27	0.38	0.62	1.07	1.79	2.77	3.95	5.14	6				
				0.3	0.3	0.4	0.6	0.9	1.4	2.1	3.3	5.2	8				
0.812	20.6	0.8	20.3	0.3	0.4	0.4	0.6	1	1.6	2.4	3.7	5.8	9				
				0.4	0.59	0.82	1.34	2.32	3.87	6.01	8.57	11.1	13				
				0.43	0.73	1.14	1.73	2.69	4.61	6.93	10.76	14.84	18				
				0.4	0.7	1	1.6	2.5	3.8	6	10.5	16.4	22				
1.25	31.8	0.8	20.3	0.77	1.13	1.58	2.58	4.46	7.45	11.6	16.5	21.4	25				
1.625	41.3	0.8	20.3	1.3	1.7	2.51	3.56	6.76	12.5	19.8	26.6	31.3	35				

1. Close clearance 0.75 and 1 are available in quick change trim (Model 21114), Class 150-600 only.
 2. Models 21614 and 21615 available only in C_V ranges as indicated by green background.
 3. Throttling at less than minimum operable C_V levels for extended period of time can result in trim damage. Also, rangeability vary from 50:1 to 12:1 (Consult Engineering).

C_V and F_L Versus Travel

Contoured Trim

Direction: FLOW-TO-OPEN (FTO)
Flow Characteristic: EQUAL PERCENTAGE

Percent of Travel							10	20	30	40	50	60	70	80	90	100				
F _L							0.93	0.93	0.93	0.93	0.93	0.92	0.92	0.91	0.91	0.91	0.90			
Valve Size		ASME Rating	Orifice Diameter		Travel		Rated C _V													
Inch	mm		Inch	mm	Inch	mm														
2	50	150-1500	0.25	6.4	0.8	20.3	0.05	0.08	0.11	0.18	0.3	0.5	0.8	1.1	1.5	1.7				
							0.1	0.1	0.1	0.2	0.2	0.4	0.6	0.9	1.4	2.1				
			0.375	9.5	0.8	20.3	0.1	0.1	0.1	0.2	0.3	0.5	0.7	1.1	1.7	2.6				
							0.1	0.1	0.1	0.2	0.4	0.6	0.9	1.3	2.1	3.2				
							0.12	0.17	0.24	0.39	0.68	1.13	1.76	2.5	3.26	3.8				
							0.1	0.1	0.2	0.3	0.5	0.8	1.3	2	3	4.7				
			0.5	12.7	0.8	20.3	0.18	0.27	0.38	0.62	1.07	1.79	2.77	3.95	5.14	6				
							0.3	0.3	0.4	0.6	0.9	1.4	2.1	3.3	5.2	8				
			0.812	20.6	0.8	20.3	0.3	0.4	0.4	0.6	1	1.6	2.4	3.8	5.8	9				
							0.46	0.68	0.95	1.55	2.68	4.47	6.93	9.88	12.9	15				
0.46	0.77	1.2					1.82	2.84	4.87	7.32	11.36	15.67	19							
0.994	25.2	0.8	20.3	0.4	0.7	1	1.6	2.5	3.8	6	10.5	16.4	22							
				0.8	1.17	1.64	2.68	4.64	7.75	12	17.1	22.3	26							
1.625	41.3	0.8	20.3	1.7	2.3	3.29	4.69	8.88	16.5	26.1	35	41.2	46							
3	80	150-1500	0.994	25.2	1.5	38.1	0.48	0.81	1.26	1.92	2.99	5.13	7.7	11.96	16.49	20				
							0.6	0.8	1.2	1.9	3	4.7	7.3	11.2	17.4	27				
			1.25	31.8	1.5	38.1	0.95	1.4	1.96	3.2	5.53	9.24	14.3	20.4	26.6	31				
							1	1.2	1.9	2.9	4.5	6.9	10.7	16.6	25.8	40				
			1.625	41.3	1.5	38.1	1.45	2.12	2.97	4.85	8.39	14	21.7	31	40.3	47				
							1.3	2	3	4.7	7.2	11.2	17.4	27.2	45.6	65				
			2	50.8	1.5	38.1	1.73	2.93	4.55	6.91	10.76	18.45	27.72	43	59.36	72				
							2.2	2.6	3.9	6.1	9.4	14.6	22.6	36.2	61.3	84				
			2.625	66.7	1.5	38.1	4	5.5	7.88	11.2	21.2	39.4	62.3	83.7	98.5	110				
							0.994	25.2	1.5	38.1	0.74	1.14	1.76	2.07	2.99	5.13	7.7	11.96	16.49	20
4	100	150-1500	1.25	31.8	1.5	38.1	0.6	0.8	1.2	1.9	3	4.7	7.3	11.2	17.4	27				
							1	1.2	1.9	2.9	4.5	6.9	10.7	16.6	25.8	40				
			1.625	41.3	1.5	38.1	1.51	2.21	3.09	5.06	8.74	14.6	22.7	32.3	42	49				
							1.3	2	3	4.7	7.3	11.3	17.5	27.1	43.3	65				
			2	50.8	1.5	38.1	2.73	4.22	6.51	7.66	11.1	18.97	28.49	44.24	61	74				
							2.2	2.6	3.9	6.1	9.3	14.5	22.6	34.9	56.2	84				
			2.625	66.7	1.5	38.1	3.47	5.09	7.14	11.7	20.2	33.7	52.2	74.5	96.8	113				
							3.8	4	5.7	8.8	13.7	21.2	32.7	52.4	87.8	122				
			3.5	88.9	1.5	38.1	3.8	4.5	6.9	10.6	16.5	25.5	40.1	73.5	113	147				
							3.9	5.3	8.3	12.8	19.8	34	72.2	113.5	149.8	177				
7	9.7	14					19.9	37.6	69.8	110	148	175	195							
2	50.8	2					50.8	2.99	4.62	7.13	8.38	12.1	20.76	31.19	48.42	66.78	81			
6	150	150-600	2.625	66.7	2	50.8	3.87	5.68	7.96	13	22.5	37.5	58.3	83	108	126				
							3.5	88.9	2	50.8	6.4	9.37	13.1	21.5	37.1	62	96.2	137	178	208
			4.375	111	2	50.8	11	17.1	26.4	31	44.85	76.89	115.5	179.34	247.35	300				
			5	127	2	50.8	14.4	20	28.7	40.7	77.2	143	227	304	358	400				
			3.5	88.9	2	50.8	7	10	15	24	40	72	112	154	197	224				
8	200	150-600	4.375	111	2	50.8	8	13	20	31	48	82	123	191	264	320				
							5	127	2	50.8	13	19	28	44	74	133	207	285	365	415
			6.25	158.7	2.5	63.5	20	30	43	68	115	205	320	440	562	640				

1. Close clearance 0.75 and 1 are available in quick change trim (Model 21114), Class 150-600 only.
2. Models 21614 and 21615 available only in C_V ranges as indicated by green background.
3. Throttling at less than minimum operable C_V levels for extended period of time can result in trim damage. Also, rangeability vary from 50:1 to 12:1 (Consult Engineering).

C_v and F_L Versus Travel

Contoured Plug

Direction: FLOW-TO-OPEN (FTO)
Flow Characteristic: MODIFIED PERCENT

Percent of Travel							10	20	30	40	50	60	70	80	90	100	
F _L							0.93	0.93	0.93	0.93	0.93	0.92	0.92	0.91	0.91	0.91	0.90
Valve Size		ASME Rating	Orifice Diameter		Travel		Rated C _v										
Inch	mm		Inch	mm	Inch	mm											
0.75	20	150-1500	0.25	6.4	0.8	20.3	0.04	0.07	0.14	0.28	0.5	0.73	0.99	1.28	1.52	1.7	
							0.1	0.1	0.2	0.3	0.5	0.8	1	1.3	1.7	2	
			0.375	9.5	0.8	20.3	0.1	0.1	0.2	0.4	0.6	0.9	1.3	1.7	2.1	2.6	
							0.1	0.1	0.3	0.5	0.8	1.1	1.6	2	2.6	3.2	
							0.09	0.15	0.31	0.64	1.13	1.64	2.22	2.86	3.4	3.8	
							0.1	0.2	0.4	0.8	1.2	1.7	2.3	3	3.8	4.7	
			0.5	12.7	0.8	20.3	0.14	0.24	0.49	1	1.78	2.59	3.5	4.5	5.38	6	
							0.4	0.4	0.7	1.3	2	2.9	3.9	5.1	6.5	8	
			0.812	20.6	0.8	20.3	0.4	0.5	0.9	1.6	2.5	3.6	4.9	6.4	8.1	10	
							0.32	0.74	1.27	3.25	5.47	7.78	9.6	10.85	11.57	12	
							0.04	0.07	0.14	0.28	0.5	0.73	0.99	1.28	1.52	1.7	
							0.1	0.1	0.2	0.3	0.5	0.8	1	1.3	1.7	2	
1	25	150-1500	0.25	6.4	0.8	20.3	0.04	0.07	0.14	0.28	0.5	0.73	0.99	1.28	1.52	1.7	
							0.1	0.1	0.2	0.3	0.5	0.8	1	1.3	1.7	2	
			0.375	9.5	0.8	20.3	0.1	0.1	0.2	0.4	0.6	0.9	1.3	1.7	2.1	2.6	
							0.1	0.1	0.3	0.5	0.8	1.1	1.6	2	2.6	3.2	
							0.09	0.15	0.31	0.64	1.13	1.64	2.22	2.86	3.4	3.8	
							0.1	0.2	0.4	0.8	1.2	1.7	2.3	3	3.8	4.7	
			0.5	12.7	0.8	20.3	0.14	0.24	0.49	1	1.78	2.59	3.5	4.5	5.38	6	
							0.4	0.4	0.7	1.3	2	2.9	3.9	5.1	6.5	8	
			0.812	20.6	0.8	20.3	0.4	0.5	0.9	1.6	2.5	3.6	4.9	6.4	8.1	10	
							0.32	0.74	1.27	3.25	5.47	7.78	9.6	10.85	11.57	12	
							0.04	0.07	0.14	0.28	0.5	0.73	0.99	1.28	1.52	1.7	
							0.1	0.1	0.2	0.3	0.5	0.8	1	1.3	1.7	2	
1.5	40	150-1500	0.25	6.4	0.8	20.3	0.04	0.07	0.14	0.28	0.5	0.73	0.99	1.28	1.52	1.7	
							0.1	0.1	0.2	0.3	0.5	0.8	1	1.3	1.7	2.1	
			0.375	9.5	0.8	20.3	0.1	0.1	0.2	0.4	0.6	0.9	1.3	1.7	2.1	2.6	
							0.1	0.1	0.3	0.5	0.8	1.1	1.6	2	2.6	3.2	
							0.09	0.15	0.31	0.64	1.13	1.64	2.22	2.86	3.4	3.8	
							0.1	0.2	0.4	0.8	1.2	1.7	2.3	3	3.8	4.7	
			0.5	12.7	0.8	20.3	0.14	0.24	0.49	1	1.78	2.59	3.5	4.5	5.38	6	
							0.4	0.4	0.7	1.3	2	2.9	3.9	5.1	6.5	8	
			0.812	20.6	0.8	20.3	0.4	0.5	0.9	1.6	2.5	3.6	4.9	6.4	8.1	10	
							0.29	0.52	1.07	2.18	3.86	5.62	7.6	9.77	11.65	13	
							0.41	0.71	1.48	3.01	5.34	7.78	10.53	13.53	16.13	18	
							0.4	0.9	2	3.5	5.5	7.9	10.8	14.1	17.9	22	
0.994	25.2	0.8	20.3	0.4	0.9	2	3.5	5.5	7.9	10.8	14.1	17.9	22				
1.25	31.8	0.8	20.3	0.68	1.55	2.66	6.77	11.4	16.2	20	22.6	24.11	25				
1.625	41.3	0.8	20.3	0.95	2.17	3.72	9.48	15.97	22.69	28	31.65	33.76	35				

C_v and F_L Versus Travel

Contoured Plug

Direction: FLOW-TO-OPEN (FTO)
Flow Characteristic: MODIFIED PERCENT

Percent of Travel							10	20	30	40	50	60	70	80	90	100	
F _L							0.93	0.93	0.93	0.93	0.93	0.92	0.92	0.91	0.91	0.91	0.90
Valve Size		ASME Rating	Orifice Diameter		Travel		Rated C _v										
Inch	mm		Inch	mm	Inch	mm											
2	50	150-1500	0.25	6.4	0.8	20.3	0.04	0.07	0.14	0.28	0.5	0.73	0.99	1.28	1.52	1.7	
							0.1	0.1	0.2	0.3	0.5	0.8	1	1.3	1.7	2.1	
			0.375	9.5	0.8	20.3	0.1	0.1	0.2	0.4	0.6	0.9	1.3	1.7	2.1	2.6	3.2
							0.09	0.15	0.31	0.64	1.13	1.64	2.22	2.86	3.4	3.8	
							0.1	0.2	0.4	0.8	1.2	1.7	2.3	3	3.8	4.7	
							0.14	0.24	0.49	1	1.78	2.59	3.5	4.5	5.38	6	
			0.5	12.7	0.8	20.3	0.4	0.4	0.7	1.3	2	2.9	3.9	5.1	6.5	8	
							0.4	0.5	0.9	1.6	2.5	3.6	4.9	6.4	8.1	10	
			0.812	20.6	0.8	20.3	0.34	0.59	1.23	2.51	4.45	6.48	8.77	11.28	13.44	15	
							0.43	0.75	1.56	3.18	5.64	8.21	11.11	14.28	17	19	
0.994	25.2	0.8	20.3	0.4	0.9	2	3.5	5.5	7.9	10.8	14.1	17.8	22				
				1.25	31.8	0.8	20.3	0.59	1.03	2.14	4.35	7.71	11.23	15.2	19.54	23.3	26
				1.625	41.3	0.8	20.3	1.24	2.85	4.89	12.46	20.99	29.82	36.81	41.59	44.37	46
3	80	150-1500	0.994	25.2	1.5	38.1	0.45	0.79	1.64	3.35	5.93	8.64	11.7	15	17.92	20	
							0.7	1.1	2.4	4.3	6.7	9.7	13.2	17.3	21.9	27	
			1.25	31.8	1.5	38.1	0.7	1.23	2.55	5.19	9.19	13.4	18.13	23.3	27.78	31	
							1.1	1.6	3.6	6.4	10	14.4	19.6	25.6	32.4	40	
			1.625	41.3	1.5	38.1	1.06	1.86	3.86	7.87	13.94	20.3	27.49	35.33	42.12	47	
							1.2	2.3	5.2	9.3	14.5	20.9	28.4	37.1	47	58	
			2	50.8	1.5	38.1	1.63	2.85	5.92	12.05	21.36	31.11	42.11	54.12	64.53	72	
							2.4	3.3	7.6	13.5	21	30.2	41.2	53.8	68	84	
			2.625	66.7	1.5	38.1	2.97	6.82	11.68	29.79	50.18	71.3	88	99.46	106.1	110	
							0.994	25.2	1.5	38.1	0.45	0.79	1.64	3.35	5.93	8.64	11.7
4	100	150-1500	1.25	31.8	1.5	38.1	0.7	1.1	2.4	4.3	6.7	9.7	13.2	17.3	21.9	27	
							1.1	1.6	3.6	6.4	10	14.4	19.6	25.6	32.4	40	
			1.625	41.3	1.5	38.1	1.11	1.94	4.03	8.2	14.53	21.17	28.66	36.83	43.91	49	
							1.2	2.3	5.2	9.3	14.5	20.9	28.4	37.1	47	58	
			2	50.8	1.5	38.1	1.67	2.93	6.08	12.39	21.95	31.98	43.28	55.63	66.32	74	
							2.4	3.3	7.6	13.4	21	30.3	41.2	53.8	68	84	
			2.625	66.7	1.5	38.1	2.56	4.48	9.29	18.92	33.52	48.83	66.09	84.94	101.27	113	
							2.6	4.9	11	19.5	30.5	43.9	59.8	78.1	99.3	122	
			3.5	88.9	1.5	38.1	4.5	5.6	12.6	22.3	34.9	50.4	68.6	89.6	113.5	140	
							4.7	7.1	16	28.3	44.3	63.7	88.5	120.5	151.7	177	
				5.27	12.1	20.7	52.8	88.96	126.4	156.04	176.32	188.08	195				
6	150	150-600	2	50.8	2	50.8	1.83	3.21	6.66	13.56	24.02	35	47.38	60.89	72.6	81	
			2.625	66.7	2	50.8	2.85	4.99	10.36	21.1	37.37	54.44	73.7	94.7	112.92	126	
			3.5	88.9	2	50.8	4.71	8.25	17.1	34.82	61.69	89.88	121.66	156.35	186.41	208	
			4.375	111	2	50.8	6.79	11.89	24.66	50.22	88.98	129.63	175.47	225.51	268.86	300	
			5	127	2	50.8	10.8	24.8	42.48	108.32	182.48	259.28	320.08	361.68	385.8	400	

C_v and F_L Versus Travel

Contoured Plug

Direction: FLOW-TO-CLOSE (FTC)
Flow Characteristic: LINEAR TRIM

Percent of Travel							10	20	30	40	50	60	70	80	90	100				
F _L							0.53	0.56	0.60	0.68	0.75	0.78	0.81	0.84	0.85	0.86				
Valve Size		ASME Rating	Orifice Diameter		Travel		Rated C _v													
Inch	mm		Inch	mm	Inch	mm														
0.75	20	150-1500	0.25	6.4	0.8	20.3	0.225	0.39	0.46	0.61	0.77	0.94	1.12	1.31	1.5	1.7				
							0.28	0.47	0.56	0.75	0.96	1.17	1.39	1.62	1.86	2.1				
							0.35	0.58	0.7	0.93	1.18	1.44	1.72	2	2.3	2.6				
			0.375	9.5	0.8	20.3	0.43	0.72	0.86	1.15	1.46	1.78	2.11	2.47	2.83	3.2				
							0.51	0.85	1.02	1.36	1.72	2.11	2.51	2.93	3.36	3.8				
							0.63	1.06	1.26	1.68	2.13	2.61	3.13	3.63	4.16	4.7				
			0.5	12.7	0.8	20.3	0.81	1.34	1.6	2.15	2.72	3.33	3.96	4.62	5.3	6				
							1.09	1.79	2.14	2.87	3.63	4.43	5.28	6.15	7.08	8				
							1.36	2.24	2.68	3.58	4.54	5.54	6.6	7.69	8.85	10				
			0.812	20.6	0.8	20.3	1.635	2.69	3.21	4.3	5.45	6.65	7.92	9.24	10.6	12				
							0.25	6.4	0.8	20.3	0.225	0.39	0.46	0.61	0.77	0.94	1.12	1.31	1.5	1.7
							0.28	0.47	0.56	0.75	0.96	1.17	1.39	1.62	1.86	2.1				
1	25	150-1500	0.375	9.5	0.8	20.3	0.35	0.58	0.7	0.93	1.18	1.44	1.72	2	2.3	2.6				
							0.43	0.72	0.86	1.15	1.46	1.78	2.11	2.47	2.83	3.2				
							0.51	0.85	1.02	1.36	1.73	2.11	2.51	2.93	3.36	3.8				
			0.5	12.7	0.8	20.3	0.63	1.06	1.26	1.68	2.13	2.61	3.13	3.63	4.16	4.7				
							0.81	1.35	1.61	2.15	2.72	3.33	4	4.63	5.31	6				
							1.09	1.79	2.14	2.87	3.63	4.43	5.28	6.15	7.08	8				
			0.812	20.6	0.8	20.3	1.36	2.24	2.68	3.58	4.54	5.54	6.6	7.69	8.85	10				
							1.635	2.7	3.22	4.31	5.45	6.66	7.93	9.25	10.6	12				
							0.25	6.4	0.8	20.3	0.225	0.39	0.46	0.61	0.77	0.94	1.12	1.31	1.5	1.7
			1.5	40	150-1500	0.375	9.5	0.8	20.3	0.28	0.47	0.56	0.75	0.96	1.17	1.39	1.62	1.86	2.1	
										0.35	0.58	0.7	0.93	1.18	1.44	1.72	2	2.3	2.6	
										0.43	0.72	0.86	1.15	1.46	1.78	2.11	2.47	2.83	3.2	
0.5	12.7	0.8				20.3	0.51	0.85	1.02	1.36	1.73	2.11	2.51	2.93	3.36	3.8				
							0.61	1.01	1.21	1.61	2.04	2.5	3	3.47	3.98	4.5				
							0.81	1.35	1.61	2.15	2.72	3.33	4	4.63	5.31	6				
0.812	20.6	0.8				20.3	1.09	1.79	2.14	2.87	3.63	4.43	5.28	6.15	7.08	8				
							1.36	2.24	2.68	3.58	4.54	5.54	6.6	7.69	8.85	10				
							1.77	2.91	3.48	4.66	5.9	7.2	8.58	10	11.5	13				
0.994	25.2	0.8				20.3	3.15	5.22	6.1	7.91	9.89	11.67	13.65	15.39	16.65	18				
							3.86	6.38	7.41	9.67	12.09	14.27	16.67	18.82	20.36	22				
							1.25	31.8	0.8	20.3	3.4	5.61	6.7	8.97	11.3	13.9	16.5	19.3	22.1	25
1.625	41.3	0.8	20.3	4.76	7.86	9.38	12.6	15.9	19.4	23.1	27	31	35							

1. Models 21614 and 21615 available only in C_v ranges as indicated by green background.

C_v and F_L Versus Travel

Contoured Plug

Direction: FLOW-TO-CLOSE (FTC)
Flow Characteristic: LINEAR TRIM

							Percent of Travel												
							10	20	30	40	50	60	70	80	90	100			
							F _L	0.53	0.56	0.60	0.68	0.75	0.78	0.81	0.84	0.85	0.86		
Valve Size		ASME Rating	Orifice Diameter		Travel		Rated C _v												
Inch	mm		Inch	mm	Inch	mm													
2	50	150-1500	0.25	6.4	0.8	20.3	0.225	0.39	0.46	0.61	0.77	0.94	1.12	1.31	1.5	1.7			
							0.28	0.47	0.56	0.75	0.96	1.17	1.39	1.62	1.86	2.1			
			0.375	9.5	0.8	20.3	0.35	0.58	0.7	0.93	1.18	1.44	1.72	2	2.3	2.6			
							0.43	0.72	0.86	1.15	1.46	1.78	2.11	2.47	2.83	3.2			
			0.5	12.7	0.8	20.3	0.51	0.85	1.02	1.36	1.73	2.11	2.51	2.93	3.36	3.8			
							0.61	1.01	1.21	1.61	2.04	2.5	3	3.47	3.98	4.5			
			0.812	20.6	0.8	20.3	0.81	1.35	1.61	2.15	2.72	3.33	4	4.63	5.31	6			
							1.09	1.79	2.14	2.87	3.63	4.43	5.28	6.15	7.08	8			
			0.994	25.2	0.8	20.3	1.36	2.24	2.68	3.58	4.54	5.54	6.6	7.69	8.85	10			
							2.04	3.38	4.02	5.38	6.81	8.32	9.91	11.6	13.3	15			
1.25	31.8	0.8	20.3	3.33	5.51	6.4	8.35	10.44	12.3	14.4	16.25	17.58	19						
				3.86	6.38	7.41	9.67	12.09	14.27	16.67	18.82	20.36	22						
1.625	41.3	0.8	20.3	3.54	5.84	6.97	9.33	11.8	14.4	17.2	20.1	23	26						
				6.26	10.34	12.3	16.5	20.9	25.5	30.4	35.5	40.7	46						
3	80	150-1500	0.994	25.2	1.5	38.1	3.5	5.8	6.74	8.79	11	12.97	15.2	17.1	18.5	20			
							3.68	6.06	7.24	9.69	12.25	14.95	17.86	20.87	23.88	27			
			1.25	31.8	1.5	38.1	4.22	6.96	8.31	11.1	14.1	17.2	20.5	23.9	27.4	31			
							5.44	8.99	10.7	14.35	18.17	22.17	26.43	30.87	35.39	40			
			1.625	41.3	1.5	38.1	6.39	10.56	12.6	16.9	21.3	26.1	31.1	36.2	41.6	47			
							10.5	17.42	20.22	26.38	32.98	38.9	45.48	51.31	55.5	60			
			2	50.8	1.5	38.1	12.6	20.9	24.26	31.65	39.57	46.68	54.58	61.57	66.6	72			
							11.42	18.9	22.53	30.16	38.11	46.58	55.52	64.76	74.3	84			
			2.625	66.7	1.5	38.1	15	25	31	43	58	73	86	95	103	110			
							15.45	25.38	30.3	40.6	51.3	62.7	74.7	87.1	99.9	113			
4	100	150-1500	0.994	25.2	1.5	38.1	3.5	5.8	6.74	8.79	11	12.97	15.2	17.1	18.5	20			
							3.68	6.06	7.24	9.69	12.25	14.95	17.86	20.87	23.88	27			
			1.25	31.8	1.5	38.1	5.44	8.99	10.7	14.35	18.17	22.17	26.43	30.87	35.39	40			
							6.66	11.01	13.1	17.6	22.3	27.2	32.4	37.8	43.3	49			
			2	50.8	1.5	38.1	10.5	17.42	20.22	26.38	32.98	38.9	45.48	51.31	55.5	60			
							12.95	21.46	24.93	32.53	40.67	47.97	56.1	63.28	68.45	74			
			2.625	66.7	1.5	38.1	11.42	18.9	22.53	30.16	38.11	46.58	55.52	64.76	74.3	84			
							15.45	25.38	30.3	40.6	51.3	62.7	74.7	87.1	99.9	113			
			3.5	88.9	1.5	38.1	17.14	28.35	33.79	45.25	57.16	69.87	83.27	97.13	111.45	126			
							20.01	33.08	39.43	52.77	66.79	81.42	97.25	113.08	129.66	147			
6	150	150-600	2.000	50.8	2	50	24.1	39.83	47.47	63.54	80.42	98.03	117.09	136.15	156.12	177			
							26.55	43.88	52.3	70	88.6	108	129	150	172	195			
			2.625	66.7	2	50	14.18	23.49	27.29	35.6	44.5	52.5	61.4	69.2	74.9	81			
							17.1	28.38	33.8	45.2	57.2	69.9	83.2	97.2	111	126			
			3.5	88.9	2	50	28.35	46.75	55.7	74.6	94.5	115	137	160	184	208			
							52.5	87	101	131.9	164.9	194.5	227.4	256.5	277.5	300			
			4.375	111	2	50	54.45	89.88	107	143	182	222	264	308	354	400			
							5	127	2	50	30	50	60	80	101	124	148	172	197
			8	200	150-600	4.375	111	2	50	54.5	92.8	108	141	176	207	243	274	296	320
										55.5	93.75	112	148	187	230	274	319	365	415
6.25	158.7	2.5				63	85.5	143.7	173	228	289	355	422	493	563	640			

1. Models 21614 and 21615 available only in C_v ranges as indicated by green background.

C_v and F_L Versus Travel

Contoured Plug

Direction: FLOW-TO-CLOSE (FTC)
Flow Characteristic: EQUAL PERCENT

Percent of Travel							10	20	30	40	50	60	70	80	90	100				
F _L							0.53	0.53	0.55	0.63	0.72	0.80	0.80	0.80	0.80	0.80	0.80			
Valve Size		ASME Rating	Orifice Diameter		Travel		Rated C _v													
Inch	mm		Inch	mm	Inch	mm														
0.75	20	150-1500	0.25	6.4	0.8	20.3	0.1	0.1	0.2	0.22	0.3	0.5	0.8	1.1	1.5	1.7				
							0.06	0.11	0.17	0.22	0.38	0.62	0.97	1.38	1.8	2.1				
			0.375	9.5	0.8	20.3	0.07	0.14	0.21	0.27	0.47	0.77	1.2	1.71	2.23	2.6				
							0.08	0.17	0.25	0.33	0.57	0.95	1.48	2.11	2.75	3.2				
							0.2	0.2	0.3	0.39	0.68	1.13	1.76	2.5	3.26	3.8				
							0.24	0.31	0.39	0.5	0.84	1.4	2.17	3.09	4.03	4.7				
			0.5	12.7	0.8	20.3	0.3	0.4	0.5	0.64	1.07	1.79	2.77	3.95	5.14	6				
							0.37	0.53	0.69	0.87	1.43	2.38	3.7	5.27	6.88	8				
			0.812	20.6	0.8	20.3	0.47	0.67	0.87	1.09	1.79	2.98	4.62	6.59	8.6	10				
							0.6	0.8	1.2	1.48	2.32	4.3	6.8	9.13	10.7	12				
							0.25	6.4	0.8	20.3	0.1	0.1	0.2	0.22	0.3	0.5	0.8	1.1	1.5	1.7
							0.375	9.5	0.8	20.3	0.06	0.11	0.17	0.22	0.38	0.62	0.97	1.38	1.8	2.1
0.07	0.14	0.21	0.27	0.47	0.77	1.2					1.71	2.23	2.6							
0.08	0.17	0.25	0.33	0.57	0.95	1.48					2.11	2.75	3.2							
0.2	0.2	0.3	0.39	0.68	1.13	1.76					2.5	3.26	3.8							
0.5	12.7	0.8	20.3	0.24	0.31	0.39	0.5	0.84	1.4	2.17	3.09	4.03	4.7							
				0.3	0.4	0.5	0.64	1.07	1.79	2.77	3.95	5.14	6							
0.812	20.6	0.8	20.3	0.37	0.53	0.69	0.87	1.43	2.38	3.7	5.27	6.88	8							
				0.47	0.67	0.87	1.09	1.79	2.98	4.62	6.59	8.6	10							
				0.6	0.8	1.2	1.48	2.32	4.3	6.8	9.13	10.7	12							
				0.25	6.4	0.8	20.3	0.1	0.1	0.2	0.22	0.3	0.5	0.8	1.1	1.5	1.7			
0.375	9.5	0.8	20.3	0.06	0.11	0.17	0.22	0.38	0.62	0.97	1.38	1.8	2.1							
				0.07	0.14	0.21	0.27	0.47	0.77	1.2	1.71	2.23	2.6							
				0.08	0.17	0.25	0.33	0.57	0.95	1.48	2.11	2.75	3.2							
				0.2	0.2	0.3	0.39	0.68	1.13	1.76	2.5	3.26	3.8							
0.5	12.7	0.8	20.3	0.24	0.31	0.39	0.5	0.84	1.4	2.17	3.09	4.03	4.7							
				0.3	0.4	0.5	0.64	1.07	1.79	2.77	3.95	5.14	6							
0.812	20.6	0.8	20.3	0.37	0.53	0.69	0.87	1.43	2.38	3.7	5.27	6.88	8							
				0.47	0.67	0.87	1.09	1.79	2.98	4.62	6.59	8.6	10							
				0.6	0.8	1.2	1.48	2.32	4.3	6.8	9.13	10.7	12							
				0.25	6.4	0.8	20.3	0.1	0.1	0.2	0.22	0.3	0.5	0.8	1.1	1.5	1.7			
0.375	9.5	0.8	20.3	0.06	0.11	0.17	0.22	0.38	0.62	0.97	1.38	1.8	2.1							
				0.07	0.14	0.21	0.27	0.47	0.77	1.2	1.71	2.23	2.6							
				0.08	0.17	0.25	0.33	0.57	0.95	1.48	2.11	2.75	3.2							
				0.2	0.2	0.3	0.39	0.68	1.13	1.76	2.5	3.26	3.8							
0.5	12.7	0.8	20.3	0.24	0.31	0.39	0.5	0.84	1.4	2.17	3.09	4.03	4.7							
				0.3	0.4	0.5	0.64	1.07	1.79	2.77	3.95	5.14	6							
0.812	20.6	0.8	20.3	0.37	0.53	0.69	0.87	1.43	2.38	3.7	5.27	6.88	8							
				0.42	0.6	0.78	0.98	1.61	2.68	4.16	5.93	7.74	9							
				0.6	0.8	1.1	1.48	2.32	3.87	6.01	8.57	11.1	13							
				0.66	1.03	1.58	1.86	2.69	4.61	6.93	10.76	14.84	18							
0.994	25.2	0.8	20.3	0.81	1.25	1.94	2.28	3.29	5.64	8.47	13.16	18.14	22							
				1.25	31.8	0.8	20.3	1.2	1.6	2.2	2.76	4.46	7.45	11.6	16.5	21.4	25			
1.625	41.3	0.8	20.3	2	2.4	3.5	4.31	6.76	12.5	19.8	26.6	31.3	35							

1. Models 21614 and 21615 available only in C_v ranges as indicated by green background.

Contoured Plug

Direction: FLOW-TO-CLOSE (FTC)
Flow Characteristic: EQUAL PERCENT

Percent of Travel							10	20	30	40	50	60	70	80	90	100	
F _L							0.53	0.53	0.55	0.63	0.72	0.80	0.80	0.80	0.80	0.80	0.80
Valve Size		ASME Rating	Orifice Diameter		Travel		Rated C _v										
Inch	mm		Inch	mm	Inch	mm											
2	50	150-1500	0.25	6.4	0.8	20.3	0.1	0.1	0.2	0.22	0.3	0.5	0.8	1.1	1.5	1.7	
							0.06	0.11	0.17	0.22	0.38	0.62	0.97	1.38	1.8	2.1	
			0.375	9.5	0.8	20.3	0.07	0.14	0.21	0.27	0.47	0.77	1.2	1.71	2.23	2.6	
							0.08	0.17	0.25	0.33	0.57	0.95	1.48	2.11	2.75	3.2	
							0.2	0.2	0.3	0.39	0.68	1.13	1.76	2.5	3.26	3.8	
			0.5	12.7	0.8	20.3	0.24	0.31	0.39	0.5	0.84	1.4	2.17	3.09	4.03	4.7	
							0.3	0.4	0.5	0.64	1.07	1.79	2.77	3.95	5.14	6	
			0.812	20.6	0.8	20.3	0.37	0.53	0.69	0.87	1.43	2.38	3.7	5.27	6.88	8	
							0.42	0.6	0.78	0.98	1.61	2.68	4.16	5.93	7.74	9	
							0.7	1	1.3	1.64	2.68	4.47	6.93	9.88	12.9	15	
0.994	25.2	0.8	20.3	0.7	1.08	1.67	1.97	2.84	4.87	7.32	11.36	15.67	19				
				0.81	1.25	1.94	2.28	3.29	5.64	8.47	13.16	18.14	22				
1.25	31.8	0.8	20.3	1.2	1.6	2.3	2.76	4.64	7.75	12	17.1	22.3	26				
1.625	41.3	0.8	20.3	2.6	3.2	4.6	5.67	8.88	16.5	26.1	35	41.2	46				
3	80	150-1500	0.994	25.2	1.5	38.1	0.74	1.14	1.76	2.07	2.99	5.13	7.7	11.96	16.49	20	
							1.22	1.74	2.35	2.96	4.82	8.05	12.45	17.77	23.17	27	
			1.25	31.8	1.5	38.1	1.4	2	2.7	3.4	5.53	9.24	14.3	20.4	26.6	31	
							1.88	2.53	3.51	4.42	7.13	11.92	18.53	26.37	34.29	40	
			1.625	41.3	1.5	38.1	2.2	3	4.2	5.24	8.39	14	21.7	31	40.3	47	
							2.4	3.71	5.72	6.73	9.75	16.66	25.03	38.86	53.58	65	
			2	50.8	1.5	38.1	2.66	4.1	6.34	7.45	10.76	18.45	27.72	43	59.36	72	
							3.87	5.33	7.4	9.27	15	25	38.87	55.33	72	84	
			2.625	66.7	1.5	38.1	6	7.7	11	13.5	21.2	39.4	62.3	83.7	98.5	110	
							0.994	25.2	1.5	38.1	0.74	1.14	1.76	2.07	2.99	5.13	7.7
4	100	150-1500	1.25	31.8	1.5	38.1	1.22	1.74	2.35	2.96	4.82	8.05	12.45	17.77	23.17	27	
							1.88	2.53	3.51	4.42	7.13	11.92	18.53	26.37	34.29	40	
			1.625	41.3	1.5	38.1	2.3	3.1	4.3	5.41	8.74	14.6	22.7	32.3	42	49	
							2.4	3.71	5.72	6.73	9.75	16.66	25.03	38.86	53.58	65	
			2	50.8	1.5	38.1	2.73	4.22	6.51	7.66	11.1	18.97	28.49	44.24	61	74	
							3.87	5.33	7.4	9.27	15	25	38.87	55.33	72	84	
			2.625	66.7	1.5	38.1	5.2	7.1	10	12.55	20.2	33.7	52.2	74.5	96.8	113	
							5.72	7.63	11.44	14.02	21.79	39.21	61	83.88	107.29	122	
			3.5	88.9	1.5	38.1	6.89	9.19	13.78	16.9	26.25	47.25	73.5	101.06	129.28	147	
							8.3	11.06	16.59	20.35	31.61	56.89	88.5	121.69	155.67	177	
10.5	13.6	19.6					24.1	37.6	69.8	110	148	175	195				
6	150	150-600	2	50.8	2	50.8	3	4.62	7.13	8.38	12.1	20.76	31.19	48.42	66.78	81	
							5.8	8.0	11.1	13.9	22.5	37.5	58.3	83	108	126	
			3.5	88.9	2	50.8	9.6	13.1	18.3	23	37.1	62	96.2	137	178	208	
							11.1	17.1	26.4	31	44.85	76.89	115.5	179.34	247.35	300	
			5	127	2	50.8	21.6	28.0	40.2	49.4	77.2	143	227	304	358	400	
8	200	150-600	3.5	88.9	2	50.8	10.5	14.0	21.0	25.75	40	72	112	154	197	224	
							11.8	18.2	28.2	33.1	48	82	123	191	264	320	
			5	127	2	50.8	19.5	26.6	39.2	47.9	74	133	207	285	365	415	
							30.0	42.0	60.2	73.9	115	205	320	440	562	640	

1. Models 21614 and 21615 available only in C_v ranges as indicated by green background.

C_v and F_L Versus Travel

Contoured Plug

Direction: FLOW-TO-CLOSE (FTC)
Flow Characteristic: MODIFIED PERCENT

Percent of Travel							10	20	30	40	50	60	70	80	90	100	
F _L							0.53	0.53	0.55	0.63	0.72	0.80	0.80	0.80	0.80	0.80	0.80
Valve Size		ASME Rating	Orifice Diameter		Travel		Rated C _v										
Inch	mm		Inch	mm	Inch	mm											
0.75	20	150-1500	0.25	6.4	0.8	20.3	0.06	0.09	0.19	0.3	0.5	0.73	0.99	1.28	1.52	1.7	
							0.07	0.11	0.23	0.36	0.59	0.86	1.17	1.51	1.79	2	
			0.375	9.5	0.8	20.3	0.09	0.14	0.29	0.47	0.77	1.12	1.52	1.96	2.33	2.6	
							0.11	0.18	0.36	0.57	0.95	1.38	1.87	2.41	2.86	3.2	
							0.13	0.21	0.43	0.68	1.13	1.64	2.22	2.86	3.4	3.8	
							0.16	0.26	0.53	0.85	1.39	2.03	2.74	3.53	4.21	4.7	
			0.5	12.7	0.8	20.3	0.2	0.33	0.68	1.08	1.78	2.59	3.51	4.51	5.38	6	
							0.27	0.44	0.91	1.44	2.37	3.46	4.68	6.02	7.17	8	
							0.34	0.55	1.14	1.8	2.97	4.32	5.85	7.52	8.96	10	
							0.48	1.03	1.79	3.91	5.47	7.78	9.6	10.85	11.57	12	
							0.06	0.09	0.19	0.3	0.5	0.73	0.99	1.28	1.52	1.7	
							0.07	0.11	0.23	0.36	0.59	0.86	1.17	1.51	1.79	2	
1	25	150-1500	0.25	6.4	0.8	20.3	0.06	0.09	0.19	0.3	0.5	0.73	0.99	1.28	1.52	1.7	
							0.07	0.11	0.23	0.36	0.59	0.86	1.17	1.51	1.79	2	
			0.375	9.5	0.8	20.3	0.09	0.14	0.29	0.47	0.77	1.12	1.52	1.96	2.33	2.6	
							0.11	0.18	0.36	0.57	0.95	1.38	1.87	2.41	2.86	3.2	
							0.13	0.21	0.43	0.68	1.13	1.64	2.22	2.86	3.4	3.8	
							0.16	0.26	0.53	0.85	1.39	2.03	2.74	3.53	4.21	4.7	
			0.5	12.7	0.8	20.3	0.2	0.33	0.68	1.08	1.78	2.59	3.51	4.51	5.38	6	
							0.27	0.44	0.91	1.44	2.37	3.46	4.68	6.02	7.17	8	
							0.34	0.55	1.14	1.8	2.97	4.32	5.85	7.52	8.96	10	
							0.48	1.03	1.79	3.91	5.47	7.78	9.6	10.85	11.57	12	
							0.06	0.09	0.19	0.3	0.5	0.73	0.99	1.28	1.52	1.7	
							0.07	0.11	0.23	0.36	0.59	0.86	1.17	1.51	1.79	2	
1.5	40	150-1500	0.25	6.4	0.8	20.3	0.06	0.09	0.19	0.3	0.5	0.73	0.99	1.28	1.52	1.7	
							0.07	0.12	0.24	0.38	0.62	0.91	1.23	1.58	1.88	2.1	
			0.375	9.5	0.8	20.3	0.09	0.14	0.29	0.47	0.77	1.12	1.52	1.96	2.33	2.6	
							0.11	0.18	0.36	0.57	0.95	1.38	1.87	2.41	2.86	3.2	
							0.13	0.21	0.43	0.68	1.13	1.64	2.22	2.86	3.4	3.8	
							0.16	0.26	0.53	0.85	1.39	2.03	2.74	3.53	4.21	4.7	
			0.5	12.7	0.8	20.3	0.2	0.33	0.68	1.08	1.78	2.59	3.51	4.51	5.38	6	
							0.27	0.44	0.91	1.44	2.37	3.46	4.68	6.02	7.17	8	
							0.34	0.55	1.14	1.8	2.97	4.32	5.85	7.52	8.96	10	
							0.44	0.72	1.48	2.34	3.86	5.62	7.6	9.77	11.65	13	
							0.61	0.99	2.05	3.24	5.34	7.78	10.53	13.53	16.13	18	
							0.75	1.21	2.51	3.96	6.52	9.5	12.87	16.5	19.71	22	
1.25	31.8	0.8	20.3	1	2.15	3.73	8.15	11.4	16.2	20	22.6	24.11	25				
				1.625	41.3	0.8	20.3	1.4	3	5.2	11.4	15.97	22.69	28	31.65	33.76	35

Contoured Plug

Direction: FLOW-TO-CLOSE (FTC)
Flow Characteristic: MODIFIED PERCENT

Percent of Travel							10	20	30	40	50	60	70	80	90	100			
F _L							0.53	0.53	0.55	0.63	0.72	0.80	0.80	0.80	0.80	0.80	0.80		
Valve Size		ASME Rating	Orifice Diameter		Travel		Rated C _v												
Inch	mm		Inch	mm	Inch	mm													
2	50	150-1500	0.25	6.4	0.8	20.3	0.06	0.09	0.19	0.3	0.5	0.73	0.99	1.28	1.52	1.7			
							0.07	0.12	0.24	0.38	0.62	0.91	1.23	1.58	1.88	2.1			
			0.375	9.5	0.8	20.3	0.09	0.14	0.29	0.47	0.77	1.12	1.52	1.96	2.33	2.6			
							0.11	0.18	0.36	0.57	0.95	1.38	1.87	2.41	2.86	3.2			
							0.13	0.21	0.43	0.68	1.13	1.64	2.22	2.86	3.4	3.8			
			0.5	12.7	0.8	20.3	0.16	0.26	0.53	0.85	1.39	2.03	2.74	3.53	4.21	4.7			
							0.2	0.33	0.68	1.08	1.78	2.59	3.51	4.51	5.38	6			
			0.812	20.6	0.8	20.3	0.27	0.44	0.91	1.44	2.37	3.46	4.68	6.02	7.17	8			
							0.34	0.55	1.14	1.8	2.97	4.32	5.85	7.52	8.96	10			
							0.51	0.83	1.71	2.7	4.45	6.48	8.77	11.28	13.44	15			
			0.994	25.2	0.8	20.3	0.65	1.05	2.17	3.42	5.64	8.21	11.11	14.28	17	19			
							0.75	1.21	2.51	3.96	6.52	9.5	12.87	16.5	19.71	22			
			1.25	31.8	0.8	20.3	0.88	1.43	2.96	4.68	7.71	11.23	15.2	19.54	23.3	26			
			1.625	41.3	0.8	20.3	1.84	3.96	6.85	15	21	29.82	36.81	41.59	44.37	46			
			3	80	150-1500	0.994	25.2	1.5	38.1	0.68	1.1	2.28	3.6	5.93	8.64	11.7	15	17.92	20
										0.91	1.48	3.07	4.86	8	11.67	15.79	20.29	24.2	27
1.25	31.8	1.5				38.1	1.05	1.7	3.53	5.58	9.19	13.4	18.13	23.3	27.78	31			
							1.36	2.2	4.56	7.2	11.86	17.28	23.4	30.07	35.84	40			
1.625	41.3	1.5				38.1	1.6	2.59	5.36	8.46	13.94	20.31	27.49	35.33	42.12	47			
							1.98	3.19	6.61	10.44	17.2	25.07	33.92	43.6	51.98	58			
2	50.8	1.5				38.1	2.45	3.96	8.21	12.96	21.36	31.11	42.11	54.12	64.53	72			
							2.85	4.62	9.57	15.12	24.91	36.29	49.13	63.13	75.28	84			
2.625	66.7	1.5				38.1	4.4	9.46	16.39	35.86	50.18	71.3	88	99.46	106.1	110			
							0.994	25.2	1.5	38.1	0.68	1.1	2.28	3.6	5.93	8.64	11.7	15	17.92
4	100	150-1500	1.25	31.8	1.5	38.1	0.91	1.48	3.07	4.86	8	11.67	15.79	20.29	24.2	27			
							1.36	2.2	4.56	7.2	11.86	17.28	23.4	30.07	35.84	40			
			1.625	41.3	1.5	38.1	1.67	2.7	5.59	8.82	14.53	21.17	28.66	36.83	43.91	49			
							1.98	3.19	6.61	10.44	17.2	25.07	33.92	43.6	51.98	58			
			2	50.8	1.5	38.1	2.52	4.07	8.43	13.32	21.95	31.98	43.28	55.63	66.32	74			
							2.85	4.62	9.57	15.12	24.91	36.29	49.13	63.13	75.28	84			
			2.625	66.7	1.5	38.1	3.84	6.22	12.88	20.34	33.52	48.83	66.94	84.94	101.27	113			
							4.14	6.71	13.9	21.96	36.18	52.71	71.36	91.69	109.34	122			
							4.76	7.7	15.96	25.2	41.52	60.5	81.89	105.24	125.47	140			
			3.5	88.9	1.5	38.1	6.02	9.74	20.18	31.86	52.5	76.48	103.53	133.05	158.63	177			
7.8	16.77	29.1					63.57	88.96	126.4	156.04	176.32	188.08	195						
6	150	150-600	2	50.8	2	50.8	2.75	4.46	9.23	14.58	24.02	35	47.38	60.89	72.59	81			
			2.625	66.7	2	50.8	4.28	6.93	14.36	22.68	37.37	54.44	73.7	94.71	113	126			
			3.5	88.9	2	50.8	7.07	11.44	23.71	37.44	61.69	89.88	121.66	156.35	186	208			
			4.375	111	2	50.8	10.2	16.5	34.2	54	88.98	129.63	175.47	225.51	269	300			
			5	127	2	50.8	16	34.4	59.6	130.4	182.48	259.28	320.1	361.68	386	400			

C_v and F_L Versus Travel

Direction: FLOW-TO-OPEN (FTO)
Flow Characteristic: LINEAR
Rating: ASME 2500 (PN 420)

Contoured Plug

							Percent of Travel										
							10	20	30	40	50	60	70	80	90	100	
							F _L	0.93	0.93	0.92	0.92	0.91	0.91	0.91	0.9	0.9	0.90
Valve Size		ASME Rating	Orifice Diameter		Travel		Rated C _v										
Inch	mm		Inch	mm	Inch	mm											
0.75 ⁽¹⁾	20	2500	0.25	6.4	0.8	20.3	0.15	0.31	0.46	0.61	0.77	0.94	1.12	1.31	1.5	1.7	
			0.375	9.5	0.8	20.3	0.34	0.68	1.02	1.36	1.7	2.11	2.5	2.9	3.4	3.8	
			0.5	12.7	0.8	20.3	0.54	1.07	1.60	2.2	2.7	3.33	4	4.6	5.30	6	
			0.812	20.6	0.8	20.3	0.70	1.40	2.20	2.80	3.60	4.40	5.30	6.20	7.00	8	
1 ⁽¹⁾	25	2500	0.25	6.4	0.8	20.3	0.15	0.31	0.46	0.61	0.77	0.94	1.12	1.31	1.50	1.7	
			0.375	9.5	0.8	20.3	0.34	0.68	1.02	1.36	1.73	2.11	2.5	2.9	3.4	3.8	
			0.5	12.7	0.8	20.3	0.54	1.08	1.61	2.2	2.7	3.33	4.0	4.6	5.3	6	
			0.812	20.6	0.8	20.3	0.9	1.8	2.7	3.6	4.5	5.6	6.6	7.7	9	10	
1.5	40	2500	0.25	6.4	0.8	20.3	0.15	0.31	0.46	0.61	0.77	0.94	1.12	1.31	1.50	1.7	
			0.375	9.5	0.8	20.3	0.34	0.68	1.02	1.36	1.7	2.11	2.5	2.93	3.4	3.8	
			0.5	12.7	0.8	20.3	0.54	1.08	1.61	2.15	2.7	3.33	4.0	4.6	5.3	6	
			0.812	20.6	0.8	20.3	1.18	2.3	3.5	4.7	5.9	7.2	8.6	10	11.5	13	
			0.994	25.2	0.8	20.3	2.1	4.2	6.1	7.9	9.9	11.7	13.7	15.4	16.7	18	
			1.25	31.8	0.8	20.3	2.3	4.5	6.7	9.0	11.3	13.9	16.5	19.3	22.1	25	
			1.625	41.3	0.8	20.3	3.2	6.3	9.4	12.6	15.9	19.4	23.1	27	31	35	
2	50	2500	0.25	6.4	0.8	20.3	0.15	0.31	0.46	0.61	0.77	0.94	1.12	1.31	1.50	1.7	
			0.375	9.5	0.8	20.3	0.34	0.68	1.02	1.36	1.7	2.11	2.5	2.9	3.4	3.8	
			0.5	12.7	0.8	20.3	0.54	1.08	1.61	2.2	2.7	3.33	4.0	4.6	5.3	6	
			0.812	20.6	0.8	20.3	1.4	2.7	4.0	5.4	6.8	8.3	9.9	11.6	13.3	15	
			0.994	25.2	0.8	20.3	2.2	4.4	6.4	8.4	10.4	12.3	14.4	16.3	17.6	19	
			1.25	31.8	0.8	20.3	2.4	4.7	7.0	9.3	11.8	14.4	17.2	20.1	23	26	
			1.625	41.3	0.8	20.3	3.2	6.3	9	12	16	19	23	27	31	35	

1. Close clearance 0.75 and 1 are available in quick change trim only (Model 21114).
2. Models 21614 and 21615 available only in C_v ranges as indicated by green background.

C_v and F_L Versus Travel

Direction: FLOW-TO-OPEN (FTO)
 Flow Characteristic: EQUAL PERCENT
 Rating: ASME 2500 (PN 420)

Contoured Plug

Percent of Travel							10	20	30	40	50	60	70	80	90	100	
F _L							0.93	0.93	0.93	0.93	0.93	0.92	0.92	0.91	0.91	0.91	0.90
Valve Size		ASME Rating	Orifice Diameter		Travel		Rated C _v										
Inch	mm		Inch	mm	Inch	mm											
0.75 ⁽¹⁾	20	2500	0.25	6.4	0.8	20.3	0.05	0.08	0.11	0.18	0.3	0.5	0.8	1.1	1.5	1.7	
			0.375	9.5	0.8	20.3	0.12	0.17	0.24	0.39	0.68	1.13	1.76	2.5	3.26	3.8	
			0.5	12.7	0.8	20.3	0.18	0.27	0.38	0.62	1.07	1.79	2.77	3.95	5.14	6	
			0.812	20.6	0.8	20.3	0.29	0.41	0.56	0.9	1.5	2.9	4.5	6	7	8	
1 ⁽¹⁾	25	2500	0.25	6.4	0.8	20.3	0.05	0.08	0.11	0.18	0.3	0.5	0.8	1.1	1.5	1.7	
			0.375	9.5	0.8	20.3	0.12	0.17	0.24	0.39	0.68	1.13	1.76	2.5	3.26	3.8	
			0.5	12.7	0.8	20.3	0.18	0.27	0.38	0.62	1.07	1.79	2.77	3.95	5.14	6	
			0.812	20.6	0.8	20.3	0.36	0.51	0.7	1.1	1.9	3.6	5.6	7.4	9	10	
1.5	40	2500	0.25	6.4	0.8	20.3	0.05	0.08	0.11	0.18	0.3	0.5	0.8	1.1	1.5	1.7	
			0.375	9.5	0.8	20.3	0.12	0.17	0.24	0.39	0.68	1.13	1.76	2.5	3.26	3.8	
			0.5	12.7	0.8	20.3	0.18	0.27	0.38	0.62	1.07	1.79	2.77	3.95	5.14	6	
			0.812	20.6	0.8	20.3	0.4	0.59	0.82	1.34	2.32	3.87	6.01	8.57	11.1	13	
			0.994	25.2	0.8	20.3	0.43	0.73	1.14	1.73	2.69	4.61	6.93	10.76	14.84	18	
			1.25	31.8	0.8	20.3	0.72	1.02	1.4	2.2	3.8	7.2	11	15	18	20	
			1.625	41.3	0.8	20.3	0.9	1.28	1.76	2.8	4.7	9	14	19	22	25	
2	50	2500	0.25	6.4	0.8	20.3	0.05	0.08	0.11	0.18	0.3	0.5	0.8	1.1	1.5	1.7	
			0.375	9.5	0.8	20.3	0.12	0.17	0.24	0.39	0.68	1.13	1.76	2.5	3.26	3.8	
			0.5	12.7	0.8	20.3	0.18	0.27	0.38	0.62	1.07	1.79	2.77	3.95	5.14	6	
			0.812	20.6	0.8	20.3	0.46	0.68	0.95	1.55	2.68	4.47	6.93	9.88	12.9	15	
			0.994	25.2	0.8	20.3	0.46	0.77	1.2	1.82	2.84	4.87	7.32	11.36	15.67	19	
			1.25	31.8	0.8	20.3	0.8	1.17	1.64	2.68	4.64	7.75	12	17.1	22.3	26	
			1.625	41.3	0.8	20.3	1.3	1.8	2.5	3.9	6.6	13	20	26	31	35	

1. Close clearance 0.75 and 1 inch are available in quick change trim only (Model 21114).
 2. Models 21614 and 21615 available only in C_v ranges as indicated by green background.

C_v and F_L Versus Travel

Direction: FLOW-TO-OPEN (FTO)
 Flow Characteristic: MODIFIED PERCENT
 Rating: ASME 2500 (PN 420)

Contoured Trim

Percent of Travel							10	20	30	40	50	60	70	80	90	100
F _L							0.93	0.93	0.93	0.93	0.93	0.92	0.92	0.91	0.91	0.90
Valve Size		ASME Rating	Orifice Diameter		Travel		Rated C _v									
Inch	mm		Inch	mm	Inch	mm										
0.75 ⁽²⁾	20	2500	0.25	6.4	0.8	20.3	0.04	0.07	0.14	0.28	0.5	0.73	0.99	1.28	1.52	1.7
			0.375	9.5	0.8	20.3	0.09	0.15	0.31	0.64	1.13	1.64	2.22	2.86	3.4	3.8
			0.5	12.7	0.8	20.3	0.14	0.24	0.49	1	1.78	2.59	3.5	4.5	5.38	6
			0.812	20.6	0.8	20.3	0.21	0.49	0.87	2.17	3.65	5.19	6.4	7.23	7.71	8
1 ⁽²⁾	25	2500	0.25	6.4	0.8	20.3	0.04	0.07	0.14	0.28	0.5	0.73	0.99	1.28	1.52	1.7
			0.375	9.5	0.8	20.3	0.09	0.15	0.31	0.64	1.13	1.64	2.22	2.86	3.4	3.8
			0.5	12.7	0.8	20.3	0.14	0.24	0.49	1	1.78	2.59	3.5	4.5	5.38	6
			0.812	20.6	0.8	20.3	0.26	0.58	1.06	2.71	4.56	6.48	8.0	9.04	9.64	10
1.5	40	2500	0.25	6.4	0.8	20.3	0.04	0.07	0.14	0.28	0.5	0.73	0.99	1.28	1.52	1.7
			0.375	9.5	0.8	20.3	0.09	0.15	0.31	0.64	1.13	1.64	2.22	2.86	3.4	3.8
			0.5	12.7	0.8	20.3	0.14	0.24	0.49	1	1.78	2.59	3.5	4.5	5.38	6
			0.812	20.6	0.8	20.3	0.29	0.52	1.07	2.18	3.86	5.62	7.6	9.77	11.65	13
			0.994	25.2	0.8	20.3	0.41	0.71	1.48	3.01	5.34	7.78	10.53	13.53	16.13	18
			1.25	31.8	0.8	20.3	0.68	1.55	2.66	6.77	11.4	16.2	20	22.6	24.11	25
2 ⁽¹⁾	50	2500	0.25	6.4	0.8	20.3	0.04	0.07	0.14	0.28	0.5	0.73	0.99	1.28	1.52	1.7
			0.375	9.5	0.8	20.3	0.09	0.15	0.31	0.64	1.13	1.64	2.22	2.86	3.4	3.8
			0.5	12.7	0.8	20.3	0.14	0.24	0.49	1	1.78	2.59	3.5	4.5	5.38	6
			0.812	20.6	0.8	20.3	0.34	0.59	1.23	2.51	4.45	6.48	8.77	11.28	13.44	15
			0.994	25.2	0.8	20.3	0.43	0.75	1.56	3.18	5.64	8.21	11.11	14.28	17	19
			1.25	31.8	0.8	20.3	0.59	1.03	2.14	4.35	7.71	11.23	15.2	19.54	23.3	26

1. 2 inch size valve with 2 inch (50.8 mm) orifice diameter is only available with quick change trim for ASME Class 150 to 600.
 2. The .75 and 1 inch valves with C_v 8 is available in quick change trim only.

C_v and F_L Versus Travel

Single Stage Lo-dB and Anti-Cavitation Trim
Single Stage Cavitation Containment

Direction: FLOW-TO-OPEN (FTO) Lo-dB
FLOW-TO-CLOSE (FTC) ANTI/CAV
Flow Characteristic: LINEAR

Percent of Travel							10	20	30	40	50	60	70	80	90	100	
F _L							0.93	0.93	0.93	0.93	0.93	0.93	0.93	0.93	0.93	0.93	0.93
Valve Size		ASME Rating	Orifice Diameter		Travel		Rated C _v										
Inch	mm		Inch	mm	Inch	mm											
0.75 ⁽²⁾	20	150-2500	0.812	20.26	0.8	20.3	0.3 ⁽⁴⁾	0.4	0.5	0.7	0.9	1.1	1.3	1.5	1.8	2 ⁽³⁾	
							0.3 ⁽⁴⁾	0.5	0.8	1.1	1.4	1.7	2	2.3	2.6	3 ⁽³⁾	
							0.3 ⁽⁴⁾	0.56	0.96	1.44	2.08	2.68	3.2	3.56	3.84	4	
							0.4	1	1.5	2	2.6	3.1	3.7	4.2	4.7	5	
							0.4	1.1	1.8	2.3	3	3.6	4.2	4.9	5.5	6.2	
							0.48	1.12	1.92	2.88	4.16	5.36	6.4	7.12	7.68	8 ⁽²⁾	
1 ⁽²⁾	25	150-2500	0.812	20.26	0.8	20.3	0.3 ⁽⁴⁾	0.4	0.5	0.7	0.9	1.1	1.3	1.5	1.8	2 ⁽³⁾	
							0.3 ⁽⁴⁾	0.5	0.8	1.1	1.4	1.7	2	2.3	2.6	3 ⁽³⁾	
							0.3 ⁽⁴⁾	0.56	0.96	1.44	2.08	2.68	3.2	3.56	3.84	4	
							0.4	1	1.5	2	2.6	3.1	3.7	4.2	4.7	5	
							0.4	1.1	1.8	2.3	3	3.6	4.2	4.9	5.5	6.2	
							0.48	1.12	1.92	2.88	4.16	5.36	6.4	7.12	7.68	8 ⁽²⁾	
1.5	40	150-2500	0.812	20.26	0.8	20.3	0.3 ⁽⁴⁾	0.56	0.96	1.44	2.08	2.68	3.2	3.56	3.84	4	
							0.4	1	1.5	2.1	2.7	3.3	3.8	4.4	4.8	5	
							0.4	1.1	1.8	2.3	3	3.6	4.2	4.9	5.5	6.2	
			1.25	31.8	0.8	20.3	0.48	1.12	1.92	2.88	4.16	5.36	6.4	7.12	7.68	8	
							0.8	1.8	2.8	3.8	4.9	6	7	8	9	10	
							1	2.2	3.4	4.7	6	7.2	8.4	9.6	10.8	12	
2	50	150-2500	0.812	20.26	0.8	20.3	0.9	2.1	3.6	5.4	7.8	10.1	12	13.4	14.4	15	
							0.24 ⁽⁴⁾	0.56	0.96	1.44	2.08	2.68	3.2	3.56	3.84	4	
							0.4	1	1.5	2.1	2.7	3.3	3.8	4.4	4.8	5	
			1.25	31.8	0.8	20.3	0.4	1.1	1.8	2.3	3	3.6	4.2	4.9	5.5	6.2	
							0.48	1.12	1.92	2.88	4.16	5.36	6.4	7.12	7.68	8	
							0.8	1.8	2.8	3.8	4.9	6	7	8	9	10	
1.625	41.3	0.8	20.3	1	2.2	3.4	4.7	6	7.2	8.4	9.6	10.8	12				
				0.9	2.1	3.6	5.4	7.8	10.1	12	13.4	14.4	15				
				1.5	3	5	7	8.8	10.6	12.4	14.4	16.2	18				
3	80	150-1500	1.625	41.3	1.5	38.1	1.5	3.5	6	9	13	16.8	20	22.3	24	25	
							1.8	4.2	7.2	10.8	15.6	20.2	24	26.8	28.8	30 ⁽¹⁾	
							2	4.7	7.4	10	12.6	15.2	17.8	20.4	23	25	
			2	50.8	1.5	38.1	1.8	4.2	7.2	10.8	15.6	20.2	24	26.8	28.8	30	
							3	6.6	10.3	13.9	17.5	21.1	24.7	28.2	31.7	35	
							4	8	12	16	20	24	28	32	36	40	
2.625	66.7	1.5	38.1	2.9	6.7	11.5	17.3	24.9	32.2	38.4	42.7	46.1	48				
				4.8	10.6	16.4	22	28	33	39	44	49	54				
				5.6	12.3	19.1	25.6	32.2	38.5	44.8	50.7	56.6	63				
				4.5	10.5	18	27	39	50.3	60	66.8	72	75				

1. 2 inch size valve with 2 inch (50.8 mm) orifice diameter is only available with quick change trim for ASME Class 150 to 600.
2. The .75 and 1 inch valves with C_v 8 is available in quick change trim only.
3. 0.75 and 1 inch valve of C_v-2 and 3 are available in ASME Class 150 through 600 only.
4. Throttling at less than minimum operable C_v levels for extended period of time can result in trim damage.

C_v and F_L Versus Travel

Single Stage Lo-dB and Anti-Cavitation Trim Single Stage Cavitation Containment

Direction: FLOW-TO-OPEN (FTO) Lo-dB
 FLOW-TO-CLOSE (FTC) ANTI/CAV
 Flow Characteristic: LINEAR

Valve Size		ASME Rating	Orifice Diameter		Travel		Percent of Travel												
Inch	mm		Inch	mm	Inch	mm	F _L												
								Rated C _v											
								10	20	30	40	50	60	70	80	90	100		
								0.93	0.93	0.93	0.93	0.93	0.93	0.93	0.93	0.93	0.93		
4	100	150-1500	2	50.8	1.5	38.1	1.3	2.9	4.5	6	7.6	9.2	10.7	12.3	13.9	15			
							1.6	3.5	5.5	7.4	9.4	11.3	13.2	15.2	17.1	21			
							2	4.7	7.4	10	12.6	15.2	17.8	20.4	23	25			
			2.625	66.7	1.5	38.1	1.8	4.2	7.2	10.8	15.6	20.2	24	26.8	28.8	30			
							3	6.6	10.3	13.9	17.5	21.1	24.7	28.2	31.7	35			
							4	8	12	16	20	24	28	32	36	40			
							4	8.8	13.7	18.5	23.4	28.2	33	37.7	42.5	48			
							3.8	8.8	15.1	22.7	32.8	42.2	50.4	56.1	60.5	63			
							6.4	14.1	21.9	29.6	37.3	44.8	52.3	59.7	67	75			
			3.5	88.9	1.5	38.1	7.2	15.9	24.7	33.2	41.8	50.2	58.6	66.8	74.8	84			
							6	14	24	36	52	67	80	89	96	100			
6	150	150-600	2.625	66.7	2	50.4	5	11	17	23	29	35	41	47	53	58			
							6	13.5	20.6	28	35	42	49	56	63	70			
							8	16	24	32	41	50	58	66	74	83			
			5	127	2	50.4	8.9	19.5	29.7	40	50.5	60.6	70.8	81.1	91.1	100			
							11.1	24.3	37.1	49.9	63	75.6	88.2	101	113.3	125			
							9	21	36	54	78	101	120	134	144	150			
							15	34	52	70	88	105	122	140	156	172			
							12	28	48	72	104	134	160	178	192	200			
			8	200	150-600	5	127	2.5	63.5	18.5	39.6	60.8	81.7	102.5	122.9	143.1	163.4	183.6	200
										22.6	48.4	74.1	99.7	124.8	149.5	173.9	198.2	222.2	240
										6.25	157.8	2.5	63.5	18	31	65	98	120	161

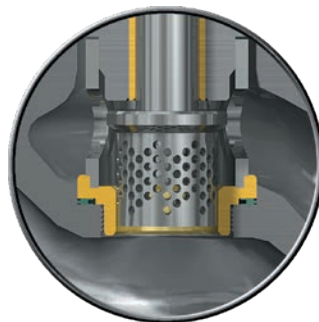

Single Stage Lo-dB and Anti-Cavitation Trim

C_v and F_L Versus Travel

Single Stage Lo-dB and Anti-Cavitation Trim Single Stage Cavitation Containment

Direction: FLOW-TO-OPEN (FTO) Lo-dB
FLOW-TO-CLOSE (FTC) ANTI/CAV
Flow Characteristic: EQUAL PERCENT

Percent of Travel							10	20	30	40	50	60	70	80	90	100	
F _L							0.93	0.93	0.93	0.93	0.93	0.93	0.93	0.93	0.93	0.93	0.93
Valve Size		ASME Rating	Orifice Diameter		Travel		Rated C _v										
Inch	mm		Inch	mm	Inch	mm											
0.75	20	150-2500	8.12	20.26	0.8	20.3	0.17 ⁽²⁾	0.2	0.26	0.38	0.5	0.64	0.96	1.3	1.66	2	
							0.19 ⁽²⁾	0.21	0.32	0.45	0.82	1.3	1.78	2.36	2.7	3	
							0.22 ⁽²⁾	0.29	0.42	0.56	0.7	1.01	1.42	2.12	3.04	3.8	
							0.22 ⁽²⁾	0.3	0.47	0.89	1.46	2.14	2.87	3.63	4.32	5	
1	25	150-2500	8.12	20.26	0.8	20.3	0.17 ⁽²⁾	0.2	0.26	0.38	0.5	0.64	0.96	1.3	1.66	2	
							0.19 ⁽²⁾	0.21	0.32	0.45	0.82	1.3	1.78	2.36	2.7	3	
							0.22 ⁽²⁾	0.29	0.42	0.56	0.7	1.01	1.42	2.12	3.04	3.8	
							0.22 ⁽²⁾	0.3	0.47	0.89	1.46	2.14	2.87	3.63	4.32	5	
1.5	40	150-2500	8.12	20.26	0.8	20.3	0.17 ⁽²⁾	0.29	0.42	0.56	0.7	1.01	1.42	2.12	3.04	3.8	
							0.32 ⁽²⁾	0.4	0.5	0.89	1.46	2.14	2.87	3.63	4.32	5	
			1.25	31.8	0.8	20.3	0.35 ⁽²⁾	0.48	0.73	1.2	1.71	2.46	3.38	4.3	5.16	6	
							0.38 ⁽²⁾	0.63	1	1.3	1.9	3	4.5	6.1	7.6	9	
			1.625	41.28	0.8	20.3	0.40 ⁽²⁾	0.66	1.2	2	3.2	4.4	6.1	7.8	9.3	11	
							0.58 ⁽²⁾	0.78	1.2	1.8	2.3	4.1	6.3	8.7	10.9	13	
2	50	150-2500	0.812	20.26	0.8	20.3	0.64 ⁽²⁾	0.9	1.4	2	3	4.7	7.4	10	12.5	15	
							0.17 ⁽²⁾	0.29	0.42	0.56	0.7	1.01	1.42	2.12	3.04	3.8	
			1.25	31.8	0.8	20.3	0.32 ⁽²⁾	0.4	0.5	0.89	1.46	2.14	2.87	3.63	4.32	5	
							0.35 ⁽²⁾	0.48	0.73	1.2	1.71	2.46	3.38	4.3	5.16	6	
			1.625	41.28	0.8	20.3	0.38 ⁽²⁾	0.63	1	1.3	1.9	3	4.5	6.1	7.6	9	
							0.40 ⁽²⁾	0.66	1.2	2	3.2	4.4	6.1	7.8	9.3	11	
2	50.8	0.8	20.3	0.58 ⁽²⁾	0.78	1.2	1.8	2.3	4.1	6.3	8.7	10.9	13				
				0.64 ⁽²⁾	0.9	1.4	2	3	4.7	7.4	10	12.5	15				
3	80	150-1500	2.625	66.7	1.5	31.8	0.77 ⁽²⁾	1.1	1.5	2.3	3.6	5.7	8.8	12	15	18 ⁽¹⁾	
							0.86	1.26	1.7	2.7	4.3	7.5	11	14.6	17.5	21 ⁽¹⁾	
			1.26 ⁽²⁾	1.47	1.9	2.7	3.9	6.3	9.5	13	17	21					
													1.34 ⁽²⁾	1.49	2.2	3.2	4.7
			1.46 ⁽²⁾	1.7	2.6	4	6.6	10	16	22	28	33					
													1.6	4	6.5	8.5	11
1.7	2.8	4.2	8.5	16	22	28	34	41	47								
										1.9	3.3	6.6	11	18	26	34	41
4	100	150-1500	2.625	66.7	1.5	31.8	1.26 ⁽²⁾	1.47	1.9	2.7	3.9	6.3	9.5	13	17	21	
							1.34 ⁽²⁾	1.49	2.2	3.2	4.7	7.8	12.4	16.8	22	27	
			1.46 ⁽²⁾	1.7	2.6	4	6.6	10	16	22	28	33					
													1.64	4	6.5	8.5	11
			1.7	2.8	4.2	8.5	16	22	28	34	41	47					
													1.9	3.3	6.6	11	18
3.5	88.9	1.5	31.8	2.6 ⁽²⁾	4	8	14	25	34	44	55	65	75				

1. 2 inch size valve with 2 inch (50.8 mm) orifice diameter is only available with quick change trim for ASME Class 150 to 600.
2. Throttling at less than minimum operable C_v levels for extended period of time can result in trim damage.

C_v and F_L Versus Travel

Double Stage Anti-Cavitation Trim⁽¹⁾

Direction: FLOW-TO-CLOSE (FTC)
Flow Characteristic: LINEAR

Percent of Travel							10	20	30	40	50	60	70	80	90	100				
F _L							0.975	0.975	0.975	0.975	0.975	0.975	0.975	0.975	0.975	0.975	0.975			
Valve Size		ASME Rating	Orifice Diameter		Travel		Rated C _v													
inch	mm		inch	mm	inch	mm														
0.75	20	150-2500	0.812	20.26	0.8	20.3	0.24 ⁽³⁾	0.32	0.55	0.83	1.2	1.54	1.84	2.05	2.21	2.3				
							0.3 ⁽³⁾	0.6	0.8	1.1	1.4	1.7	2	2.2	2.5	2.8				
							0.3 ⁽³⁾	0.6	0.9	1.3	1.7	2	2.4	2.7	3	3.4				
							0.27 ⁽³⁾	0.63	1.08	1.62	2.34	3.02	3.6	4.01	4.3	4.5				
1	25	150-2500	0.812	20.26	0.8	20.3	0.24 ⁽³⁾	0.32	0.55	0.83	1.2	1.54	1.84	2.05	2.21	2.3				
							0.3 ⁽³⁾	0.6	0.8	1.1	1.4	1.7	2	2.2	2.5	2.8				
							0.3 ⁽³⁾	0.6	0.9	1.3	1.7	2	2.4	2.7	3	3.4				
							0.27	0.63	1.08	1.62	2.34	3.02	3.6	4.01	4.3	4.5				
1.5	40	150-2500	0.812	20.26	0.8	20.3	0.14 ⁽³⁾	0.32	0.55	0.83	1.2	1.54	1.84	2.05	2.21	2.3				
							0.2 ⁽³⁾	0.3	0.6	0.9	1.1	1.4	1.8	2.2	2.5	2.8				
							0.3 ⁽³⁾	0.7	1	1.4	1.7	2	2.4	2.7	3.1	3.4				
							0.37	0.63	1.08	1.62	2.34	3.02	3.6	4.01	4.3	4.5				
			1.25	31.8	0.8	20.3	0.4	0.9	1.5	2.1	2.7	3.3	3.9	4.5	5.1	5.6				
							0.5	1.1	1.8	2.5	3.2	4	4.8	5.4	6	6.8				
							0.51	1.19	2.04	3.06	4.42	5.7	6.8	7.57	8.16	8.5				
							0.5	1.6	2.7	3.8	4.9	5.9	7	8	9	10				
2	50	150-2500	0.812	20.26	0.8	20.3	0.2 ⁽³⁾	0.3	0.6	0.9	1.1	1.4	1.8	2.2	2.5	2.8				
							0.3 ⁽³⁾	0.7	1	1.4	1.7	2	2.4	2.7	3.1	3.4				
							0.37	0.63	1.08	1.62	2.34	3.02	3.6	4.01	4.3	4.5				
							0.4	0.9	1.5	2.1	2.7	3.3	3.9	4.5	5.1	5.6				
			1.25	31.8	0.8	20.3	0.5	1.1	1.8	2.5	3.2	4	4.8	5.4	6	6.8				
							0.51	1.19	2	3.06	4.42	5.7	6.8	7.57	8.16	8.5				
							1.625	41.3	1.5	38.1	0.5	1.6	2.7	3.8	4.9	5.9	7	8	9	10
							2	50.8	0.8	20.23	0.8	1.9	3.4	5	7.3	9.4	11.2	12.5	13.4	14
3	80	150-1500	1.625	41.3	1.5	38.1	1.7	3.4	5.1	6.8	8.5	10.2	11.9	13.6	15.3	17 ⁽²⁾				
							0.4	1.4	2.6	3.8	4.9	6	7.2	8.4	9.6	11				
							0.8	1.9	3.5	5	6.5	8	9.5	11	12.5	14				
							1.7	3.4	5.1	6.8	8.5	10.2	11.9	13.6	15.3	17				
			2	50.8	1.5	38.1	2.2	4.4	6.6	8.8	11	13.2	15.4	17.6	19.8	22				
							1.6	3.8	6.4	9.7	14.1	18.1	21.6	24	25.9	27				
							2.5	5.9	10.1	15.1	21.8	28.1	33.6	37.4	40.3	42				
							2.2	4.4	6.6	8.8	11	13.2	15.4	17.6	19.8	22				
2.625	66.7	1.5	38.1	1.8	4.6	7.5	10.5	13.2	16	18.7	21.4	24.1	27							
				2.4	5.6	9.6	14.4	20.8	26.8	32	35.6	38.4	40							
				5	10	15	20	25	30	35	40	45	50							
				3.7	8.7	14.9	22.3	32.2	41.5	49.6	55.2	59.5	62							

1. Double stage anti-cavitation trim not available with Bellows Seal construction.
2. 2 inch size valve with 2 inch (50.8 mm) orifice diameter is only available with quick change trim for ASME Class 150 to 600.
3. Throttling at less than minimum operable C_v levels for extended period of time can result in trim damage.

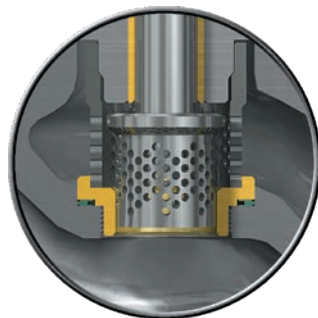

Double Stage Lo-dB and Anti-Cavitation Trim

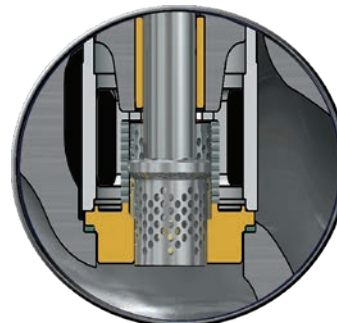

Double Stage Seat Extension Trim

C_v and F_L Versus Travel

Double Stage Lo-dB Trim⁽¹⁾

Direction: FLOW-TO-OPEN (FTO)
Flow Characteristic: LINEAR

Percent of Travel							10	20	30	40	50	60	70	80	90	100			
F _L							0.95	0.95	0.95	0.95	0.95	0.95	0.95	0.95	0.95	0.95	0.95		
Valve Size		ASME Rating	Orifice Diameter		Travel		Rated C _v												
inch	mm		inch	mm	inch	mm													
0.75	20	150-2500	0.812	20.6	0.8	20.3	0.24 ⁽³⁾	0.49	0.84	1.26	1.82	2.35	2.8	3.12	3.36	3.5			
							0.3 ⁽³⁾	0.8	1.2	1.7	2.2	2.6	3	3.5	4	4.2			
							0.34	0.8	1.37	2.05	2.96	3.82	4.56	5.07	5.47	5.7			
1	25	150-2500	0.812	20.6	0.8	20.3	0.24 ⁽³⁾	0.49	0.84	1.26	1.82	2.35	2.8	3.12	3.36	3.5			
							0.3 ⁽³⁾	0.8	1.2	1.7	2.2	2.6	3	3.5	4	4.2			
							0.34	0.8	1.37	2.05	2.96	3.82	4.56	5.07	5.47	5.7			
1.5	40	150-2500	0.812	20.6	0.8	20.3	0.24 ⁽³⁾	0.49	0.84	1.26	1.82	2.35	2.8	3.12	3.36	3.5			
							0.3 ⁽³⁾	0.8	1.2	1.7	2.2	2.6	3	3.5	4	4.2			
							0.4	0.9	1.4	2	2.5	3	3.5	4	4.5	5			
			1.25	31.8	0.8	20.3	0.42	0.98	1.68	2.52	3.64	4.69	5.6	6.23	6.72	7			
							0.6	1.5	2.4	3.2	4	4.8	5.6	6.4	7.2	8			
							0.8	1.9	2.9	3.9	5	6	7	8	9	10			
							0.8	1.8	3.1	4.7	6.8	8.7	10.4	11.6	12.5	13			
2	50	150-2500	0.812	20.6	0.8	20.3	0.24 ⁽³⁾	0.49	0.84	1.26	1.82	2.35	2.8	3.12	3.36	3.5			
							0.3 ⁽³⁾	0.8	1.2	1.7	2.2	2.6	3	3.5	4	4.2			
							0.4	0.9	1.4	2	2.5	3	3.5	4	4.5	5			
			1.25	31.8	0.8	20.3	0.42	0.98	1.68	2.52	3.64	4.69	5.6	6.23	6.72	7			
							0.6	1.5	2.4	3.2	4	4.8	5.6	6.4	7.2	8			
							0.8	1.9	2.9	3.9	5	6	7	8	9	10			
							0.8	1.8	3.1	4.7	6.8	8.7	10.4	11.6	12.5	13			
1.625	41.28	0.8	20.3	1	2.7	4.2	5.8	7.4	8.8	10.4	12	13.5	15						
				1.2	3	4.7	6.5	8.3	10	11.6	13.3	15	17						
				1.3	2.9	5	7.6	10.9	14.1	16.8	18.7	20.2	21						
2 ⁽¹⁾	50.8 ⁽¹⁾	0.8	20.3	1.5	4.5	7	9.5	12	14.5	17	19	21.5	24 ⁽²⁾						
3	80	150-1500	1.625	41.28	1.5	38.1	1.1	2.5	3.8	5	6.5	7.7	9	10.4	11.7	13			
							1.3	3	4.6	6.2	7.6	9.5	11.2	12.8	14.5	16			
							1.6	4	6.2	8.4	10.6	12.7	14.8	17	19	21			
			2	50.8	1.5	38.1	1.9	4.6	7	9.5	12	14.5	17	19	21.5	24			
							2	5	7.8	10.5	13.5	16.2	18.9	21.6	24.3	28			
							2.8	6.5	10	13.5	17	20.5	24	27.5	30.5	33			
							2.4	5.6	9.6	14.4	20.8	26.8	32	35.6	38.4	40			
4.4	10	16	21	27	32	38	43	48	53										
										3.8	8.8	15.1	22.7	32.8	42.2	50.4	56.1	60.5	63

1. Double stage anti-cavitation trim not available with Bellows Seal construction.
 2. 2 inch size valve with 2 inch (50.8 mm) orifice diameter is only available with quick change trim for ASME Class 150 to 600.
 3. Throttling at less than minimum operable C_v levels for extended period of time can result in trim damage.

21000 Series Standard Design Materials of Construction

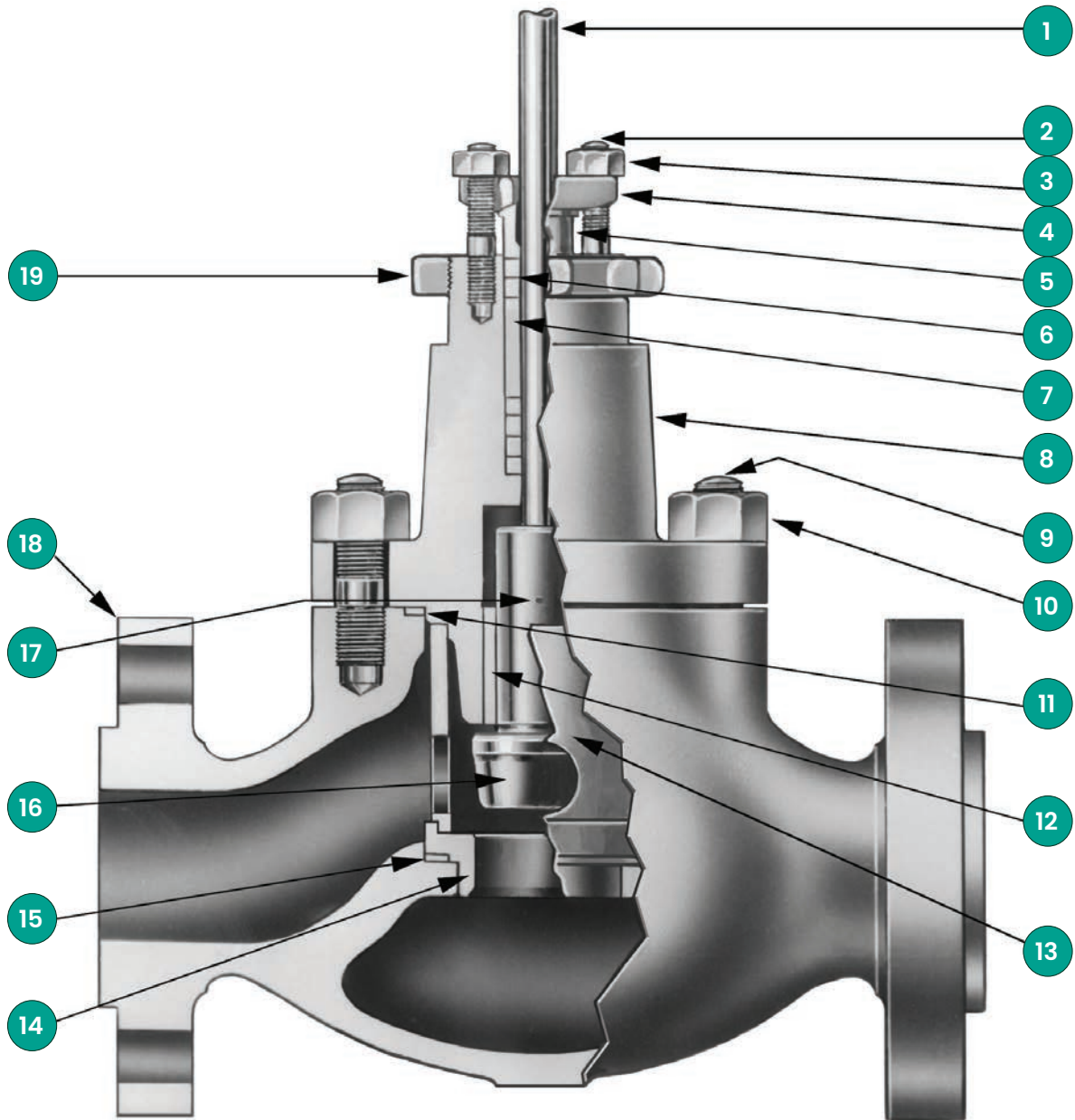

21000 Series - Standard Design

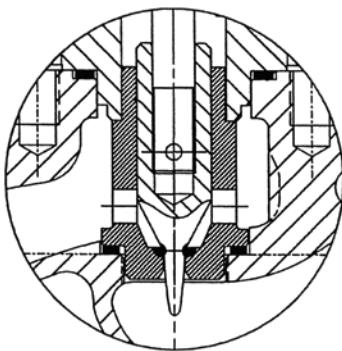

21000 Close Clearance
Low Flow Trim

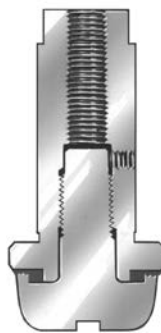

Soft Seated
Plug S/A

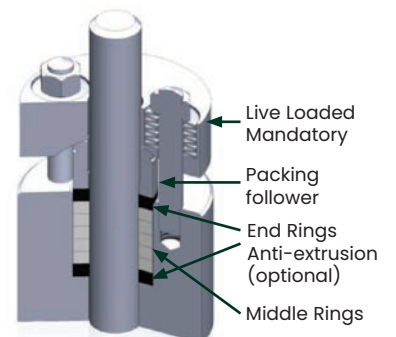

LE Packing System (Optional)
Low Emission Stem Packing

21000 Series Standard Design Materials of Construction

Carbon Steel Version

Ref. No.	Temperature Range	-20°F (-29°C)	450°F (232°C)	650°F (343°C)	800°F (427°C)
	Description	Standard Materials			
1	Plug Stem	17-4 PH STAINLESS STEEL H1075 ⁽¹⁾			
		SOLUTION ANNEALED 316 STAINLESS STEEL			
		HARDENED ASTM A638 GRADE 660			
		ASTM B637 ALLOY			
2	Packing Flange Stud	ASTM A193 GRADE B8 CLASS 1			
3	Packing Flange Nut	ASTM A194 GRADE 8			
4	Packing Flange	LOW CARBON STEEL ZINC PLATED			
5	Packing Follower	SOLUTION ANNEALED 316L STAINLESS STEEL			
6	Packing	PTFE PACKING and LE PACKING		FLEXIBLE GRAPHITE PACKING	
		CARBON CORE BRAIDED PTFE PACKING WITH EXTENSION BONNET			
7	Lantern Ring (Optional)	AUSTENITIC STAINLESS STEEL			
8	Valve Bonnet	ASTM A216 GRADE WCC/WCB/EN 1.0619/1.0625 or A105			
9	Body Stud	ASTM A193 GRADE B7			
10	Body Stud Nut	ASTM A194 GRADE 2H			
11	Body Gasket	316L STAINLESS STEEL SPIRAL WOUND GASKET WITH GRAPHITE FILLER			
12	Guide Bushing ⁽⁶⁾	HARDENED 440C STAINLESS STEEL ⁽²⁾			
		STELLITE OR EQUIVALENT NO. 6			
13	Cage and Retainer ⁽⁴⁾	SOLUTION ANNEALED 304 STAINLESS STEEL			
		CA6NM CLASS B STAINLESS STEEL ⁽³⁾			
	Close Clearance Cage and Seat	SOLUTION ANNEALED 316 STAINLESS STEEL			
HARDENED 410 STAINLESS STEEL					
STELLITE OR EQUIVALENT NO. 6					
14	Seat Ring	SOLUTION ANNEALED 316 STAINLESS STEEL			
		HARDENED 410 STAINLESS STEEL			
		316 STAINLESS STEEL WITH STELLITE OR EQUIVALENT NO. 6 HARDFACING			
		HARDENED 440C STAINLESS STEEL (from 0.75" to 3" only)			
15	Seat Ring Gasket	316L STAINLESS STEEL SPIRAL WOUND GASKET WITH GRAPHITE FILLER			
16	Plug	SOLUTION ANNEALED 316 STAINLESS STEEL			
		SOLUTION ANNEALED 316 SS WITH PTFE SEAT			
		HARDENED 410 STAINLESS STEEL			
		316 STAINLESS STEEL WITH STELLITE OR EQUIVALENT NO. 6 HARDFACING ON SEAT ⁽⁵⁾			
		316 STAINLESS STEEL WITH STELLITE OR EQUIVALENT NO. 6 HARDFACING ON SEAT AND GUIDE ⁽⁵⁾			
	Close Clearance Plug	STELLITE OR EQUIVALENT NO. 6 ⁽⁷⁾			
17	Plug Pin	SOLUTION ANNEALED 316 STAINLESS STEEL			
18	Valve Body	ASTM A216 GRADE WCC/WCB / EN 1.0619/1.0625			
19	Drive Nut	LOW CARBON STEEL GRADES DICHROMATE ZINC PLATED			

1. 17-4 PH ST.ST will be substituted when required due to the differential pressure.

2. 440C bushing not used in combination with 316 trim.

3. Standard material for two stage lo-db (drilled hole) cages.

4. Required for Quick Change trim only.

5. Use Solid Stellite or Equivalent plug for C_v smaller than 1.7.

6. Guide bushings not used with close clearance trim.

7. Solid Stellite or Equivalent is not available for Lo-db and Anti-Cavitation plugs.

21000 Series Standard Design Materials of Construction

Stainless Steel Version

Ref. No.	Temperature Range	-20°F (-29°C)	450°F (232°C)	650°F (343°C)	800°F (427°C)
	Description	Standard Materials			
1	Plug Stem	SOLUTION ANNEALED 316 STAINLESS STEEL			
		HARDENED ASTM A638 GRADE 660			
		ASTM B637 ALLOY			
2	Packing Flange Stud	ASTM A193 GRADE B8 CLASS 1			
3	Packing Flange Nut	ASTM A194 GRADE 8			
4	Packing Flange	ASTM A216 GRADE WCC ZINC PLATING			
5	Packing Follower	AUSTENITIC STAINLESS STEEL			
6	Packing	PTFE PACKING and LE PACKING		FLEXIBLE GRAPHITE PACKING	
		PTFE PACKING and LE PACKING WITH EXTENSION BONNET			
7	Lantern Ring (Optional)	AUSTENITIC STAINLESS STEEL			
8	Valve Bonnet	ASTM A351 GRADE CF8M			
9	Body Stud	ASTM A193 GR B7 – ZINC PLATING		ASTM A193 GRADE B7	
10	Body Stud Nut	ASTM A194 GR 2H – ZINC PLATING		ASTM A194 GRADE 2H	
11	Body Gasket	316L STAINLESS STEEL SPIRAL WOUND GASKET WITH GRAPHITE FILLER			
12	Guide Bushing ⁽⁴⁾	NITRONIC 60 ASTM A479			
		STELLITE OR EQUIVALENT NO. 6			
13	Cage and Retainer ⁽¹⁾	SOLUTION ANNEALED 304 STAINLESS STEEL			
		CA6NM CLASS B STAINLESS STEEL ⁽²⁾			
	Close Clearance Cage and Seat	SOLUTION ANNEALED 316 STAINLESS STEEL			
HARDENED 410 STAINLESS STEEL					
STELLITE OR EQUIVALENT NO. 6					
14	Seat Ring	SOLUTION ANNEALED 316 STAINLESS STEEL			
		316 STAINLESS STEEL WITH STELLITE OR EQUIVALENT NO. 6 HARDFACING			
15	Seat Ring Gasket	316L STAINLESS STEEL SPIRAL WOUND GASKET WITH GRAPHITE FILLER			
16	Plug	SOLUTION ANNEALED 316 STAINLESS STEEL			
		SOLUTION ANNEALED 316 SS WITH PTFE SEAT			
		HARDENED 410 STAINLESS STEEL			
		316 STAINLESS STEEL WITH STELLITE OR EQUIVALENT NO. 6 HARDFACING ON SEAT ⁽³⁾			
		316 STAINLESS STEEL WITH STELLITE OR EQUIVALENT NO. 6 HARDFACING ON SEAT AND GUIDE ⁽³⁾			
	STELLITE OR EQUIVALENT NO. 6 ⁽⁵⁾				
	Close Clearance Plug	STELLITE OR EQUIVALENT NO. 6 ⁽⁵⁾			
17	Plug Pin	SOLUTION ANNEALED 316 STAINLESS STEEL			
18	Valve Body	ASTM A351 GRADE CF8M			
19	Drive Nut	ASTM A216 GRADE WCC			

1. Required for Quick Change trim only.

2. Standard material for two stage lo-dB (drilled hole) cages.

3. Use Solid Stellite or Equivalent plug for C_v smaller than 1.7.

4. Guide bushings not used with close clearance trim.

5. Solid Stellite or Equivalent is not available for Lo-dB and Anti-Cavitation plugs.

21000 Series Standard Design Materials of Construction

Chrome Moly Version

Ref. No.	Temperature Range	-20°F (-29°C)	450°F (232°C)	650°F (343°C)	800°F (427°C)	
		Standard Materials				
1	Plug Stem	17-4 PH STAINLESS STEEL H1075 ⁽¹⁾				
		SOLUTION ANNEALED 316 STAINLESS STEEL				
		HARDENED ASTM A638 GRADE 660				
		ASTM B637 ALLOY				
2	Packing Flange Stud	ASTM A193 GRADE B8 CLASS 1				
3	Packing Flange Nut	ASTM A194 GRADE 8				
4	Packing Flange	ASTM A216 GRADE WCC ZINC PLATING				
5	Packing Follower	AUSTENITIC STAINLESS STEEL				
6	Packing	PTFE PACKING and LE PACKING		FLEXIBLE GRAPHITE PACKING		
		PTFE PACKING and LE PACKING WITH EXTENSION BONNET				
7	Lantern Ring (Optional)	AUSTENITIC STAINLESS STEEL				
8	Valve Bonnet	ASTM A217 GRADE WC9 CLASS 3				
9	Body Stud	ASTM A193 GRADE B7				
10	Body Stud Nut	ASTM A194 GRADE 2H				
11	Body Gasket	316L STAINLESS STEEL SPIRAL WOUND GASKET WITH GRAPHITE FILLER				
12	Guide Bushing ⁽⁵⁾	HARDENED 440C STAINLESS STEEL				
		STELLITE OR EQUIVALENT NO. 6				
13	Cage and Retainer ⁽²⁾	SOLUTION ANNEALED 304 STAINLESS STEEL				
		CA6NM CLASS B STAINLESS STEEL ⁽³⁾				
13	Close Clearance Cage and Seat	SOLUTION ANNEALED 316 STAINLESS STEEL				
		HARDENED 410 STAINLESS STEEL				
		STELLITE OR EQUIVALENT NO. 6				
14	Seat Ring	SOLUTION ANNEALED 316 STAINLESS STEEL				
		HARDENED 410 STAINLESS STEEL				
		316 STAINLESS STEEL WITH STELLITE OR EQUIVALENT NO. 6 HARDFACING				
15	Seat Ring Gasket	316L STAINLESS STEEL SPIRAL WOUND GASKET WITH GRAPHITE FILLER				
16	Plug	SOLUTION ANNEALED 316 STAINLESS STEEL				
		SOLUTION ANNEALED 316 STAINLESS STEEL WITH PTFE SEAT				
		HARDENED 410 STAINLESS STEEL				
		316 STAINLESS STEEL WITH STELLITE OR EQUIVALENT NO. 6 HARDFACING ON SEAT ⁽⁴⁾				
		316 STAINLESS STEEL WITH STELLITE OR EQUIVALENT NO. 6 HARDFACING ON SEAT AND GUIDE ⁽⁴⁾				
	Close Clearance Plug	STELLITE OR EQUIVALENT NO. 6 ⁽⁶⁾				
17	Plug Pin	SOLUTION ANNEALED 316 STAINLESS STEEL				
18	Valve Body	ASTM A217 GRADE WC9 CLASS 3				
19	Drive Nut	ASTM A216 GRADE WCC				

1. 17-4 PH Stainless Steel will be substituted when required due to the differential pressure.

2. Required for Quick Change trim only.

3. Standard material for two stage Lo-db (drilled hole) cages.

4. Use Solid Stellite or Equivalent plug for C_v smaller than 1.7.

5. Guide bushings not used with close clearance trim.

6. Solid Stellite or Equivalent is not available for Lo-db and Anti-Cavitation plugs.

21000 Series Standard Design Materials of Construction

NACE Materials Construction

Ref. No.	Temperature Range	-50°F (-46°C)	-20°F (-29°C)	450°F (232°C)
	Description	NACE Materials ⁽¹⁾		
1	Plug Stem ⁽⁸⁾	SOLUTION ANNEALED 316 STAINLESS STEEL		
		ASTM B637 ALLOY UNS NO7750 ⁽²⁾		
		SOLUTION ANNEALED 316L STAINLESS STEEL		
2	Packing Flange Stud	ASTM A194 GRADE 8		
3	Packing Flange Nut	ASTM A194 GRADE 8		
4	Packing Flange	LOW CARBON STEEL ZINC PLATED		
5	Packing Follower	SOLUTION ANNEALED 316L STAINLESS STEEL		
6	Packing	CARBON CORE BRAIDED PTFE PACKING		
7	Lantern Ring (Optional)	SOLUTION ANNEALED 304 STAINLESS STEEL		
8	Valve Bonnet	ASTM A216 GRADE WCC/WCB/EN 1.0619/1.0625		
		ASTM A105/1.0436 EN 10222-2		
		ASTM A351 GRADE CF8M/EN 1.4408		
9	Body Stud	ASTM A193 GR B7 – ZINC PLATING ^{(3) (7)}		
		ASTM A193 GR B7M ZINC PLATING ^{(4) (7)}		
		ASTM A193 GRADE B7 ⁽³⁾		
		ASTM A193 GRADE B7M ⁽⁴⁾		
10	Body Stud Nut	ASTM A194 GR 2H – ZINC PLATING ^{(3) (7)}		
		ASTM A194 GR 2HM ZINC PLATING ^{(4) (7)}		
		ASTM A194 GRADE 2H ⁽³⁾		
		ASTM A194 GRADE 2HM ⁽⁴⁾		
11	Body Gasket	316L ST ST SPIRAL WOUND GASKET WITH GRAPHITE FILLER		
12	Guide Bushing ⁽⁶⁾	STELLITE OR EQUIVALENT NO. 6		
13	Cage and Retainer ⁽⁴⁾	SOLUTION ANNEALED 304 STAINLESS STEEL		
	Close Clearance Cage and Seat	SOLUTION ANNEALED 316 STAINLESS STEEL STELLITE OR EQUIVALENT NO. 6		
14	Seat Ring	SOLUTION ANNEALED 316 STAINLESS STEEL		
		316 STAINLESS STEEL WITH STELLITE OR EQUIVALENT NO. 6 HARDFACING		
15	Seat Ring Gasket	316L ST ST SPIRAL WOUND GASKET WITH GRAPHITE FILLER		
16	Plug	SOLUTION ANNEALED 316 STAINLESS STEEL		
		316 STAINLESS STEEL WITH STELLITE OR EQUIVALENT NO. 6 HARDFACING ON SEAT		
		316 STAINLESS STEEL WITH STELLITE OR EQUIVALENT NO. 6 HARDFACING ON SEAT AND GUIDE		
	Close Clearance Plug	STELLITE OR EQUIVALENT NO. 6 ^{(6) (9)} STELLITE OR EQUIVALENT NO. 6 ^{(6) (9)}		
17	Plug Pin	SOLUTION ANNEALED 316 STAINLESS STEEL		
18	Valve Body	ASTM A216 GRADE WCC/WCB/EN 1.0619/1.0625		
		ASTM A105/1.0436 EN 10222-2		
		ASTM A351 GRADE CF8M/EN 1.4408		
19	Drive Nut	ASTM A216 GRADE WCC		

1. Materials and processes in accordance with the requirements of NACE specification MR0103. Applications requiring compliance to MR0175, 2003 Rev. or ISO 15156 would require engineering review.
2. Inconel 718 will be substituted in applications when required due to the differential pressure.
3. Materials designated for these parts conform to NACE non-exposed bolting requirements.
4. Materials designated for these parts conform to NACE exposed bolting requirements.

5. Consult Masoneilan for NACE Applications above ANSI Class 600 (PN 100) rating or above 450°F (232°C).
6. Optional component and materials for Close Clearance low flow trim option.
7. To be used with stainless steel body and bonnet.
8. Guide bushing not used with close clearance trim.
9. Solid Stellite or Equivalent is not available for Lo-dB and Anti-Cavitation plugs.

21000 Series Standard Design Materials of Construction

Cryogenic Construction

Ref. No.	Temperature Range	-320°F (-196°C)	-50°F (-46°C)	-20°F (-29°C)
	Description ^{(3),(4)}	Standard Materials ^{(1),(2),(5)}		
1	Plug Stem	SOLUTION ANNEALED 316 STAINLESS STEEL		
		HARDENED ASTM A638 GRADE 660		
2	Packing Flange Stud	ASTM A193 GRADE B8 CLASS 1		
3	Packing Flange Nut	ASTM A194 GR 8		
4	Packing Flange	ASTM A351 GRADE CF8M		
5	Packing Follower	SOLUTION ANNEALED 316L STAINLESS STEEL		
6	Packing	PTFE V-Ring		
7	Lantern Ring (Optional)	AUSTENITIC STAINLESS STEEL		
8	Valve Bonnet	ASTM A351 GRADE CF8M/EN 1.4408		
		ASTM A479 TYPE 316		
		ASTM A312 TYPE 316		
9	Body Stud ⁽⁶⁾	ASTM A193 GRADE B8 CLASS 2 FOR STUDS < Ø 3/4" 0.75" ; 1" ; 1.5" ; 2" AND 3" => 150/300/600 lb 4" ; 6" => 150/300 lb		
		ASTM A453 GRADE 660 CLASS A FOR STUDS > 3/4" 0.75" ; 1" ; 1.5" AND 2" => 900/1500/2500 lb 3" => 900/1500 lb - 4"=>600/900/1500 lb 6" => 600 lb - 8" => 150/300/600 lb		
10	Body Stud Nut	ASTM A194 GR 8		
11	Body Gasket	316L STAINLESS STEEL SPIRAL WOUND GASKET WITH GRAPHITE FILLER		
12	Guide Bushing ⁽⁶⁾	STELLITE NO. 6 (UNS 30006) (STANDARD)		
		ASTM A479 UNS S21800 (OPTIONAL)		
13	Cage	SOLUTION ANNEALED 304 STAINLESS STEEL (STANDARD)		
		SOLUTION ANNEALED 316 STAINLESS STEEL (OPTIONAL)		
		ASTM A479 TYPE 316		
14	Seat Ring	SOLUTION ANNEALED 316 STAINLESS STEEL (STANDARD)		
		HARDFACING STELLITE NO. 6 ON 316 STAINLESS STEEL		
15	Seat Ring Gasket	316L STAINLESS STEEL SPIRAL WOUND GASKET WITH GRAPHITE FILLER		
16	Plug	SOLUTION ANNEALED 316 STAINLESS STEEL (STANDARD)		
		HARDFACING STELLITE NO. 6 ON 316 STAINLESS STEEL		
17	Plug Pin	SOLUTION ANNEALED 316 STAINLESS STEEL		
18	Valve Body	ASTM A351 GRADE CF8M/EN 1.4408		
19	Drive Nut	LOW CARBON STEEL GRADES DICHROMATE ZINC PLATED		

1. Materials recommended for Cryogenic Liquid Natural Gas (LNG) applications -320°F (-196°C). Consult factory for suitability in other cryogenic applications.

2. Consult factory for NACE applications.

3. Trim offerings limited to Quick Change designs only.

4. Consult factory for proper actuator sizing to provide correct valve shut-off.

5. JIS and EN material equivalents are available.

21000 BS Series Bellows Seal Design

Standard construction

Bellows seal configuration is fully compatible with the standard 21000 Series trim and actuator options providing equivalent capacity capabilities for each valve size. The standard packing box design and packing design options are used as a secondary stem seal.

Bonnet-less construction

The newly re-designed bellows section for our globe control valves up to 4"/DN100, now featuring an integrated bonnet and a streamlined component structure. This innovative upgrade significantly reduces the number of parts, improving reliability, simplifying maintenance, and enhancing overall valve performance. By integrating the bonnet directly into the bellows assembly, we've minimized potential leak paths and increased system integrity, delivering a more robust solution for demanding control applications.

Rugged design

The formed bellows construction is an externally pressurized design that is capable of operating up to the full valve ANSI B16.34 pressure rating. Guides are located above and below the bellows providing excellent stability to withstand flow induced and mechanical vibration.

Extended life

The bellows assembly is designed for 50% compression and extension (zero stress) at the valve mid-stroke position to help maximize cycle life. Bellows torsional stresses are also reduced with the anti-rotation feature provided by flats on the plug stem.

High quality

Each bellows subassembly is helium leak tested to verify weld integrity, and is also hydro-statically tested as part of the complete valve assembly. Mechanical travel stops are also designed into both the bellows and valve assemblies to prevent over compression or extension.

Smart solution

Bellows installed cycle life can be monitored in the field by utilizing **Masoneilan's SVI™ Digital Positioner** with actual process data. This advanced preventative maintenance option will help improve plant safety by identifying potential hazardous failures before they happen, and cut cost by reducing premature bellows replacement.

Bellows materials standard material

316/316L stainless steel

Optional materials

- Hastelloy C276
- Monel 400
- Inconel 625

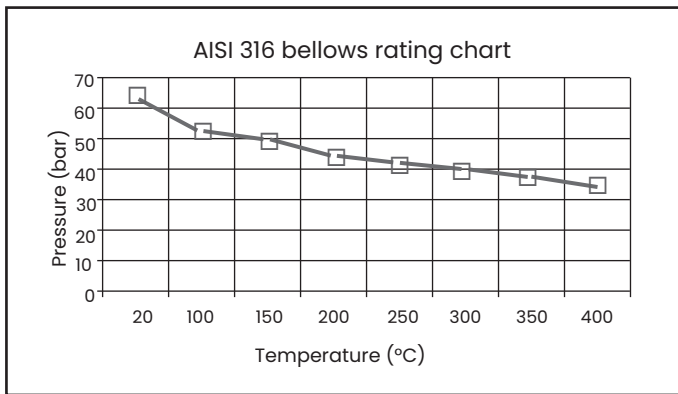

Size and ratings

Pressure ratings: ASME Class 150 and 300 – PN 20 and PN 50

Valve size	Bellows design stroke		Life cycle ratings ¹		
	Inches	mm	100%	50%	25%
.75"-2"	75	19	100,000 Full Cycles	600,000 Full Cycles	3,000,000 Full Cycles
3"-4"	1.50	38.1			
6"	2.00	50.8			

1. Minimum expected average cycle life for Class 300 (PN 50) bellows operating at constant pressure.
2. Consult Masoneilan for Bellows applications above ASME Class 300 (PN 50).

21000 BS Series Bonnet-less Design Materials of Construction

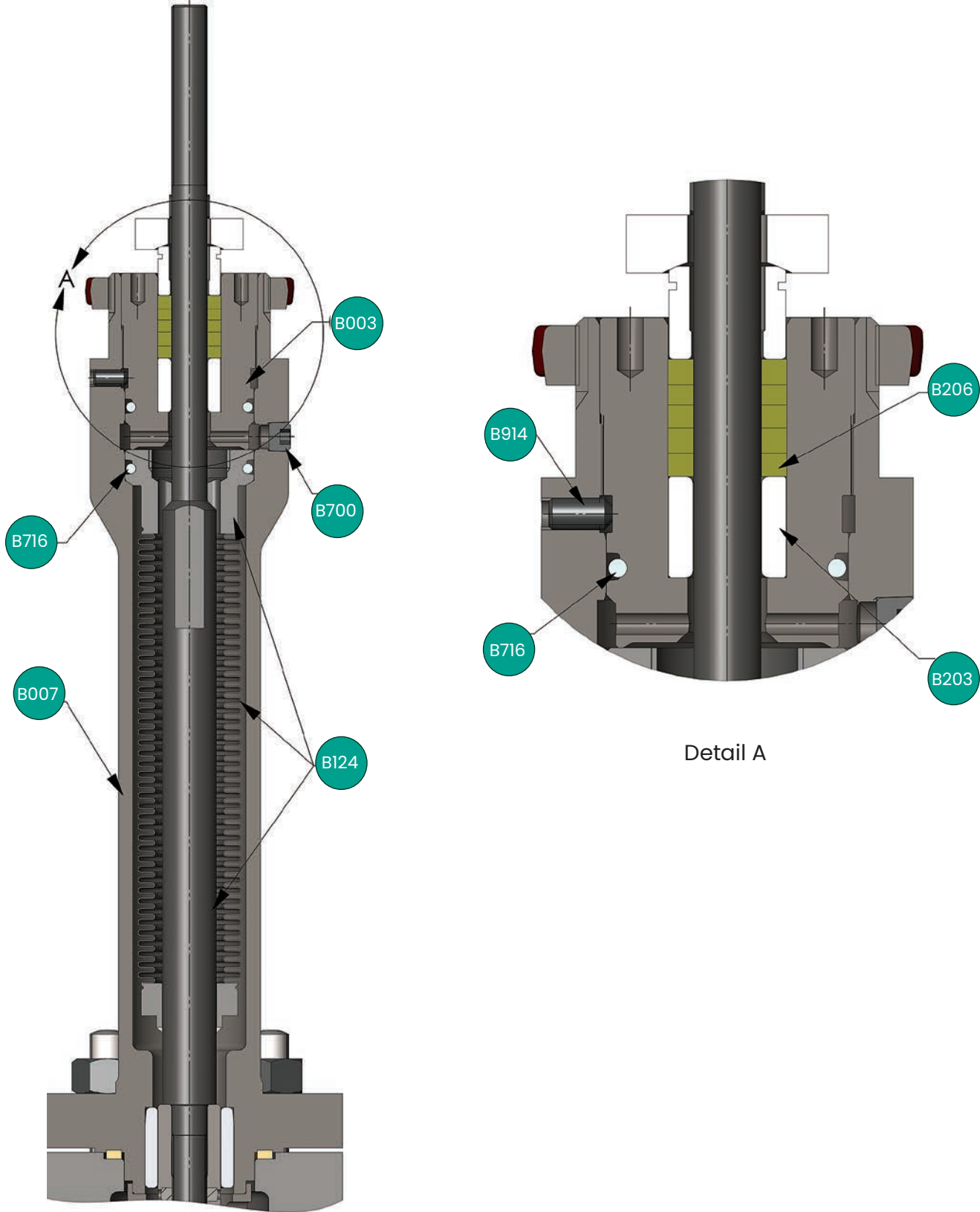

21000 BS Series Bonnet-less Design - 0.75" to 4"

21000 BS Series Bonnet-less Design

Materials of Construction

Carbon Steel Body Version⁽¹⁾

Valve Sizes: 0.75" to 4"

Body Ratings: ANSI Class 150 to 300

Ref. No. ⁽²⁾	Temperature Range		-50°F (-46°C)	-20°F (-29°C)	650°F (343°C)	800°F (427°C)
	Description		Materials			
B003	Bonnet Spud ⁽²⁾		SOLUTION ANNEALED 316 STAINLESS STEEL			
B007	Extended Bonnet		ASTM A216 GRADE WCC/WCB/EN 1.0619/1.0625			
			ASTM A352 GR LCC HRC 22 MAXIMUM			
B124	Stainless Steel Bellows and Stem Assembly	Stem ⁽²⁾	SOLUTION ANNEALED 316 STAINLESS STEEL			
		Bellow	316Ti STAINLESS STEEL			
		Upper Adapter Lower Adapter	GENERAL SERVICE ANNEALED 316L STAINLESS STEEL			
	Hastelloy C ⁽³⁾ Bellows and Stem Assembly	Stem ⁽²⁾	HASTELLOY C276 HRC 35 MAXIMUM			
		Bellow	HASTELLOY C276			
		Upper Adapter Lower Adapter	HASTELLOY C276 HRC 35 MAXIMUM			
	Monel 400 ⁽³⁾ Bellows and Stem Assembly	Stem ⁽²⁾	ASTM B164 CLASS A (UNS N04400)			
		Bellow	ASTM B164 CLASS A (UNS N04400)			
		Upper Adapter Lower Adapter	ASTM B164 CLASS A (UNS N04400)			
	Inconel 625 ⁽³⁾ Bellows and Stem Assembly	Stem ⁽²⁾	INCONEL X-750			
		Bellow	ASTM B446 (UNS N00625)			
		Upper Adapter Lower Adapter	ASTM B446 (UNS N00625)			
B203	Packing Bushing		STELLITE NO.6 OR EQUIVALENT			
B206	Packing		CARBON CORE BRAIDED PTFE PACKING			
B700	Plug – 1/8" NPT		AUSTENITIC STAINLESS STEEL			
B716	O-Ring		VITON-A 65-75 SHORE A			
B914	Hex. Socket Set Screw		A4-80 (ISO 3506) 316L			

1. Materials for other components are same as listed for Standard Carbon Steel Construction.

2. Items No. 1 (plug stem) and 8 (bonnet) in Standard Materials of Construction tables are replaced by B124 (stem) and B003 (bonnet spud) in above table.

3. Optional Hastelloy C, Monel 400 and Inconel 625 Bellows Construction available.

21000 BS Series Bonnet-less Design Materials of Construction

Stainless Steel Body Version⁽¹⁾

Valve Sizes: 0.75" to 4"

Body Ratings: ANSI Class 150 to 300

Ref. No. ⁽²⁾	Temperature Range		-20°F (-29°C)	800°F (427°C)
	Description		Materials	
B003	Bonnet Spud ⁽²⁾		SOLUTION ANNEALED 316 STAINLESS STEEL	
B007	Extended Bonnet		ASTM A351 GRADE CF8M / EN 1.4408	
B124	Stainless Steel Bellows and Stem Assembly	Stem ⁽²⁾	SOLUTION ANNEALED 316 STAINLESS STEEL	
		Bellow	316Ti STAINLESS STEEL	
		Upper Adapter Lower Adapter	GENERAL SERVICE ANNEALED 316L STAINLESS STEEL	
	Hastelloy C ⁽³⁾ Bellows and Stem Assembly	Stem ⁽²⁾	HASTELLOY C276 HRC 35 MAXIMUM	
		Bellow	HASTELLOY C276	
		Upper Adapter Lower Adapter	HASTELLOY C276 HRC 35 MAXIMUM	
	Monel 400 ⁽³⁾ Bellows and Stem Assembly	Stem ⁽²⁾	ASTM B164 CLASS A (UNS N04400)	
		Bellow	ASTM B164 CLASS A (UNS N04400)	
		Upper Adapter Lower Adapter	ASTM B164 CLASS A (UNS N04400)	
	Inconel 625 ⁽³⁾ Bellows and Stem Assembly	Stem ⁽²⁾	INCONEL X-750	
		Bellow	ASTM B446 (UNS N00625)	
		Upper Adapter Lower Adapter	ASTM B446 (UNS N00625)	
B203	Packing Bushing		STELLITE OR EQUIVALENT NO. 6	
B206	Packing		CARBON CORE BRAIDED PTFE PACKING	
B700	Plug – 1/8" NPT		AUSTENITIC STAINLESS STEEL	
B716	O-Ring		VITON-A 65-75 SHORE A	
B914	Hex. Socket Set Screw		A4-80 (ISO 3506) 316L	

1. Materials for other components are same as listed for Standard Carbon Steel Construction.

2. Items No. 1 (plug stem) and 8 (bonnet) in Standard Materials of Construction tables are replaced by B124 (stem) and B003 (bonnet spud) in above table.

3. Optional Hastelloy C, Monel 400 and Inconel 625 Bellows Construction available.

21000 BS Series Bonnet Design Materials of Construction

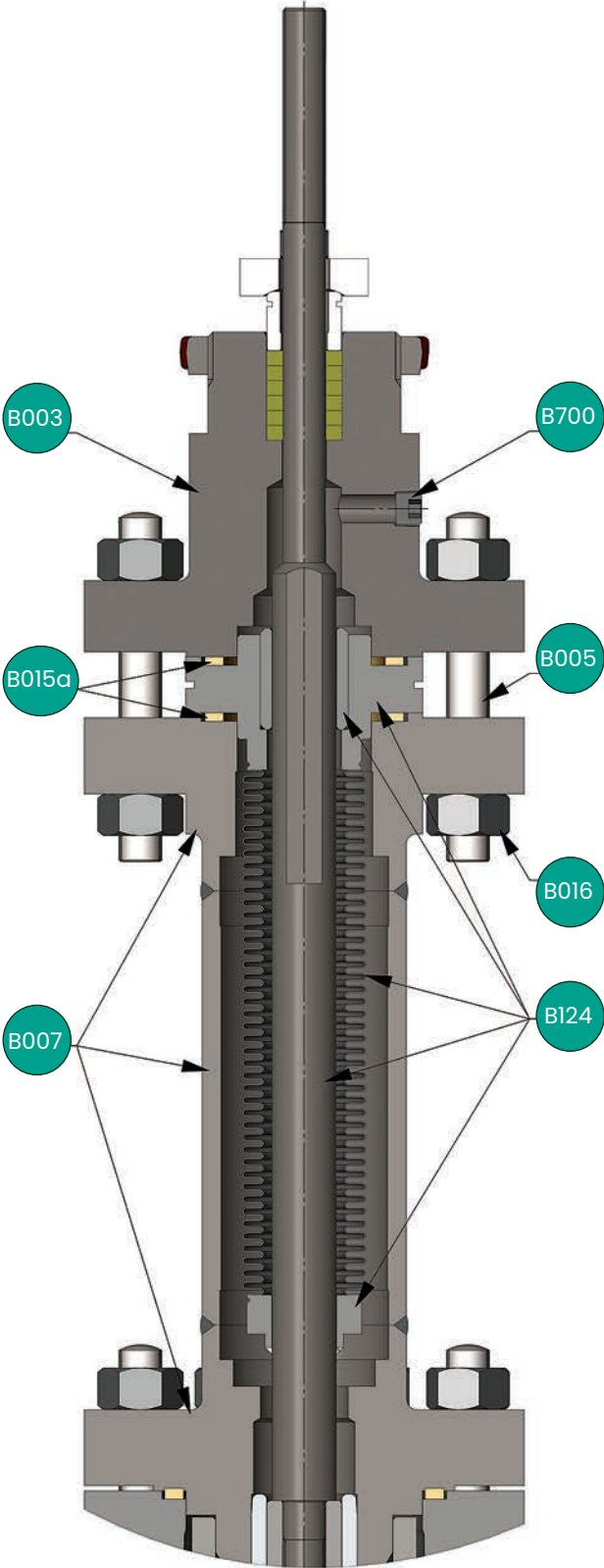

21000 BS Series Bonnet Design - 6"

21000 BS Series Bonnet Design

Materials of Construction

Carbon Steel Body Version⁽¹⁾

Ref. No.	Temperature Range		-20°F (-29°C)	800°F (427°C)
	Description		Materials	
B003	Valve Bonnet ⁽²⁾		ASTM A216 GRADE WCC/WCB or ASTM A105	
B005	Bonnet Stud		ASTM A193 GRADE B7	
B007	Carbon Steel Bonnet Extension Assembly	Upper Flange	ASTM A216 GRADE WCC or ASTM A105	
		Spacer	ASTM A106 GRADE B HRC 22 MAXIMUM	
		Lower Flange	ASTM A216 GRADE WCC	
B015a	Bonnet Spacer Gasket		316L ST ST SPIRAL WOUND GASKET WITH GRAPHITE FILLER	
B016	Bonnet Nut		ASTM A194 GRADE 2H	
B124	Stainless Steel Bellows and Stem Assembly	Stem ⁽²⁾	SOLUTION ANNEALED 316 STAINLESS STEEL	
		Guide Bushing	ASTM A479	
		Bellows	316 STAINLESS STEEL ASTM A240/A312	
		Upper Adapter Lower Adapter	GENERAL SERVICE ANNEALED 316L ST ST	
	Hastelloy C ⁽³⁾ Bellows and Stem Assembly	Stem ⁽²⁾	ASTM B574	
		Guide Bushing	STELLITE OR EQUIVALENT NO. 6	
		Bellows	Hastelloy C276 ASTM B575/B622	
	Monel 400 ⁽³⁾ Bellows and Stem Assembly	Upper Adapter Lower	ASTM B574	
		Stem ⁽²⁾	ASTM B164 CLASS A (UNS N04400)	
		Guide Bushing	STELLITE OR EQUIVALENT NO. 6	
		Bellows	ASTM B164 CLASS A (UNS N04400)	
	Inconel 625 ⁽³⁾ Bellows and Stem Assembly	Upper Adapter Lower	ASTM B164 CLASS A (UNS N04400)	
		Stem ⁽²⁾	INCONEL X-750	
		Guide Bushing	STELLITE OR EQUIVALENT NO. 6	
		Bellows	ASTM B446 (UNS N00625)	
	B700	Plug – 1/8" NPT	Upper Adapter Lower	ASTM B446 (UNS N00625)
			ASTM A234 GRADE WPB	

1. Materials for other components are same as listed for Standard Carbon Steel Construction.

2. Items No. 1 (plug stem) and 8 (bonnet) in Standard Materials of Construction tables are replaced by items B124 (stem) and B003 (valve bonnet) in above table.

3. Optional Hastelloy C, Monel 400 and Inconel 625 Bellows Construction available.

21000 BS Series Bonnet Design

Materials of Construction

Stainless Steel Body Version⁽¹⁾

Ref . No.	Temperature Range		-20°F (-29°C)	650°F (343°C)	800°F (427°C)
	Description		Materials		
B003	Valve Bonnet ⁽²⁾		ASTM A351 GRADE CF8M or ASTM A182 GRADE F 316		
B005	Bonnet Stud		ASTM A193 GR B7 – ZINC PLATING	ASTM A193 GRADE B7	
B007	Carbon Steel Bonnet Extension Assembly	Upper Flange	ASTM A351 GRADE CF8M or ASTM A182 GRADE F 316		
		Spacer	316 STAINLESS STEEL ASTM A269 TY 316		
		Lower Flange	ASTM A351 GRADE CF8M		
B015a	Bonnet Spacer Gasket		316L STAINLESS STEEL SPIRAL WOUND GASKET WITH GRAPHITE FILLER		
B016	Bonnet Nut		ASTM A194 GR 2H – ZINC PLATING	ASTM A194 GRADE 2H	
B124	Stainless Steel Bellows and Stem Assembly	Stem ⁽²⁾	SOLUTION ANNEALED 316 STAINLESS STEEL		
		Guide Bushing	ASTM A479		
		Bellows	316 STAINLESS STEEL ASTM A240/A312		
		Upper Adapter Lower Adapter	GENERAL SERVICE ANNEALED 316L STAINLESS STEEL		
	Hastelloy C ⁽³⁾ Bellows and Stem Assembly	Stem ⁽²⁾	ASTM B574		
		Guide Bushing	STELLITE OR EQUIVALENT NO. 6		
		Bellows	HASTELLOY C276 ASTM B575/B622		
		Upper Adapter Lower	ASTM B574		
	Monel 400 ⁽³⁾ Bellows and Stem Assembly	Stem ⁽²⁾	ASTM B164 CLASS A (UNS N04400)		
		Guide Bushing	STELLITE OR EQUIVALENT NO. 6		
		Bellows	ASTM B164 CLASS A (UNS N04400)		
		Upper Adapter Lower	ASTM B164 CLASS A (UNS N04400)		
	Inconel 625 ⁽³⁾ Bellows and Stem Assembly	Stem ⁽²⁾	INCONEL X-750		
		Guide Bushing	STELLITE OR EQUIVALENT NO. 6		
		Bellows	ASTM B446 (UNS N00625)		
		Upper Adapter Lower	ASTM B446 (UNS N00625)		
B700	Plug – 1/8" NPT		AUSTENITIC STAINLESS STEEL		

1. Materials for other components are same as listed for Standard Stainless Steel Construction.

2. Items No. 1 (plug stem) and 8 (bonnet) in Standard Materials of Construction tables are replaced by items B124 (plug stem) and B003 (valve bonnet) in above table.

3. Optional Hastelloy C, Monel 400 and Inconel 625 Bellows Construction available.

Dimensions (inches)

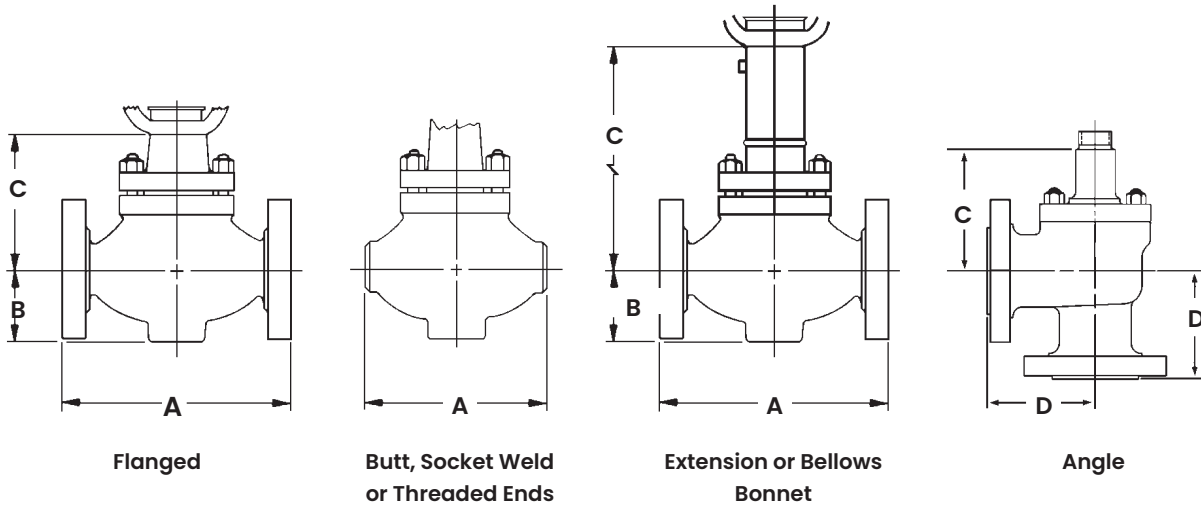

21000 Series Dimensions (inches)

Valve Size (inches)	A													
	ASME Class 150-600 (PN 20-100)	ASME Class 900-1500 (PN 150-250)	ASME Class 2500 (PN 420)	ASME Class 150 (PN 20)	ASME Class 300 (PN 50)		ASME Class 600 (PN 100)		ASME Class 900 (PN 150)		ASME Class 1500 (PN 250)		ASME Class 2500 (PN 420)	
	BW, SW, THD	BW, SW, THD	BW, SW, THD	RF	RF	RTJ	RF	RTJ	RF	RTJ	RF	RTJ	RF	RTJ
0.75	8.25	8.50	12.50	7.25	7.63	8.11	8.11	8.11	10.75	10.75	10.75	10.75	12.12	12.12
1	8.25	8.50	12.50	7.25	7.75	8.25	8.25	8.25	11.50	11.50	11.50	11.50	12.50	12.50
1.5	9.88	9.25	13	8.75	9.25	9.76	9.88	9.88	13.12	13.12	13.12	13.12	14.12	14.25
2	11.25	11.50	14.75	10	10.50	11.12	11.25	11.38	14.75	14.88	14.75	14.88	16.25	16.37
3	13.24	12.50		11.75	12.50	13.12	13.25	13.38	15.24	15.31	15.99	16.06		
4	15.50	14.49		13.88	14.50	15.12	15.50	15.62	18.27	18.34	19.02	19.09		
6	20			17.75	18.62	19.25	20	20.12						
8	24			21.38	22.36	22.83	24	24.09						

Valve Size (inches)	B														
	ANSI Class 150-300 (PN 20-50)		ANSI Class 600 (PN 100)	ANSI Class 150-600 (PN 20-100)		ANSI Class 900-1500 (PN 150-250)		ANSI Class 2500 (PN 420)		ANSI Class 150 (PN 20)	ANSI Class 300 (PN 50)	ANSI Class 600 (PN 100)	ANSI Class 900 (PN 150)	ANSI Class 1500 (PN 250)	ANSI Class 2500 (PN 420)
	BW	BW	SW & THD	BW	SW	BW	SW	RF	RF & RTJ	RF & RTJ	RF & RTJ	RF & RTJ	RF & RTJ	RF & RTJ	
0.75			1.83		2.15		2.42	2	2.29	2.29	2.29	2.59	2.59	2.79	
1			1.83		2.15		2.42	2.19	2.49	2.49	2.49	2.98	2.98	3.18	
1.5			2.50		2.81		3.17	2.50	3.08	3.08	3.08	3.57	3.57	4.06	
2	3	3	3	3.53	3.53	3.87	3.87	3	3.28	3.30	3.30	4.26	4.26	4.66	
3	3.69	3.69		4.36				3.77	4.16	4.16	4.16	4.72	5.22		
4	5	5.50		5.75				4.98	5.05	5.50	5.50	5.75	6.10		
6	6.26	7.37						6.26	6.36	7.37					
8	7.68	7.68						7.68	7.68	8.27					

Dimensions (inches)

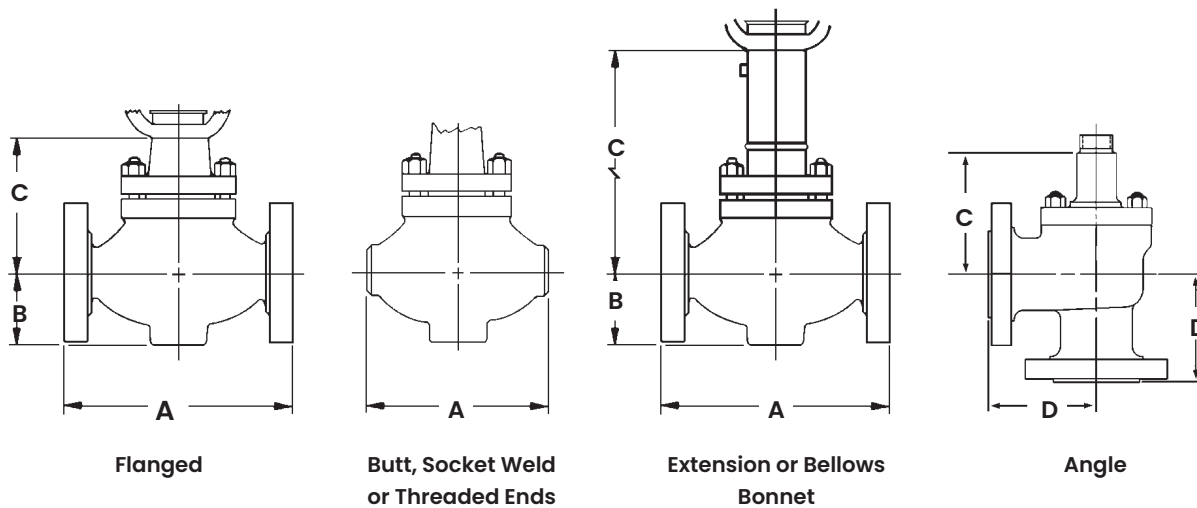

21000 Series Dimensions (inches)

Valve Size (inches)	C											
	Standard Bonnet				Extension Bonnet				Cryogenic Extension Bonnet			Bellows Bonnet
	ASME Class 150-300 (PN 20-50)	ASME Class 600 (PN 100)	ASME Class 900-1500 (PN 150-250)	ASME Class 2500 (PN 420)	ASME Class 150-300 (PN 20-50)	ASME Class 600 (PN 100)	ASME Class 900-1500 (PN 150-250)	ASME Class 2500 (PN 420)	ASME Class 150-600 (PN 20-100)	ASME Class 900-1500 (PN 150-250)	ASME Class 2500 (PN 420)	ASME Class 150-300 (PN 20-50)
0.75	5.65	5.65	7.69	7.69	9.78	9.78	10.76	10.76	23.70	23.80	23.80	13.15
1	5.65	5.65	7.69	7.69	9.78	9.78	10.76	10.76	23.70	23.80	23.80	13.15
1.5	5.51	5.51	9	9	10	10	11.70	11.70	23.70	23.70	23.70	13.15
2	5.51	5.51	9	9	10	10	11.70	11.70	23.70	23.70	23.70	13.15
3	8	8	11.35		12.50	12.50	13.70		27.64	27.78		24.76
4	8.05	9.43	14.94		12.56	12.56	17.44		27.64	27.83		24.85
6	11.20	11.13			17.06	16.63			31.84			43.85
8	16.66	16.66			22.78	22.78			34.71			

Valve Size (inches)	D																	
	ASME Class 150-600 (PN 20-100)		ASME Class 900-1500 (PN 150-200)		ASME Class 2500 (PN 420)		ASME Class 150 (PN 20)		ASME Class 300 (PN 50)		ASME Class 600 (PN 100)		ASME Class 900 (PN 150)		ASME Class 1500 (PN 250)		ASME Class 2500 (PN 420)	
	BW, SW, THD	BW, SW, THD	BW, SW, THD	RF	RF	RTJ	RF	RTJ	RF	RTJ	RF	RTJ	RF	RTJ	RF	RTJ	RF	RTJ
0.75	4.13	4.25	6.25	3.63	3.87	4.13	4.13	4.13	5.38	5.38	5.38	5.38	6.06	6.06				
1	4.13	4.25	6.25	3.63	3.87	4.13	4.13	4.13	5.75	5.75	5.75	5.75	6.25	6.25				
1.5	4.94	4.63	6.50	4.37	4.63	4.88	4.95	4.94	6.56	6.56	6.56	6.56	7.06	7.12				
2	5.63	5.57	7.38	5	5.25	5.56	5.63	5.69	7.37	7.44	7.37	7.44	8.13	8.19				
3	6.63			5.87	6.25	6.56	6.63	6.69										
4	7.75			6.94	7.25	7.56	7.75	7.81										
6	10.00			8.87	9.31	9.63	10	10.06										
8																		

Dimensions (mm)

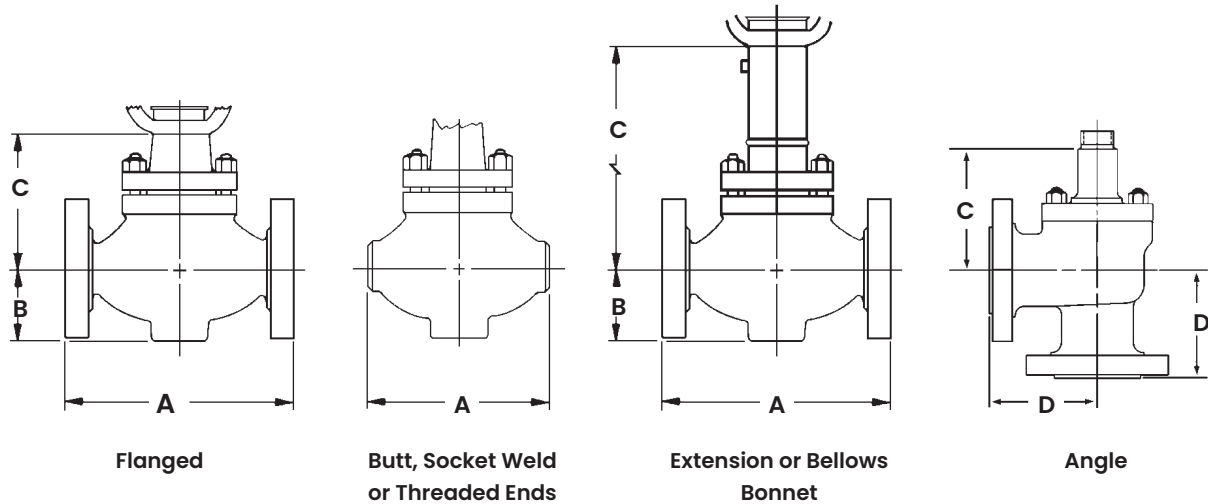

21000 Series Dimensions (mm)

Valve Size (mm)	A																	
	ASME Class 150-600 (PN 20-100)		ASME Class 900-1500 (PN 150-250)		ASME Class 2500 (PN 420)		ASME Class 150 (PN 20)		ASME Class 300 (PN 50)		ASME Class 600 (PN 100)		ASME Class 900 (PN 150)		ASME Class 1500 (PN 250)		ASME Class 2500 (PN 420)	
	BW, SW, THD	BW, SW, THD	BW, SW, THD	RF	RF	RTJ	RF	RTJ	RF	RTJ	RF	RTJ	RF	RTJ	RF	RTJ	RF	RTJ
20	210	216	318	184	194	206	206	206	273	273	273	273	308	308				
25	210	216	318	184	197	210	210	210	292	292	292	292	318	318				
40	251	235	330	222	235	248	251	251	333	333	333	333	359	362				
50	286	292	375	254	267	283	286	289	375	378	375	378	413	416				
80	336	318		299	318	333	337	340	387	389	406	408						
100	394	368		353	368	384	394	397	464	466	483	485						
150	508			451	473	489	508	511										
200	610			543	568	580	610	612										

Valve Size (mm)	B																						
	ANSI Class 150-300 (PN 20-50)		ANSI Class 600 (PN 100)		ANSI Class 150-600 (PN 20-100)		ANSI Class 900-1500 (PN 150-250)		ANSI Class 2500 (PN 420)		ANSI Class 150 (PN 20)		ANSI Class 300 (PN 50)		ANSI Class 600 (PN 100)		ANSI Class 900 (PN 150)		ANSI Class 1500 (PN 250)		ANSI Class 2500 (PN 420)		
	BW	BW	SW & THD	BW	SW	BW	SW	RF	RF & RTJ	RF & RTJ	RF & RTJ	RF & RTJ	RF & RTJ	RF & RTJ	RF & RTJ	RF & RTJ	RF & RTJ	RF & RTJ	RF & RTJ	RF & RTJ	RF & RTJ	RF & RTJ	
20			47		55		62	51	58	58	66	66	71										
25			47		55		62	56	63	63	76	76	81										
40			64		72		81	64	78	78	91	91	103										
50	76	76	76	90	90	96	98	76	83	84	108	108	118										
80	95	95		111				96	106	106	120	133											
100	127	140		146				127	128	140	146	155											
150	159	187						159	162	187													
200	195	195						195	195	210													

Dimensions (mm)

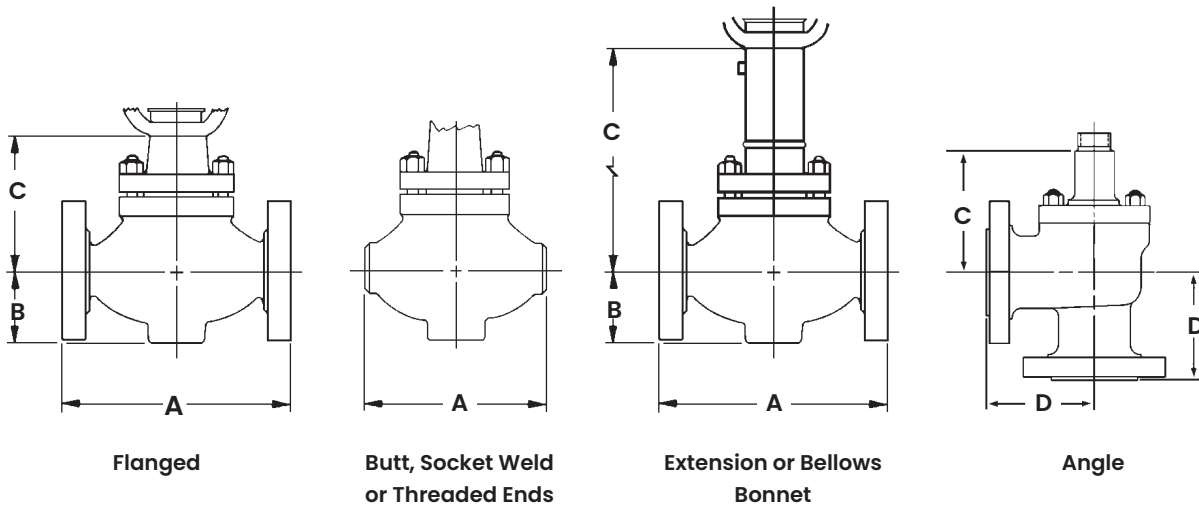

21000 Series Dimensions (mm)

Valve Size (mm)	C											
	Standard Bonnet				Extension Bonnet				Cryogenic Extension Bonnet			Bellows Bonnet
	ASME Class 150-300 (PN 20-50)	ASME Class 600 (PN 100)	ASME Class 900-1500 (PN 150-250)	ASME Class 2500 (PN 420)	ASME Class 150-300 (PN 20-50)	ASME Class 600 (PN 100)	ASME Class 900-1500 (PN 150-250)	ASME Class 2500 (PN 420)	ASME Class 150-600 (PN 20-100)	ASME Class 900-1500 (PN 150-250)	ASME Class 2500 (PN 420)	ASME Class 150-300 (PN 20-50)
20	144	144	195	195	249	249	273	273	602	604	604	334
25	144	144	195	195	249	249	273	273	602	604	604	334
40	140	140	228	228	254	254	297	297	602	602	602	334
50	140	140	228	228	254	254	297	297	602	602	602	334
80	203	203	288		317	317	348		702	706		629
100	205	240	380		319	319	443		702	707		631
150	284	283			424	422			808			1114
200	423	423			579				882			

Valve Size (mm)	D													
	ASME Class 150-600 (PN 20-100)	ASME Class 900-1500 (PN 150-250)	ASME Class 2500 (PN 420)	ASME Class 150 (PN 20)	ASME Class 300 (PN 50)		ASME Class 600 (PN 100)		ASME Class 900 (PN 150)		ASME Class 1500 (PN 250)		ASME Class 2500 (PN 420)	
	BW, SW, THD	BW, SW, THD	BW, SW, THD	RF	RF	RTJ	RF	RTJ	RF	RTJ	RF	RTJ	RF	RTJ
20	105	108	159	92	98	105	105	105	137	137	137	137	154	154
25	105	108	159	92	98	105	105	105	146	146	146	146	159	159
40	126	118	165	111	118	124	126	126	167	167	167	167	179	181
50	143	142	188	127	133	141	143	145	187	189	187	189	206	208
80	168			149	159	167	168	170						
100	197			176	184	192	197	198						
150	254			225	237	244	254	256						
200														

Weights

Body S/A with Standard Bonnet (lbs)

Valve Size (inches)	ASME Class 150 – 300 (PN 20 – 50)		ASME Class 600 (PN 100)		ASME Class 900 – 1500 (PN 150 – 250)		ASME Class 2500 (PN 420)	
	FLG	BW, SW & THD	FLG	BW, SW & THD	FLG	BW, SW & THD	FLG	BW, SW & THD
0.75	24	18	26	18	75	53	99	66
1	24	18	26	18	75	53	99	66
1.5	42	35	44	35	99	77	150	93
2	49	44	51	44	143	101	201	128
3	101	73	119	99	254	170		
4	159	134	218	185	483	346		
6	302	238	430	276				
8	796	741	827	741				

Body S/A with Standard Bonnet (kg)

Valve Size (mm)	ASME Class 150 – 300 (PN 20 – 50)		ASME Class 600 (PN 100)		ASME Class 900 – 1500 (PN 150 – 250)		ASME Class 2500 (PN 420)	
	FLG	BW, SW & THD	FLG	BW, SW & THD	FLG	BW, SW & THD	FLG	BW, SW & THD
20	11	8	12	8	34	24	45	30
25	11	8	12	8	34	24	45	30
40	19	16	20	16	45	35	68	42
50	22	20	23	20	65	46	91	58
80	46	33	54	45	115	77		
100	72	61	99	84	219	157		
150	137	108	195	125				
200	361	336	375	336				

Bellows Seal Assembly Additional Weights

Valve Size		Estimated Additional Weight	
inch	mm	lbs	kg
0.75 to 2	20 to 50	6	3
3 to 4	80 to 100	17	8
6	150	73	33

Note: 21000 Bellow Seal Series are limited to Class rating 150-300

API 6A 21000 Series High Pressure Design

API 6A 21000 Series Valve is offered from 0.75 to 1 inch, with API class 10 kPSI [690 bar] to 15 kPSI [1034 bar].

This design consists of a single ported, cage guided control valve designed to meet API 6A standards for high pressure applications:

Forged Body

Forged bodies will meet 15 kPSI (1034 bar) in operation.

Integral Bonnet

Designed with an integral bonnet, the API 6A 21000 Series Valve has a smaller profile and reduced weight.

Integral Internal Components

Seat and cage are one piece allowing for ease of installation and maintenance.

Flow Characteristic

Linear characteristic is standard.

Trim Options

Full area and reduced trims are available for optimal control.

Leakage Rate

Class IV and V leakage is standard as per IEC-60534-4.

Hardened Trim

For longer service life, hardened trim is provided to handle high pressure.

Packing

Standard packing and environmental LOW E packing options are available to comply with application requirements.

NACE Compliance

NACE MR0175 and ISO 15156-1 compatible materials are available.

Size and Ratings

Pressure ratings: API class from 10 kPSI [690 bar] to 15 kPSI [1034 bar]

End Connections and Shut Off

Valve Size (in)	Valve Ends Size (NPS)	Body Rating	Packing Material	Seat Type	Temperature Range								Seat Leakage Class IEC 60534-4 and ANSI and FCI 70-2	
					Stainless Steel F6NM		Duplex Stainless Steel F51		Duplex Stainless Steel F55		Inconel 718™			
					Min.	Max.	Min.	Max.	Min.	Max.	Min.	Max.		
0.75 to 1 <small>(1), (2), (3)</small>	1"-13/16 (1.8125)	API 10K API 15K	PTFE	Metal	-75°F (-60°C)	+350°F (+180°C)	-50°F (-46°C)	+350°F (+180°C)	-50°F (-46°C)	+350°F (+180°C)	-75°F (-60°C)	+350°F (+180°C)	IV	V

1. Pressure drop is limited at 10 kPSI [690 bar] for the 15 kPSI [1034 bar] valve.
2. API 6A 21000 valves are designed as control valves, not as isolating valves.
3. Lifting lugs are provided for handling.

API 6A 21000 Series C_v and F_L Versus Travel

API 10K and 15K – FTO Models 21114

Direction: FLOW-TO-OPEN (FTO)
Flow Characteristic: LINEAR

Sizes: 3/4" through 1" Contoured API 10K & 15K – Flow to Close																
Travel (Percent)							10	20	30	40	50	60	70	80	90	100
FL							0.93	0.93	0.92	0.91	0.91	0.91	0.91	0.90	0.90	0.90
Valve Size	Valve Ends Size	API 6A Rating	Orifice Dia.		Travel		Rated C _v									
			inch	mm	inch	mm										
inch	mm		inch	mm	inch	mm										
0.75	1"-13/16	10000 and 15000	0.25	6.35	0.8	20.32	0.07	0.21	0.33	0.44	0.55	0.64	0.74	0.84	0.94	1
			0.25	6.35	0.8	20.32	0.22	0.34	0.47	0.65	0.85	1.03	1.20	1.39	1.60	1.7
			0.375	9.53	0.8	20.32	0.81	1.41	1.91	2.32	2.69	2.99	3.24	3.48	3.75	3.8
1	1"-13/16	10000 and 15000	0.50	12.70	0.8	20.32	1.03	1.78	2.49	3.14	3.74	4.28	4.88	5.64	6.43	6
			0.812	20.64	0.8	20.32	2.28	3.85	5.31	6.60	7.66	8.96	10.24	11.04	11.57	12

API 10K and 15K – FTC Models 21114

Direction: FLOW-TO-CLOSE (FTC)
Flow Characteristic: LINEAR

Sizes: 3/4" through 1" Contoured API 10K & 15K – Flow to Close																
Travel (Percent)							10	20	30	40	50	60	70	80	90	100
FL							0.53	0.56	0.60	0.68	0.75	0.78	0.81	0.84	0.85	0.86
Valve Size	Valve Ends Size	API 6A Rating	Orifice Dia.		Travel		Rated C _v									
			inch	mm	inch	mm										
inch	mm		inch	mm	inch	mm										
0.75	1"-13/16	10000 & 15000	0.25	6.35	0.8	20.32	0.30	0.50	0.66	0.90	1.14	1.38	1.61	1.78	1.87	1.9
			0.375	9.53	0.8	20.32	1.07	1.86	2.42	2.75	3.15	3.58	3.85	3.99	4.17	4.2
1	1"-13/16	10000 & 15000	0.50	12.70	0.8	20.32	1.20	2.25	2.97	3.46	3.83	4.27	4.88	5.87	6.94	7
			0.812	20.64	0.8	20.32	2.46	4.29	5.62	6.56	7.38	8.41	10.01	12.10	12.67	13

API 6A 21000 Series Materials of Construction

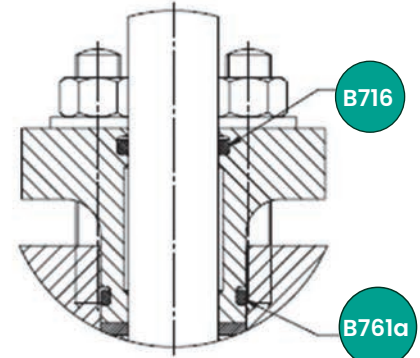
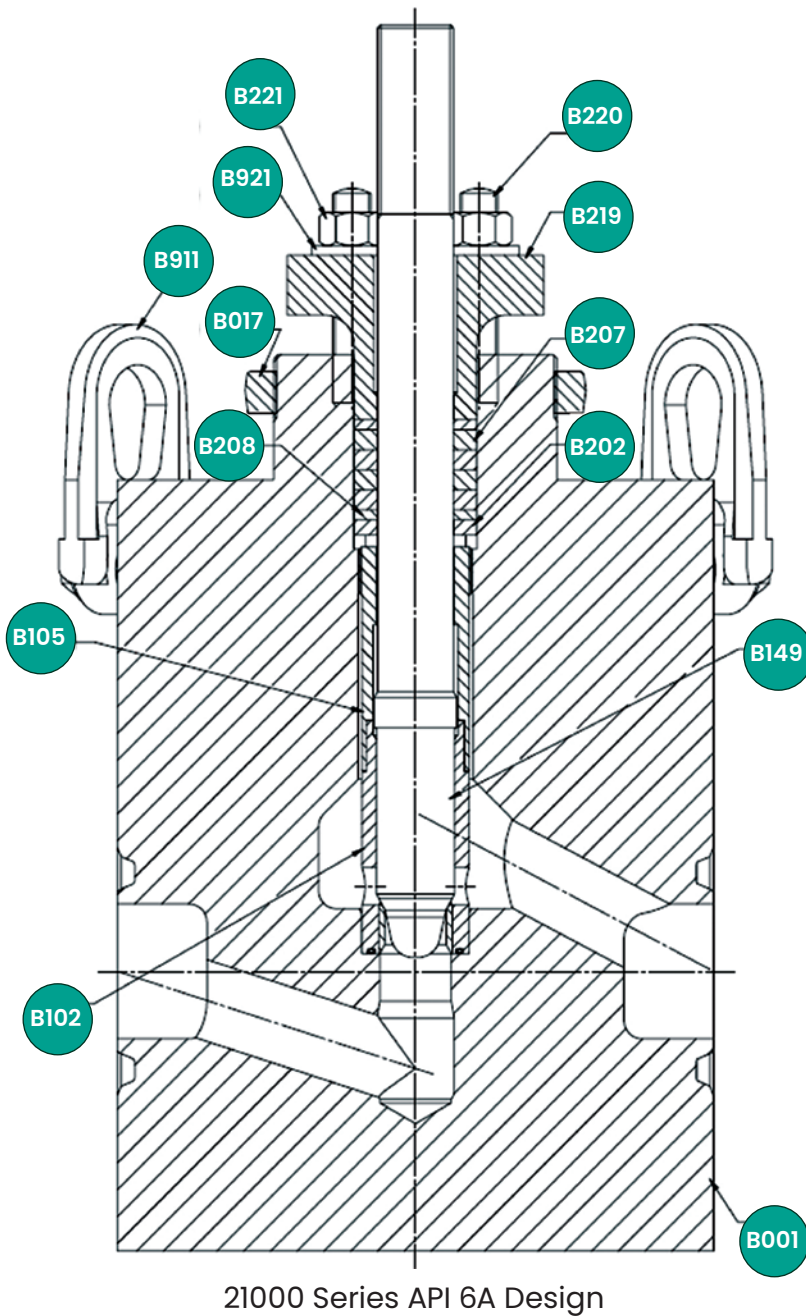

Flow-to-Close
Seat-Ring Gasket Detail

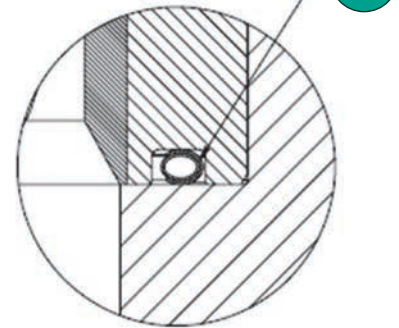
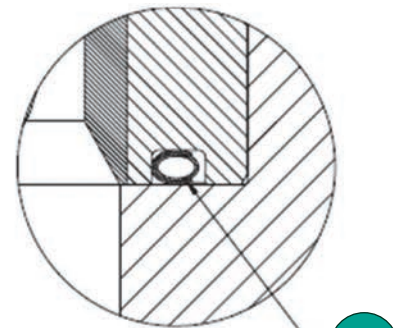

Flow-to-Open
Seat-Ring Gasket Detail

Part Tag Codes	Valve Body S/A Part Description	Part Tag Codes	Valve Body S/A Part Description
B001	Valve Body	B202	Packing Spacer
B017	Drive Nut	B207	Packing Ring
B102	Integral Seat-Ring and Cage	B208	Anti-Extrusion Ring
B103	Seat-Ring Gasket	B219	Integral Packing Flange and Follower
B105	Trim Retainer	B716	O-Ring
B149	Integral Plug and Stem	B716a	O-Ring
B220	Packing Flange Stud	B911	Lifting Lug
B221	Packing Flange Nut	B921	Flat Washer

API 6A 21000 Series Materials of Construction

Material Class vs Material of Construction

Material Class		Material of Construction Availability			
		Stainless Steel F6NM	Duplex Stainless Steel F51	Duplex Stainless Steel F55	Inconel 718™
AA	General Service	X	X	X	X
BB	General Service	X	X	X	X
CC	General Service	X	X	X	X

Material Class		Material of Construction Availability			
		Stainless Steel F6NM	Duplex Stainless Steel F51	Duplex Stainless Steel F55	Inconel 718™
DD	Sour Service				X
EE	Sour Service				X
FF	Sour Service	X	X	X	X
HH	Sour Service				X

Temperature Rating vs Material of Construction

Temperature Ratings	Temperature Range				Material of Construction Availability			
	Min °C	Max °C	Min °F	Max °F	Stainless Steel F6NM	Duplex Stainless Steel F51	Duplex Stainless Steel F55	Inconel 718™
K	-60	82	-75	180	X			X
L	-46	82	-50	180	X	X	X	X
N	-46	60	-50	140	X	X	X	X
P	-29	82	-20	180	X	X	X	X
S	-18	60	0	140	X	X	X	X
T	-18	82	0	180	X	X	X	X
U	-18	121	0	250	X	X	X	X
V	2	121	35	250	X	X	X	X
X	-18	180	0	350	X	X	X	X

API 6A 21000 Series

Materials of Construction

Standard Martensitic Stainless-Steel Construction

Max operating pressure: 15 kPSI [1034 bar]

Temperature class: K/L/N/P/S/T/U/V/X ⁽¹⁾

Material class: AA/BB/CC/FF ⁽¹⁾

Ref. No.	Temperature Range ⁽¹⁾	-76°F (-60°C)	-20°F (-29°C)	250°F (121°C)	356°F (180°C)	
		Description				Materials ⁽¹⁾
B001	Body	ASTM A182 GR F6NM API6A				
					ASTM A182 GR F6NM API6A ELEVATED TEMPERATURE X	
B017	Drive Nut	SOLUTION ANNEALED 316 STAINLESS STEEL HRC 22 MAXIMUM . HARDNESS COMPLIANCE WITH NACE MR0103 & MR0175 SHALL BE CERTIFIED				
B102	Integral Seat-Ring and Cage	ASTM A182 GR F6NM CL B + CHROME PLATING + STELLITE NO. 6 HARDFACING				
B103	Seat-Ring Gasket	INCONEL 718 + SILVER PLATING				
B105	Retainer	SUPER AUSTENITIC STAINLESS STEEL UNS S20910 (NITRONIC 50) 35 HRC MAXIMUM				
B149	Integral Plug and Stem ⁽⁴⁾	ASTM A182 GR F6NM API6A as per CMS-7011 + STELLITE NO. 6 HARDFACING				
					ASTM A182 GR F6NM API6A ELEVATED TEMPERATURE X + STELLITE NO. 6 HARDFACING	
B220	Packing Flange Stud ⁽⁵⁾	ASTM A193 GRADE B7 ZINC PLATED ⁽²⁾				
		ASTM A193 GR B7M ELECTROLESS NICKEL PLATING ⁽³⁾				
		ASTM A320 Gr L7 ZINC PLATED ⁽²⁾				
		ASTM A320 Gr L7M ELECTROLESS NICKEL PLATING ⁽³⁾				
B221	Packing Flange Nut ⁽⁵⁾	ASTM A194 GR 7 ZINC PLATED ⁽²⁾				
		ASTM A194 GR 7M ELECTROLESS NICKEL PLATING ⁽³⁾				
		ASTM A 194 GR 2H ZINC PLATED ⁽²⁾				
		ASTM A194 GR 2HM, ELECTROLESS NICKEL PLATING ⁽³⁾				
B202	Packing Spacer	CA6NM CLASS B STAINLESS STEEL HB 255 MAXIMUM				
B207	Packing Ring	LATTYFLON 3265 LM (NO EQUIVALENTS ALLOWED)				
B208	Anti-Extrusion Ring	CARBON-GRAPHITE BRAIDED LATTYGRAF 6995NG (NO EQUIVALENTS ALLOWED)				
B213	Packing Flange and Follower ⁽⁴⁾	ASTM A182 GR F6NM API6A				
					ASTM A182 GR F6NM API6A ELEVATED TEMPERATURE X	
B716/ B716a	O-ring	VITON-A 65-75 SHORE A				
B921	Flat Washer ⁽⁵⁾	ASTM F436 ZINC PLATED				
		410 STAINLESS STEEL HRC 35-45				

Notes:

1. Refer to tables on page 43.
2. For General Service only: Nace Non-Exposed per ANSI and NACE MR0175/ISO 15156-1.
3. For Sour Service only: Nace Exposed per ANSI and NACE MR0175/ISO 15156-1.
4. Considered as pressure containing parts in API 6A specification. See Design Practice BHPD10046.
5. Zinc electroplating is not permitted for splash zone or subsea service.

API 6A 21000 Series Materials of Construction

Duplex F51 Stainless-Steel Construction

Max operating pressure: 10 kPSI [690 bar]

Temperature class: L/N/P/S/T/U/V/X ⁽¹⁾

Material class: AA/BB/CC/FF ⁽¹⁾

Ref. No.	Temperature Range ⁽¹⁾	-51°F (-46°C)	-20°F (-29°C)	250°F (121°C)	356°F (180°C)	
		Description				Materials ⁽¹⁾
B001	Body	ASTM A182 GR F51 API6A				
					ASTM A182 GR F51 API6A ELEVATED TEMPERATURE X	
B017	Drive Nut	SOLUTION ANNEALED 316 STAINLESS STEEL HRC 22 MAXIMUM. HARDNESS COMPLIANCE WITH NACE MR0103 & MR0175 SHALL BE CERTIFIED				
B102	Integral Seat-Ring and Cage	ASTM A 479 UNS S31803 + STELLITE NO. 6 + CHROME PLATING				
B103	Seat-Ring Gasket	INCONEL 718 + SILVER PLATING				
B105	Retainer	SUPER AUSTENITIC STAINLESS STEEL UNS S20910 (NITRONIC 50) 35 HRC MAXIMUM				
B149	Integral Plug and Stem ⁽⁴⁾	ASTM A182 GR F51 API6A + STELLITE NO. 6 HARDFACING				
					ASTM A182 GR F51 API6A ELEVATED TEMPERATURE X + STELLITE NO. 6 HARDFACING	
B220	Packing Flange Stud ⁽⁵⁾	ASTM A193 GRADE B7 ZINC PLATED ⁽²⁾				
		ASTM A193 GR B7M ELECTROLESS NICKEL PLATING ⁽³⁾				
		ASTM A320 Gr L7 ZINC PLATED ⁽²⁾				
		ASTM A320 Gr L7M ELECTROLESS NICKEL PLATING ⁽³⁾				
B221	Packing Flange Nut ⁽⁵⁾	ASTM A194 GR 7 ZINC PLATED ⁽²⁾				
		ASTM A194 GR 7M ELECTROLESS NICKEL PLATING ⁽³⁾				
		ASTM A 194 GR 2H ZINC PLATED ⁽²⁾				
		ASTM A194 GR 2HM, ELECTROLESS NICKEL PLATING ⁽³⁾				
B202	Packing Spacer	SOLUTION ANNEALED 2205 STAINLESS STEEL (DUPLEX) HRC 28 MAXIMUM				
B207	Packing Ring	LATTYFLON 3265 LM (NO EQUIVALENTS ALLOWED)				
B208	Anti-Extrusion Ring	CARBON-GRAPHITE BRAIDED LATTYGRAF 6995NG (NO EQUIVALENTS ALLOWED)				
B213	Packing Flange and Follower ⁽⁴⁾	ASTM A182 GR F51 API6A				
					ASTM A182 GR F51 API6A ELEVATED TEMPERATURE X	
B716/ B716a	O-ring	VITON-A 65-75 SHORE A				
B921	Flat Washer ⁽⁵⁾	ASTM F436 ZINC PLATED				
		410 STAINLESS STEEL HRC 35-45				

Notes:

1. Refer to tables on page 43.
2. For General Service only: Nace Non-Exposed per ANSI and NACE MR0175/ISO 15156-1.
3. For Sour Service only: Nace Exposed per ANSI and NACE MR0175/ISO 15156-1.
4. Considered as pressure containing parts in API 6A specification. See Design Practice BHDPI0046.
5. Zinc electroplating is not permitted for splash zone or subsea service.

API 6A 21000 Series Materials of Construction

Super Duplex F55 Stainless-Steel Construction

Max operating pressure: 15 kPSI [1034 bar]

Temperature class: L/N/P/S/T/U/V/X ⁽¹⁾

Material class: AA/BB/CC/FF ⁽¹⁾

Ref. No.	Temperature Range ⁽¹⁾	-51°F (-46°C)	-20°F (-29°C)	250°F (121°C)	356°F (180°C)
		Materials ⁽¹⁾			
Description					
B001	Body	ASTM A182 GR F55 API6A			
					ASTM A182 GR F55 API6A ELEVATED TEMPERATURE X
B017	Drive Nut	SOLUTION ANNEALED 316 STAINLESS STEEL HRC 22 MAXIMUM. HARDNESS COMPLIANCE WITH NACE MR0103 AND MR0175 SHALL BE CERTIFIED			
B102	Integral Seat-Ring and Cage	ASTM A 479 UNS S32760 + STELLITE NO. 6 + CHROME PLATING			
B103	Seat-Ring Gasket	INCONEL 718 + SILVER PLATING			
B105	Retainer	SUPER AUSTENITIC STAINLESS STEEL UNS S20910 (NITRONIC 50) 35 HRC MAXIMUM			
B149	Integral Plug and Stem ⁽²⁾	ASTM A182 GR F55 API6A + STELLITE NO. 6 HARDFACING			
					ASTM A182 GR F55 API6A ELEVATED TEMPERATURE X + STELLITE NO. 6 HARDFACING
B220	Packing Flange Stud ⁽⁵⁾		ASTM A193 GRADE B7 ZINC PLATED ⁽²⁾		
			ASTM A193 GR B7M ELECTROLESS NICKEL PLATING ⁽³⁾		
			ASTM A320 Gr L7 ZINC PLATED ⁽²⁾		
			ASTM A320 Gr L7M ELECTROLESS NICKEL PLATING ⁽³⁾		
B221	Packing Flange Nut ⁽⁵⁾		ASTM A194 GR 7 ZINC PLATED ⁽²⁾		
			ASTM A194 GR 7M ELECTROLESS NICKEL PLATING ⁽³⁾		
			ASTM A 194 GR 2H ZINC PLATED ⁽²⁾		
			ASTM A194 GR 2HM, ELECTROLESS NICKEL PLATING ⁽³⁾		
B202	Packing Spacer	SUPER DUPLEX AUSTENO-FERRITIQUE STAINLESS STEEL (TYPE UNS S32760) HRC 32 MAXIMUM			
B207	Packing Ring	LATTYFLON 3265 LM (NO EQUIVALENTS ALLOWED)			
B208	Anti-Extrusion Ring	CARBON-GRAPHITE BRAIDED LATTYGRAF 6995NG (NO EQUIVALENTS ALLOWED)			
B213	Packing Flange and Follower ⁽⁴⁾	ASTM A182 GR F55 API6A			
					ASTM A182 GR F55 API6A ELEVATED TEMPERATURE X
B716/ B716a	O-ring	VITON-A 65-75 SHORE A			
B921	Flat Washer ⁽⁵⁾	ASTM F436 ZINC PLATED			
		410 ST. ST. HRC 35-45			

Notes:

1. Refer to tables on page 43.
2. For General Service only: Nace Non-Exposed per ANSI and NACE MR0175/ISO 15156-1.
3. For Sour Service only: Nace Exposed per ANSI and NACE MR0175/ISO 15156-1.
4. Considered as pressure containing parts in API 6A specification. See Design Practice BHDP10046.
5. Zinc electroplating is not permitted for splash zone or subsea service.

API 6A 21000 Series Materials of Construction

CRA Nickel-Alloy Inconel 718 Construction

Max operating pressure: 15 kPSI [1034 bar]

Temperature class: K/L/N/P/S/T/U/V/X ⁽¹⁾

Material class: AA/BB/CC/DD/EE/FF/HH ⁽¹⁾

Ref. No.	Temperature Range ⁽¹⁾	-76°F (-60°C)	-20°F (-29°C)	250°F (121°C)	356°F (180°C)
		Materials ⁽¹⁾			
B001	Body	UNS N07718 120K			
					UNS N07718 120K ELEVATED TEMPERATURE X
B017	Drive Nut	SOLUTION ANNEALED 316 STAINLESS STEEL HRC 22 MAXIMUM HARDNESS COMPLIANCE WITH NACE MR0103 AND MR0175 SHALL BE CERTIFIED			
		ASTM B637 GRADE NO7718 (UNS 07718) HRC 40 MAXIMUM HARDNESS COMPLIANCE WITH NACE MR0103 SHALL BE CERTIFIED			
B102	Integral Seat-Ring and Cage	UNS N07718 120K			
					UNS N07718 120K ELEVATED TEMPERATURE X
B103	Seat-Ring Gasket	INCONEL 718 + SILVER PLATING			
B105	Retainer	SUPER AUSTENITIC STAINLESS STEEL UNS S20910 (NITRONIC 50) 35 HRC MAXIMUM			
B149	Integral Plug and Stem ⁽⁴⁾	UNS N07718 120K			
					UNS N07718 120K ELEVATED TEMPERATURE X
B220	Packing Flange Stud ⁽⁵⁾		ASTM A193 GRADE B7 ZINC PLATED ⁽²⁾		
			ASTM A193 GR B7M ELECTROLESS NICKEL PLATING ⁽³⁾		
			ASTM A320 Gr L7 ZINC PLATED ⁽²⁾		
			ASTM A320 Gr L7M ELECTROLESS NICKEL PLATING ⁽³⁾		
B221	Packing Flange Nut ⁽⁵⁾		ASTM A194 GR 7 ZINC PLATED ⁽²⁾		
			ASTM A194 GR 7M ELECTROLESS NICKEL PLATING ⁽³⁾		
			ASTM A 194 GR 2H ZINC PLATED ⁽²⁾		
			ASTM A194 GR 2HM, ELECTROLESS NICKEL PLATING ⁽³⁾		
B202	Packing Spacer	ASTM B637 GRADE NO7718 (UNS 07718) HRC 40 MAXIMUM HARDNESS COMPLIANCE WITH NACE MR0103 SHALL BE CERTIFIED			
B207	Packing Ring	LATTYFLON 3265 LM (NO EQUIVALENTS ALLOWED)			
B208	Anti-Extrusion Ring	CARBON-GRAPHITE BRAIDED LATTYGRAF 6995NG (NO EQUIVALENTS ALLOWED)			
B213	Packing Flange and Follower ⁽⁴⁾	UNS N07718 120K			
					UNS N07718 120K ELEVATED TEMPERATURE X
B716/ B716a	O-ring	VITON-A 65-75 SHORE A			
B921	Flat Washer ⁽⁵⁾	ASTM F436 ZINC PLATED			
		410 ST. ST. HRC 35-45			

Notes:

1. Refer to tables on page 43.
2. For General Service only: Nace Non-Exposed per ANSI and NACE MR0175/ISO 15156-1.
3. For Sour Service only: Nace Exposed per ANSI and NACE MR0175/ISO 15156-1.
4. Considered as pressure containing parts in API 6A specification. See Design Practice BHPD10046.
5. Zinc electroplating is not permitted for splash zone or subsea service.

API 6A 21000 Series Materials of Construction

Common Parts

Temperature class: K/L/N/P/S/T/U/V/X ⁽¹⁾

Material class: AA/BB/CC/DD/EE/FF/HH ⁽¹⁾

Ref. No.	Temperature Range ⁽¹⁾	-76°F (-60°C)	356°F (180°C)
	Description	Materials ⁽¹⁾	
B703	Serial Plate	GENERAL SERVICE ANNEALED 316L STAINLESS STEEL HRC 22 MAX	
B704	Flow Arrow	AUSTENITIC STAINLESS STEEL	
B902	Drive Screw	AUSTENITIC STAINLESS STEEL	
B911	Lifting Lugs	STAINLESS STEEL	

Notes:

1. Refer to tables on page 43.

API 6A 21000 Series Dimensions and Weights

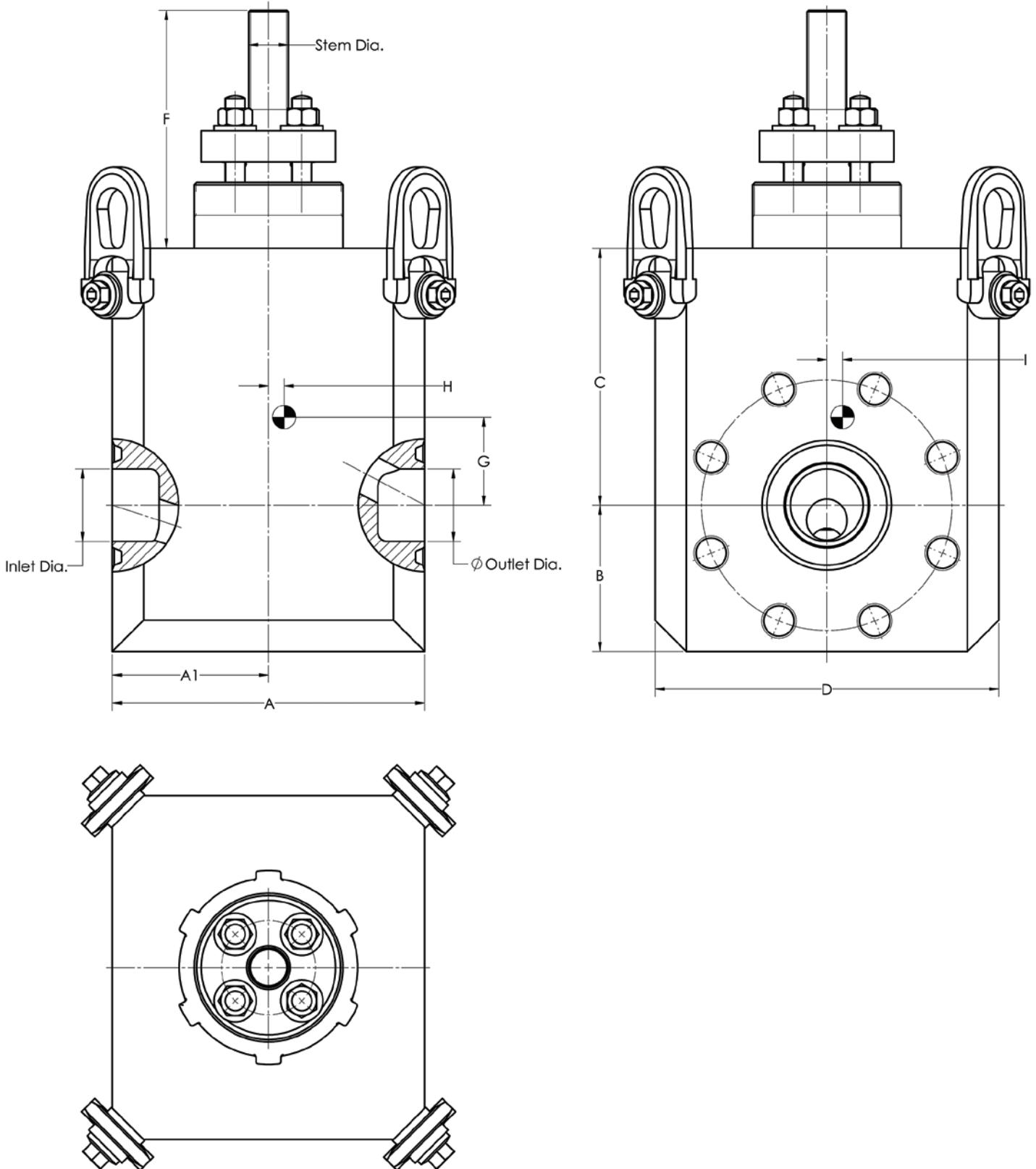

API 6A 21000 Series

Dimensions and Weights

API 10K and 15K Body S/A (mm)

Valve Trim Size (in)	Valve Ends Size (NPS)	Max Operating Pressure (PSI)	Valve Ends	Stem Diameter	Inlet Diameter	Outlet Dia.	Spud Diameter	A	A1	B	C	D	G	H	I	Approx. Mass (kg)
0.75	1"-13/16	10K	6BX	3/4" 16UNF-3A	46.45	46.45	3"-5/16 16UNS-2A	160	80	93.5	131.5	220	29.5	0	0	61
0.75	1"-13/16	15K	6BX	3/4" 16UNF-3A	46.45	46.45	3"-5/16 16UNS-2A	160	80	93.5	131.5	220	29.5	0	0	61
1	1"-13/16	10K	6BX	1" 14UNF-3A	46.45	46.45	3"-3/4 12UNS-2A	200	100	93.6	164.4	220	46	0	0	88
1	1"-13/16	15K	6BX	1" 14UNF-3A	46.45	46.45	3"-3/4 12UNS-2A	200	100	93.6	164.4	220	46	0	0	88

API 10K and 15K Body S/A (in.)

Valve Trim Size (in)	Valve Ends Size (NPS)	Max Operating Pressure (PSI)	Valve Ends	Stem Diameter	Inlet Diameter	Outlet Dia.	Spud Diameter	A	A1	B	C	D	G	H	I	Approx. Mass (lb)
0.75	1"-13/16	10K	6BX	3/4" 16UNF-3A	1.829	1.829	3"-5/16 16UNS-2A	6.299	3.150	3.681	5.175	8.661	1.161	0	0	134
0.75	1"-13/16	15K	6BX	3/4" 16UNF-3A	1.829	1.829	3"-5/16 16UNS-2A	6.299	3.150	3.681	5.175	8.661	1.161	0	0	134
1	1"-13/16	10K	6BX	1" 14UNF-3A	1.829	1.829	3"-3/4 12UNS-2A	7.874	3.937	3.681	6.472	8.661	1.811	0	0	194
1	1"-13/16	15K	6BX	1" 14UNF-3A	1.829	1.829	3"-3/4 12UNS-2A	7.874	3.937	3.681	6.472	8.661	1.811	0	0	194

Find the nearest local Channel Partner in your area:

valves.bakerhughes.com/contact-us

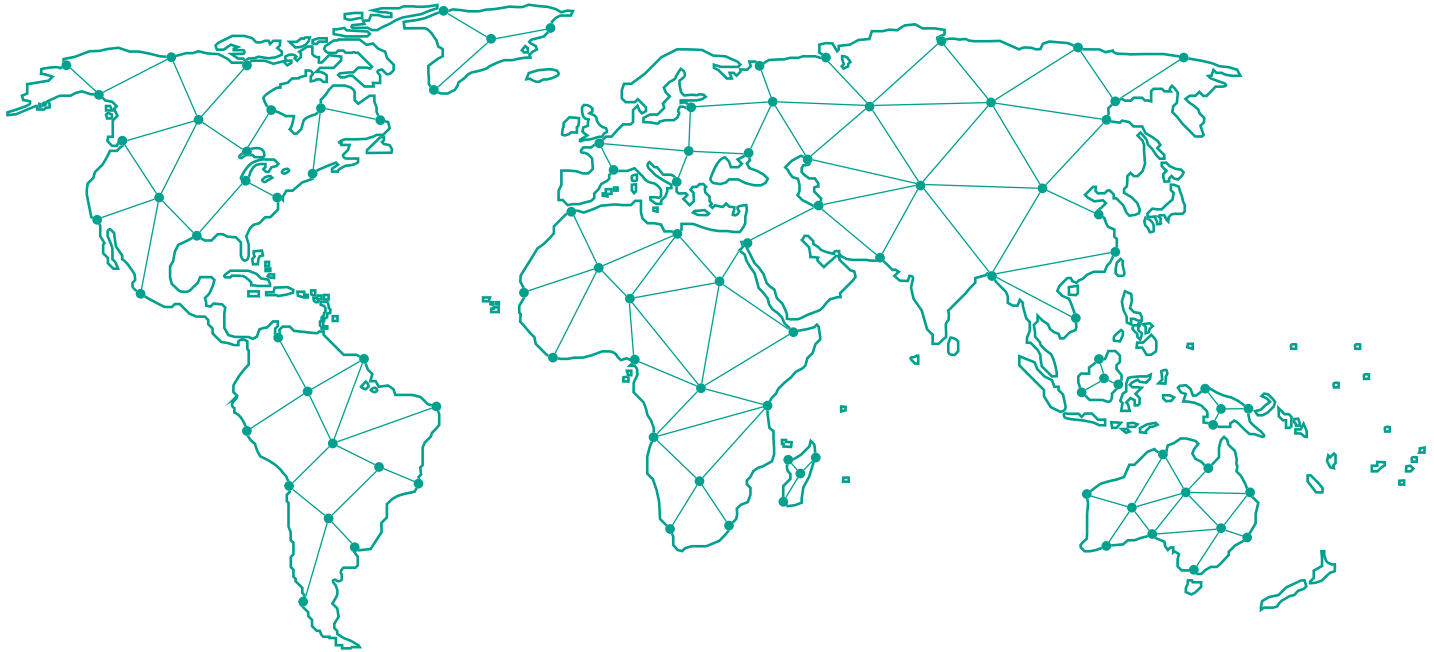

Tech Field Support and Warranty:

Phone: +1-866-827-5378
valvesupport@bakerhughes.com

valves.bakerhughes.com

Copyright 2025 Baker Hughes Company. All rights reserved. Baker Hughes provides this information on an "as is" basis for general information purposes. Baker Hughes does not make any representation as to the accuracy or completeness of the information and makes no warranties of any kind, specific, implied or oral, to the fullest extent permissible by law, including those of merchantability and fitness for a particular purpose or use. Baker Hughes hereby disclaims any and all liability for any direct, indirect, consequential or special damages, claims for lost profits, or third party claims arising from the use of the information, whether a claim is asserted in contract, tort, or otherwise. Baker Hughes reserves the right to make changes in specifications and features shown herein, or discontinue the product described at any time without notice or obligation. Contact your Baker Hughes representative for the most current information. The Baker Hughes logo, Masoneilan, Lo-dB and SVI are trademarks of Baker Hughes Company. Other company names and product names used in this document are the registered trademarks or trademarks of their respective owners.