

Series PV Variable Volume Piston Pumps

A

Catalog HY13-2600-600-3/US

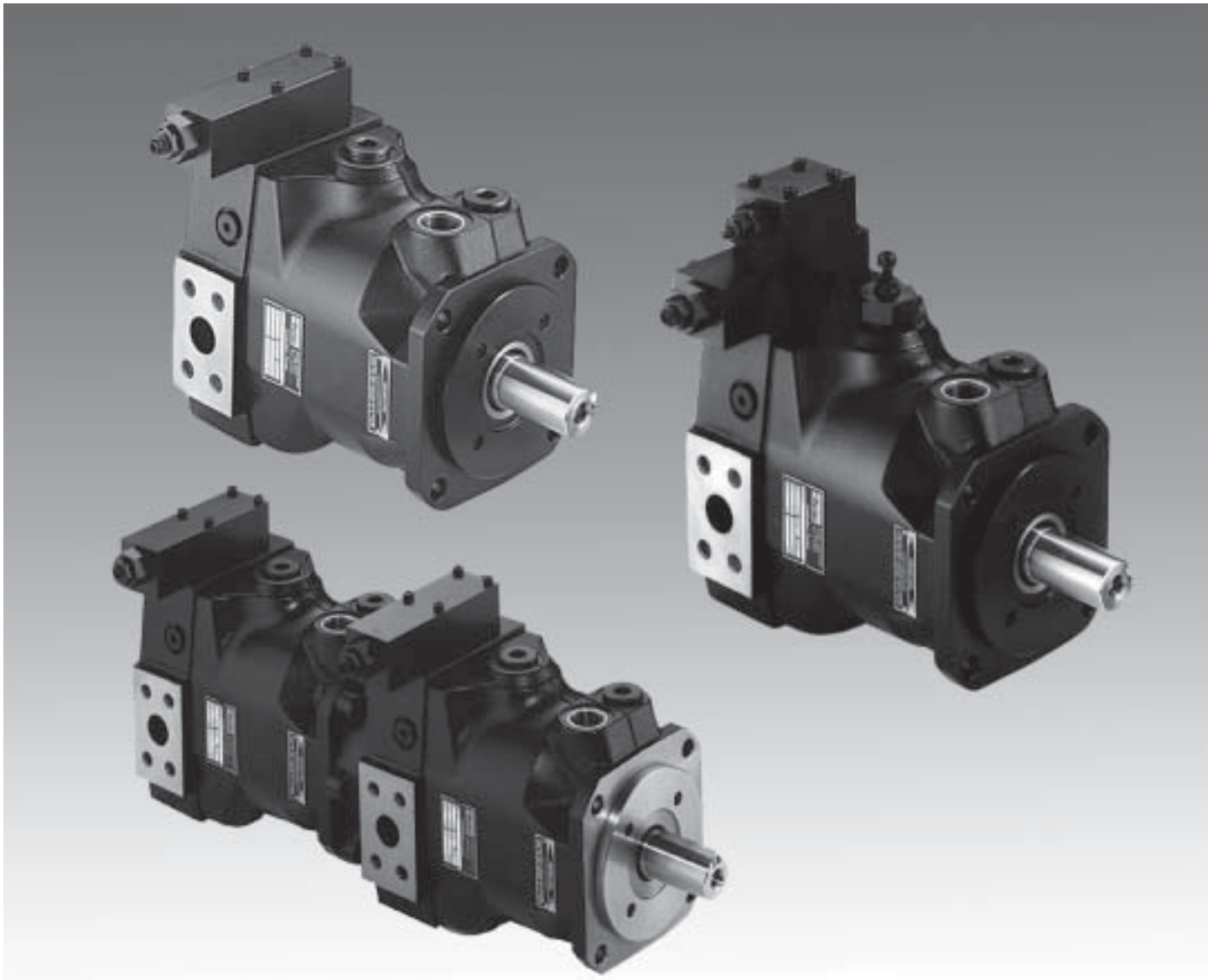

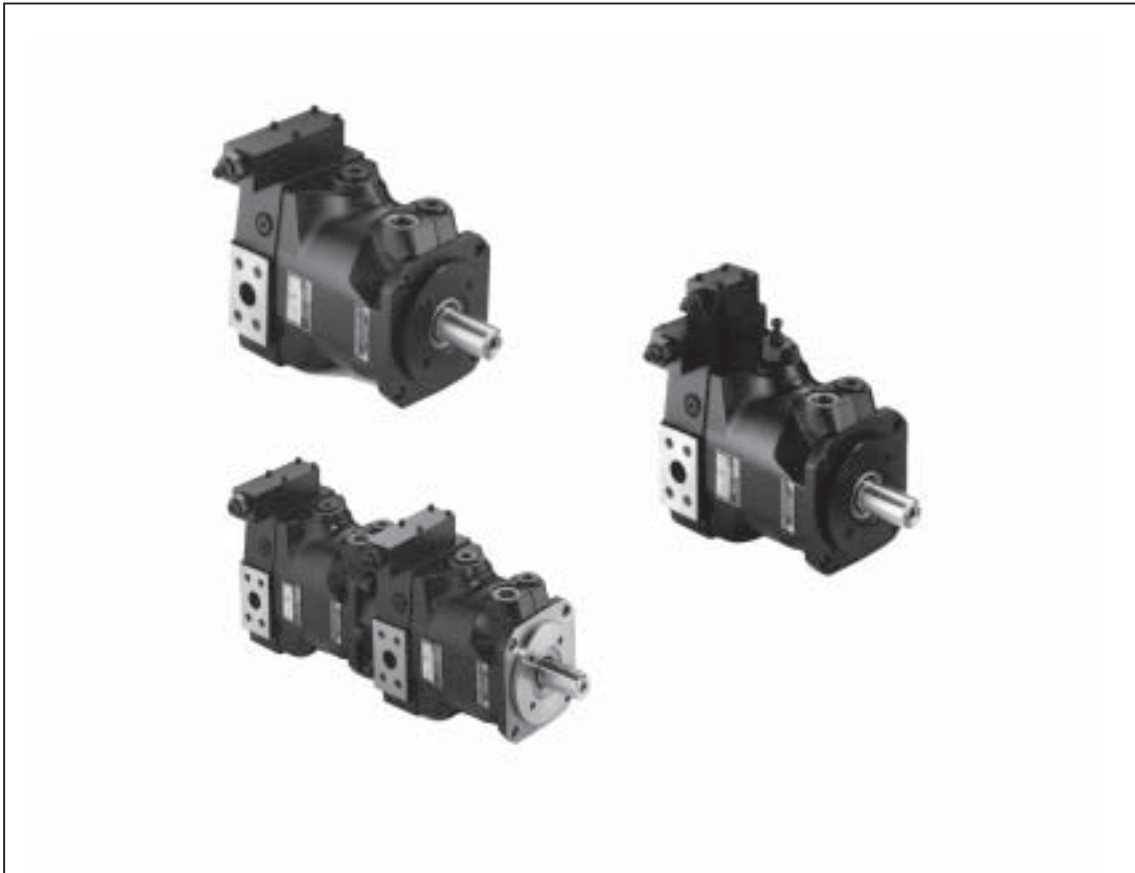

Quick Reference Data Chart

Pump Model	Displacement cc/rev (In ³ /rev)	Pump Delivery @ (7 bar) 100 PSI in LPM (GPM)		*Approx. Noise Levels dB(A) @ Full Flow and 1500 RPM			Power at 1800 RPM, Max. Displacement & 345 bar (5000 PSI)	Max. Operating Speed (RPM)
		1200 RPM	1800 RPM	70 bar	207 bar	343 bar		
				(1000 PSI)	(3000 PSI)	(5000 PSI)		
PV016	16 (.98)	19.2 (5.1)	28.8 (7.6)	56	60	68	18.5 kw (24.8 hp)	2750
PV020	20 (1.2)	24.0 (6.3)	36.0 (9.5)	56	60	68	23.4 kw (31.4 hp)	2750
PV023	23 (1.4)	27.6 (7.3)	41.4 (10.9)	56	60	68	25.1 kw (33.6 hp)	2750
PV032	32 (1.9)	38.4 (10.1)	57.6 (15.2)	59	62	69	35.1 kw (47.0 hp)	2400
PV040	40 (2.4)	48.0 (12.7)	72.0 (19.0)	59	62	69	46.5 kw (62.4 hp)	2400
PV046	46 (2.8)	55.2 (14.6)	82.8 (21.9)	59	62	69	50.2 kw (67.3 hp)	2400
PV063	63 (3.8)	75.6 (20.0)	113.4 (30.0)	66	70	74	70.1 kw (94.0 hp)	2400
PV080	80 (4.8)	96.0 (25.4)	144.0 (38.0)	66	70	74	89.2 kw (119.6 hp)	2300
PV092	92 (5.6)	110.4 (29.2)	165.6 (43.8)	66	70	74	136.8 kw (183.5 hp)	2200
PV140	140 (8.5)	168.0 (44.4)	252.1 (66.6)	70	74	76	149.4 kw (200.4 hp)	2400
PV180	180 (10.9)	216.0 (57.1)	324.0 (85.6)	71	75	77	210.0 kw (282.0 hp)	2200
PV270	270 (16.5)	324.0 (85.6)	486.0 (128.4)	77	79	81	298.0 kw (400.0 hp)	1800

* The noise level values are based on anechoic room measurements at a distance of 1 meter in accordance with DIN 45645.

General Description

All control of the pump outlet flow is achieved by the proper positioning of the swash plate. Control is accomplished when the bore area forces of the servo piston acting on one end of the swash plate working against the combined effects of the bias spring, and the rod area forces of the servo piston acting on the other end.

As the shaft in the figure below is rotated by a prime mover, it in turn rotates the cylinder barrel. As the cylinder barrel rotates, it drives the pumping pistons in a circular path with the piston slippers supported hydrostatically against the angled swash plate. In one-half of the revolution, the pumping pistons are forced

away from the port plate drawing in fluid, and in the other half of the revolution, the pumping pistons are forced toward the port plate driving out fluid.

The volume of fluid the pump will displace in one revolution of the shaft is dependent upon the area of the pumping piston, the number of pumping pistons and the angle of the swash plate. The swash plate is shown at maximum angle and will produce maximum displacement. As the swash plate is moved toward a vertical position (perpendicular to shaft centerline), the displacement will decrease until it reaches the vertical position and displacement is zero.

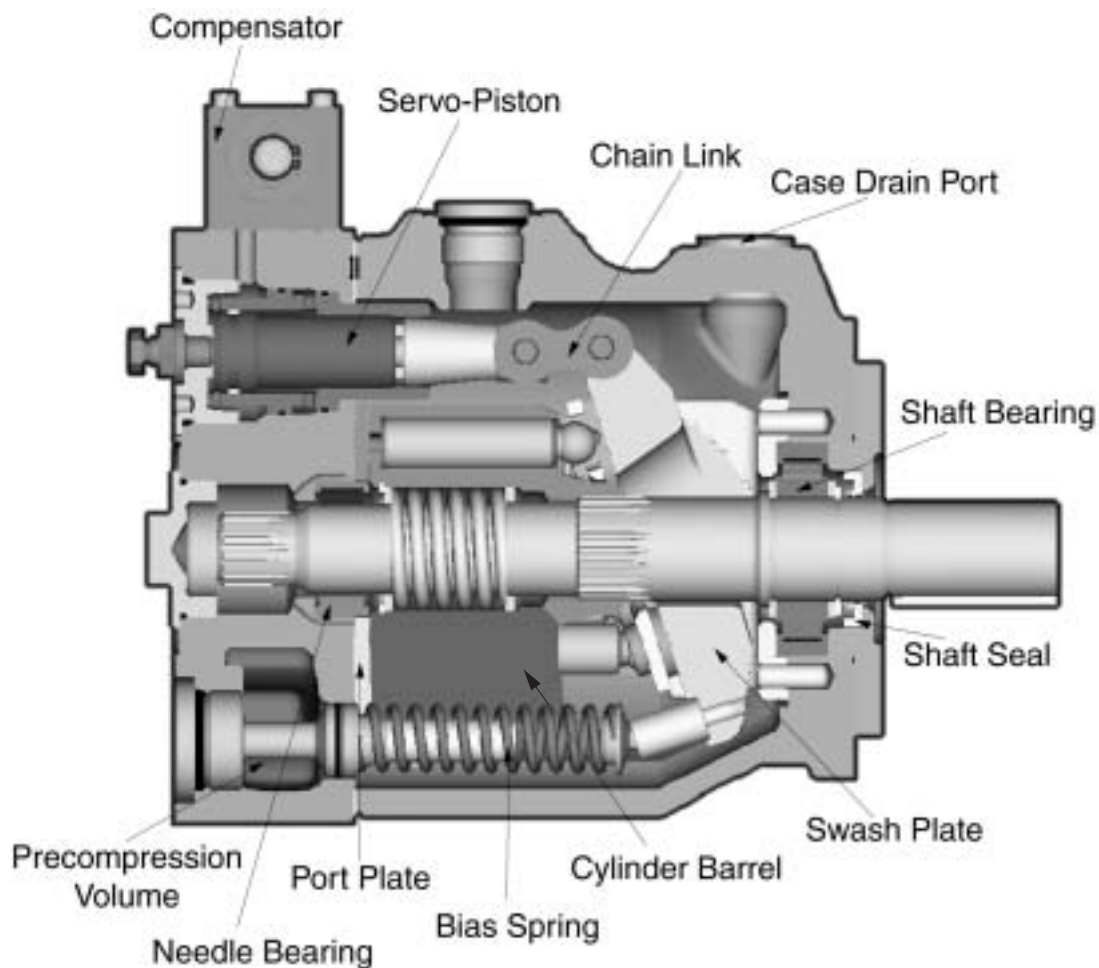

Pressure and Load Sensing Compensators

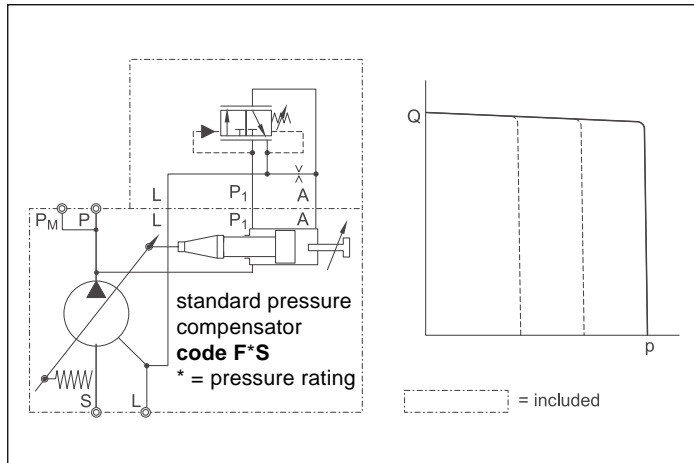

Standard pressure compensator code F*S

The standard pressure compensator adjusts the pump displacement according to the actual need of the system in order to keep the pressure constant.

As long as the system pressure at outlet port P is lower than the set pressure (set as spring preload of the compensator spring) the working port A of the compensator valve is connected to the case drain and the piston area is unloaded. Bias spring and system pressure on the annulus area keep the pump at full displacement.

When the system pressure reaches the set pressure the compensator valve spool connects port P1 to A and builds up a pressure at the servo piston resulting in a downstroking of the pump. The displacement of the pump is controlled in order to match the flow requirement of the system.

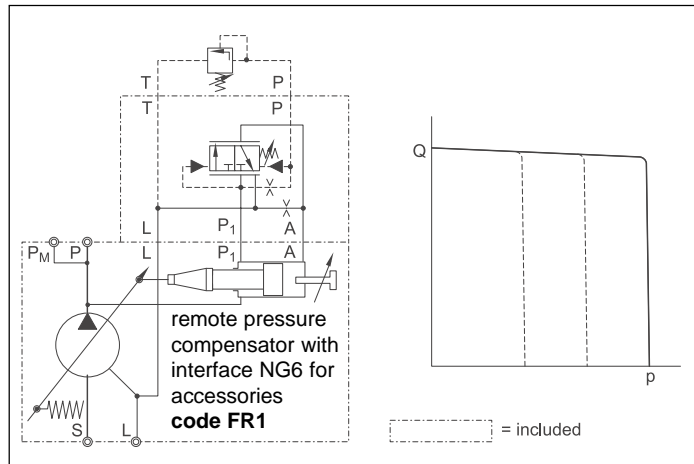

Remote pressure compensator code FR1

Version FR1 of the remote pressure compensator provides on its top side an interface NG6, DIN 24340 (CETOP 03 at RP35H, NFPA D03).

This interface allows a direct mounting of a pilot valve. Besides manual or electrohydraulic operated valves it is also possible to mount complete multiple pressure circuits directly on the compensator body. Parker offers a variety of these compensator accessories ready to install. See page 38 of this catalog.

All remote pressure compensators have a factory setting of 15 bar (217 PSI) differential pressure. With this setting, the controlled pressure at the pump outlet is higher than the pressure controlled by the pilot valve.

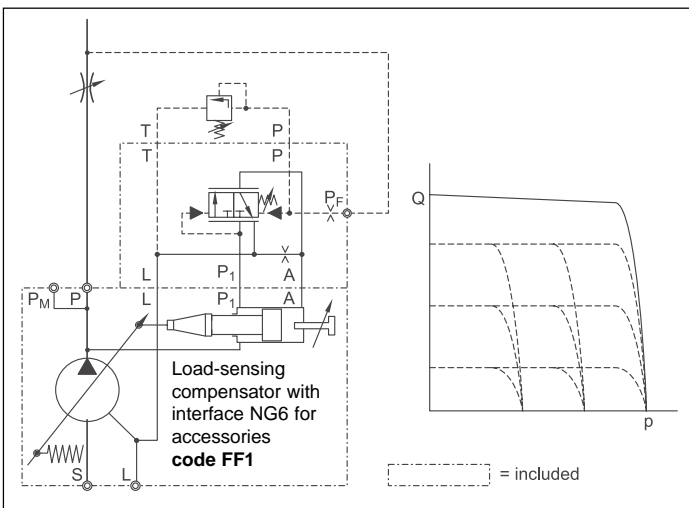

Shown is load sensing compensator code FF1

with an NG6 interface on top of the control valve. That allows direct mounting of a pilot valve for pressure compensation. This version includes the pilot orifice. Due to the interaction of flow and pressure compensation this package is not the "ideal" control characteristic. The deviation is caused by the pilot valves characteristic.

Horsepower Compensators

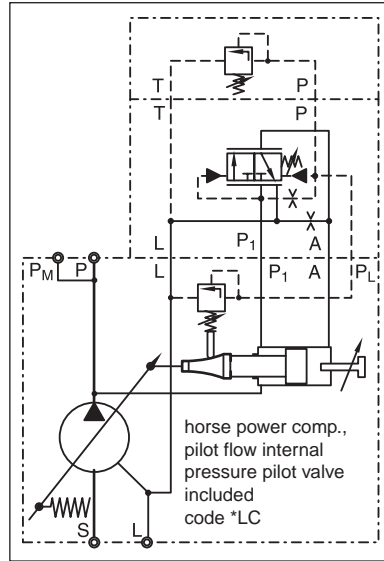
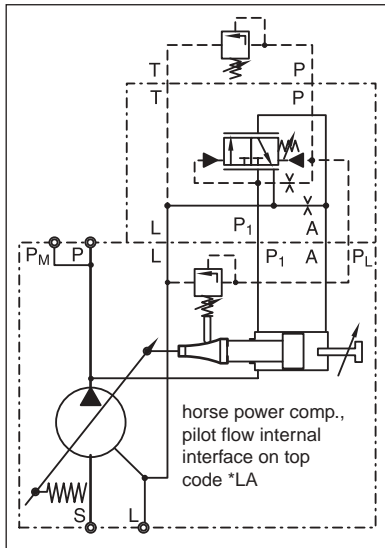

Hydraulic-mechanical horsepower compensator

The hydraulic-mechanical horsepower compensator consists of a modified remote pressure compensator (**Code *L***) and a pilot valve. This pilot valve is integrated into the pump and is adjusted by a cam sleeve. The cam sleeve has a contour that is designed and machined for the individual displacement and the nominal horsepower setting.

At a large displacement the opening pressure (given by the cam sleeve diameter) is lower than at small displacements. This makes the pump compensate along a constant horsepower (torque) curve.

For all nominal powers of standard electric motors Parker offers a dedicated cam sleeve. The exchange of this cam sleeve (e. g.: to change horsepower setting) can easily be done without disassembly of the pump.

On top of that an adjustment of the horsepower setting can be done within certain limits by adjusting the preload of the pilot control cartridge spring. That allows an adjustment of a constant horsepower setting for other than the nominal speeds (1500 RPM) or for other horsepower.

The ordering code for the horse power option is as follows:

The first digit designates the horsepower setting:

Code B = 5 HP etc. up to

Code 3 = 200 HP

The second digit designates the pilot flow source:

Code L internal pilot pressure, remote pressure function.

The third digit designates the possibility to adjust the overriding pressure compensation:

Code A comes with a top side NG6/D03 interface on the control valve to mount any suitable pilot valve or Parker pump accessories.

Code C includes a pilot valve for manual pressure adjustment. Max. setting: 350 bar (5075 PSI).

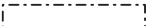
 = included

Noise Levels

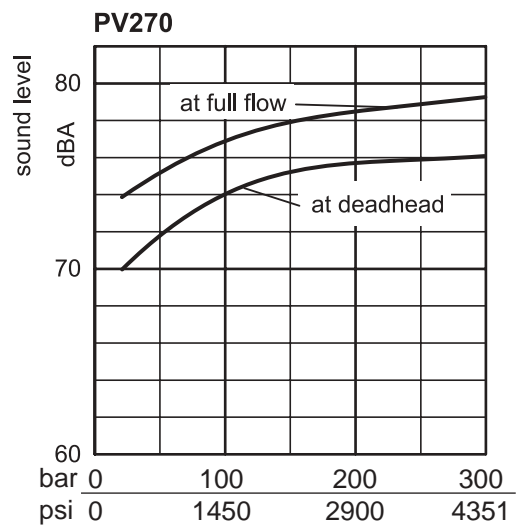
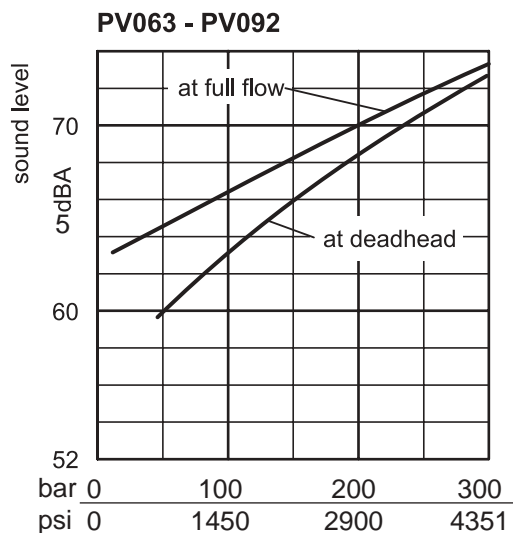
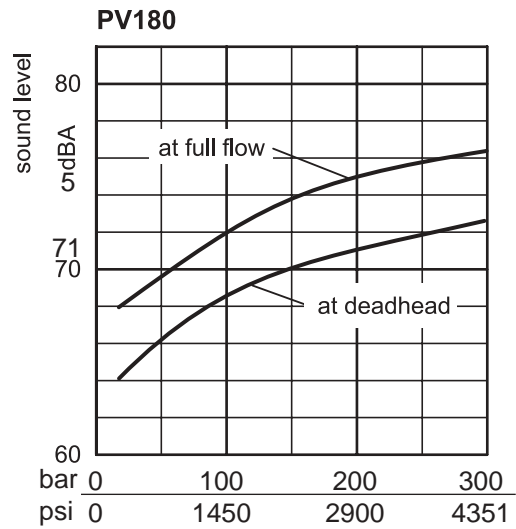
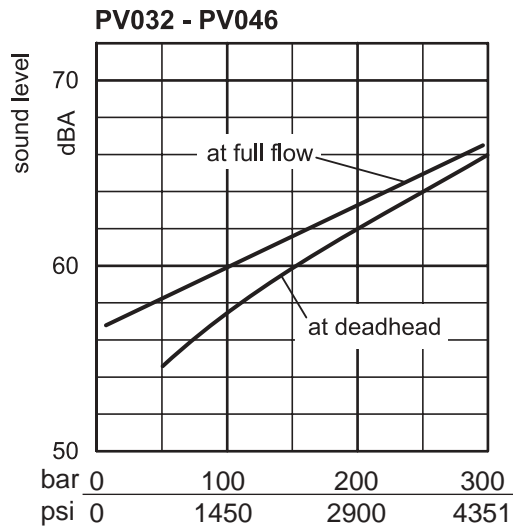
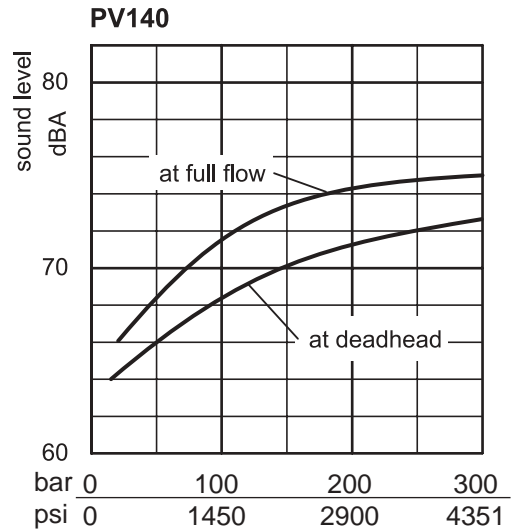
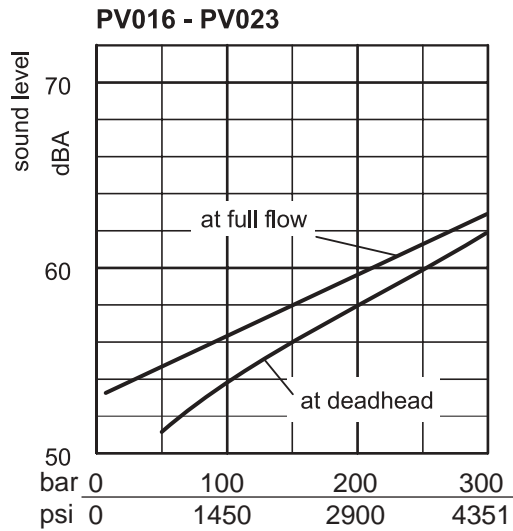

Typical sound level for single pumps, measured in anechoic chamber according to DIN 45 635, part 1 and 26. microphone distance 1 m. speed: $n = 1500 \text{ min}^{-1}$.

All data measured with mineral oil viscosity $30 \text{ mm}^2/\text{s}$ (cSt) at 50°C .

Noise reduction measures

Operating noise of pumps

The normal operating noise of a pump and consequently the operating noise of the entire hydraulic system is largely determined by **where** and **how** the pump is mounted and how it is connected to the downstream hydraulic system. Also size, style and installation of the hydraulic tubing have a major influence on the overall noise emitted by a hydraulic system.

Noise reduction measures

Talking about operating noise of a hydraulic pump, primary and secondary pump noise has to be taken into consideration.

Primary pump noise is caused by vibrations of the pump body due to internal alternating forces stressing the body structure.

Flexible elements help to prevent pump body vibration being transmitted to other construction elements, where possible amplification may occur. Such elements can be:

Bell housing with elastic dampening flange with vulcanized labyrinth (1)

Floating and flexible coupling (2)

Damping rails (3) or silent blocks for mounting the electric motor or the foot mounting flange

Flexible tube connections (compensators) or hoses on inlet, outlet and drain port of the pump.

Exclusive use of gas tight tube fittings for inlet connections to avoid ingress of air causing cavitation and excessive noise.

Secondary pump noise is caused by vibration induced into all connected hydraulic components by the flow and pressure pulsation of the pump. This secondary noise adds typical 7 - 10 dBA to the noise of a pump measured in the sound chamber according to DIN 45 635. Therefore pipework, its mounting and the mounting of all hydraulic components like pressure filters and control elements has a major influence to the overall system noise level.

Pulsation reduction with precompression volume: the PV is equipped with a new technology for flow ripple reduction. This method reduces the pulsation at the pump outlet by 40 - 60 %. That leads to a significant reduction of the overall system noise without additional cost and without additional components (silencers etc.). The typical reduction reaches 2 - 4 dBA. That means: with a pump of the PV series the secondary noise adds only some 5 - 7 dBA to the pump noise instead of the usually found 7 - 10 dBA.

Figure 2 compares the measured pulsation of a system with 6 pumps of 180 cm³/rev each.

Last, but not least the connection between pump and driving motor can be the cause of an unacceptably high noise emission.

Even when the mounting space is limited there are suitable means and components to reduce the noise significantly.

The vibration of the pump body, created by high alternating forces in the rotating group and the pulsation of the output flow excite every part of the system connected to the pump mechanically or hydraulically .

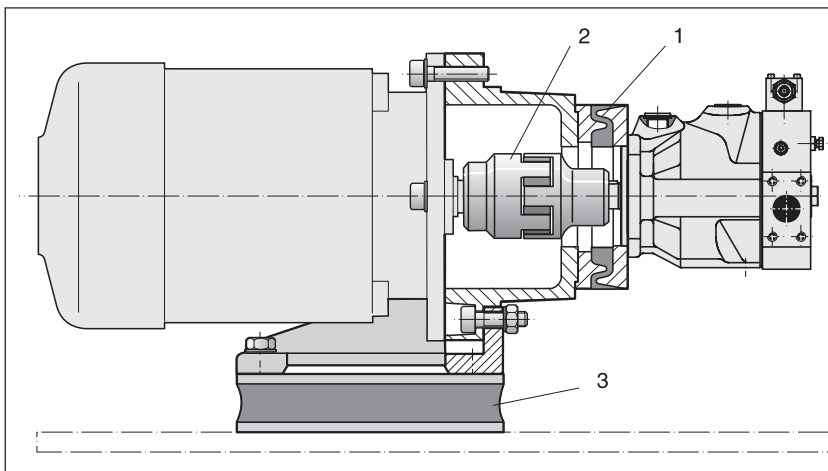

Figure 1: components to avoid vibration transfer from the pump to the drive/installation and their position in the power unit (numbers refer to the text on the left)

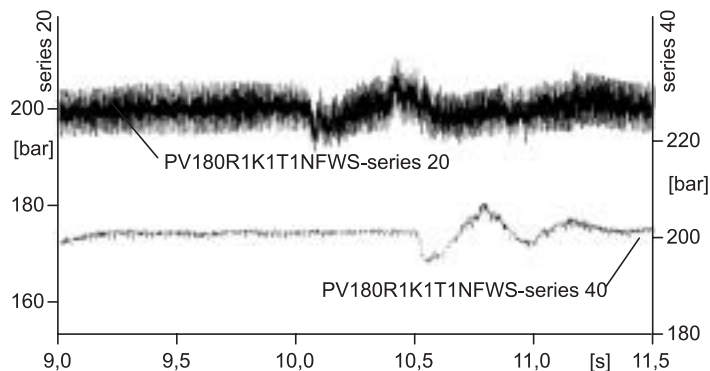

Figure 2: comparison of the pressure pulsation in a system with 6 old PV pumps versus the same system with 6 PVplus pumps. The pulsation reduction effect of the precompression volume is evident.

Other measures

Small diameter tubes do not only cause high flow speeds, turbulences inside the tubes and cavitation in the pump, they also produce noise.

Only correctly sized connections of the largest possible diameter according to the port size of the pump should be used.

Performance Information

Series PV, Pressure Compensated, Variable Volume, Piston Pumps

Features

- High Strength Cast-Iron Housing for high reliability and quiet operation
- Modular Controls for field convertability
- Large Control Piston for fast response
- Thru-Shaft Option with 100% thru torque capability
- Multiple Pressure Control with valves mounted directly on pump
- Pre-Compression chamber to minimize over-all system noise

Controls

- Pressure Compensation
- Remote Pressure Compensation
- Load Sensing
- Adjustable Maximum Volume Stop
- Electrohydraulic Pressure
- Dual and Tri-Pressure Control
- Low Pressure Standby
- Horsepower Limiting

Schematic Symbol

(Basic Pump)

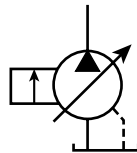

Installation Data

See Installation Information on page A156 of this catalog for specific recommendations pertaining to system cleanliness, fluids, start-up, inlet conditions, shaft alignment, drain line restrictions and other important factors relative to the proper installation and use of these products.



Specifications

Pressure Ratings: 5000 PSI (350 bar) Continuous
 6000 PSI (420 bar) Peak

Speed Ratings: 600 to 2750 RPM

Inlet Condition: 230 PSI (16 bar)
 Maximum Inlet Charge
 5 In. Hg. Max. Vacuum at
 1800 RPM

Case Drain Conditions: 7 PSI (0.5 bar) Maximum

Operating Temp. Range: -40°F to 160°F
 (-40°C to 70°C)

Housing Material: Cast Iron

Filtration: Maintain SAE Class 4 (ISO 16/13)

Mounting: SAE "B" 4-Bolt Flange

Quick Reference Data Chart

Pump Model	Displacement cc/rev (in ³ /rev)	Pump Delivery @ 7 bar (100 PSI) in LPM (GPM)		*Approx. Noise Levels dB(A) @ Full Flow and 1500 RPM			Input Power At 1800 RPM, Max. Displacement & 343 bar (5000 PSI)	Max. Operating Speed (RPM)
		1200 RPM	1800 RPM	70 bar (1000 PSI)	207 Bar (3000 PSI)	343 bar (5000 PSI)		
PV016	16 (.98)	19.2 (5.1)	28.8 (7.6)	56	60	68	18.5 kw (24.8 hp)	2750
PV020	20 (1.2)	24.0 (6.3)	36.0 (9.5)	56	60	68	23.4 kw (31.4 hp)	2750
PV023	23 (1.4)	27.6 (7.3)	41.4 (10.9)	56	60	68	25.1 kw (33.6 hp)	2750

* The noise level values are based on anechoic room measurements at a distance of 1 meter in accordance with DIN 45645.

Performance Curves

Fluid: Standard Hydraulic Oil 100 SSU @ 120°F (49°C)

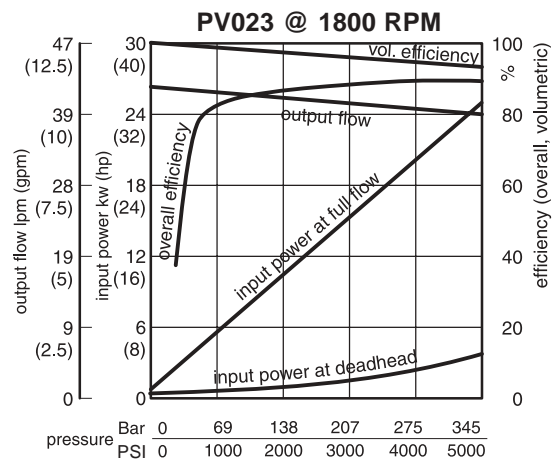
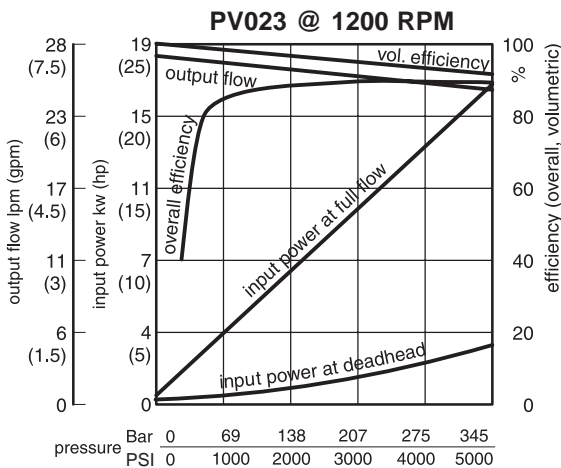
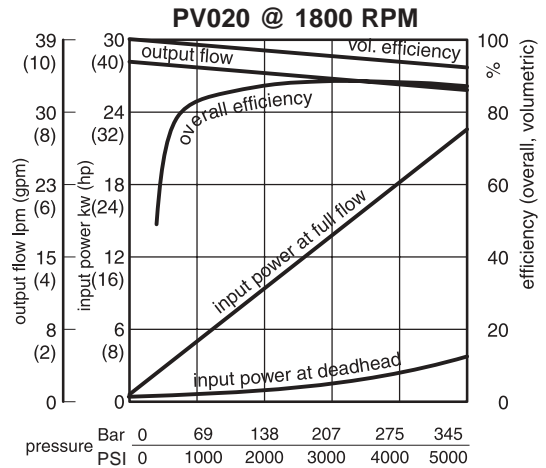
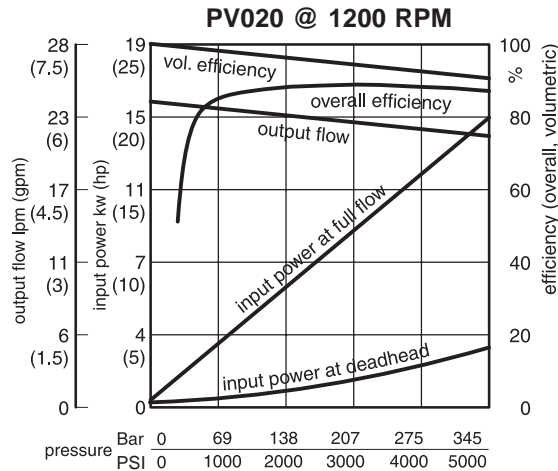
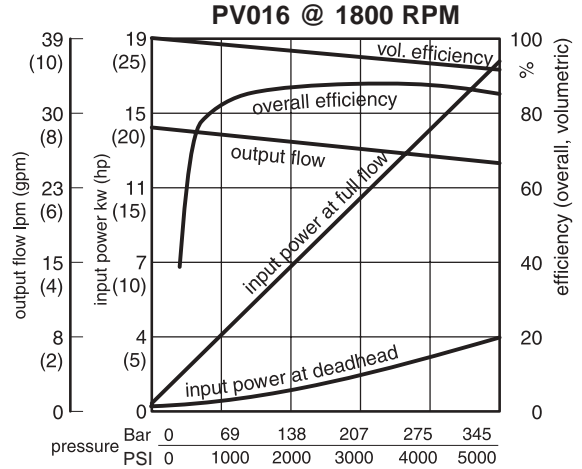
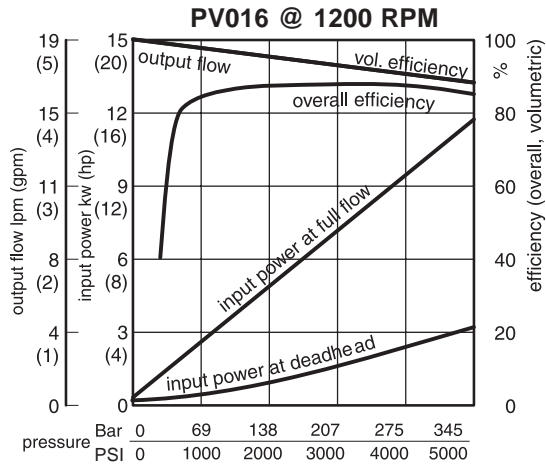

NOTE: The efficiencies and data in the graphs are good only for pumps running at speeds shown and stroked to maximum. To calculate approximate horsepower for the other conditions, use the following formula:

$$HP = \left[\frac{Q \times (PSI)}{1714} \right] + (CHp)$$

Actual GPM is directly proportional to drive speed and

maximum volume setting. Flow loss, however, is a function of pressure only.

WHERE:

Q = Actual Output Flow in GPM

PSI = Pressure At Pump Outlet

CHp = Input Horsepower @ Full compensation @ 1800 RPM (from graph read at operating pressure)

mounting hole for horse power compensator pilot or displacement feedback LVDT

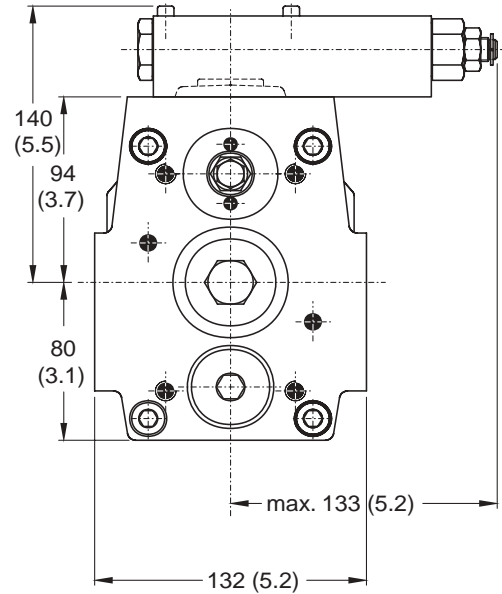
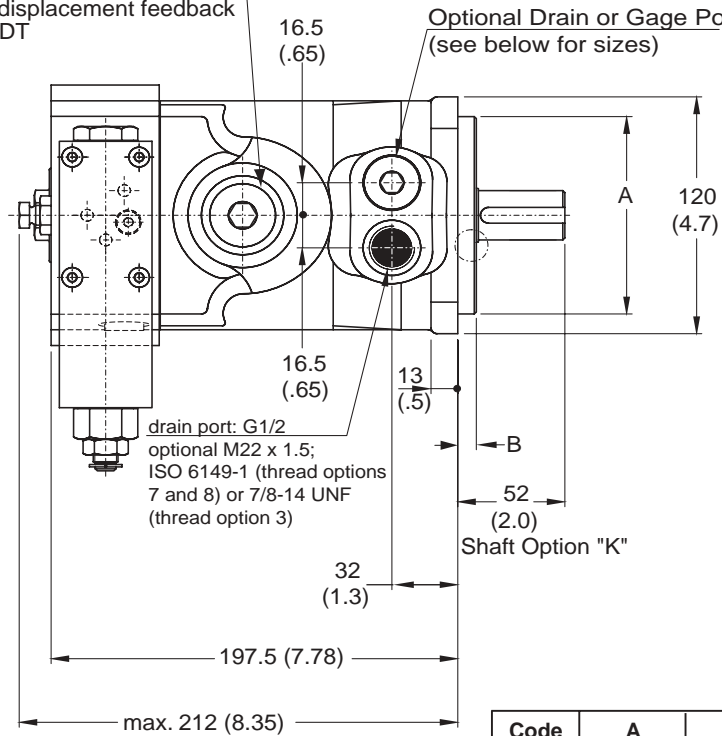

View X
 Shown with standard pressure compensator

Code	A	B	ØC
D,E	4.0"	.37"	5.0"
K,L	100mm	9mm	125mm

Adjustable Vol. Stop
 1.5 cc/rev Per Rev.

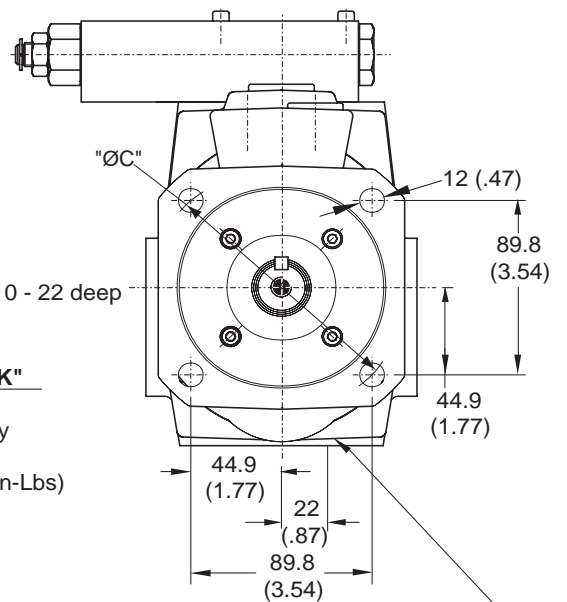
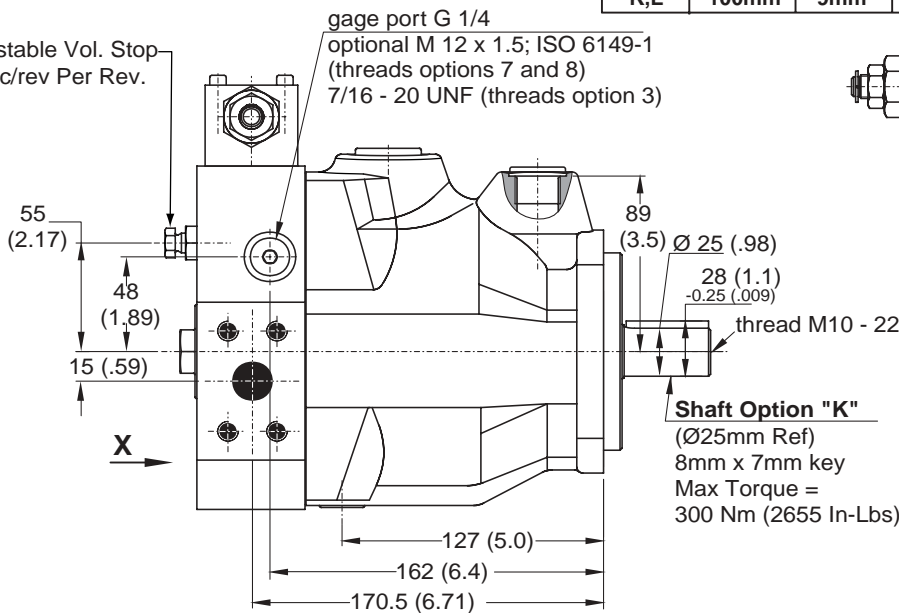

flushing port; G 3/8
 optional M 18 x 1.5; ISO 6149-1 (threads options 7 and 8) or 3/4 - 16 UNF (thread option)

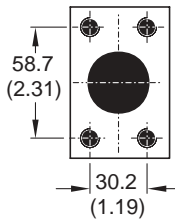

Inlet:
Option 3 & 7
 1-1/4" 4 Bolt Flange
 7/16-14 UNC-2B Threads
Option 1 & 8
 32mm 4 Bolt Flange
 M10 Threads
 Standard Pressure Series
 (Code 61)

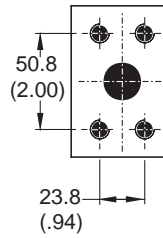

Outlet:
Option 3 & 7
 3/4" 4 Bolt Flange
 3/8-16 UNC-2B Threads
Option 1 & 8
 19mm 4 Bolt Flange
 M10 Threads
 High Pressure Series (Code 62)

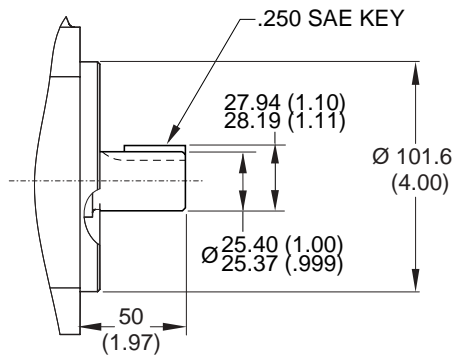

Shaft Option "D"
 (SAE "BB")
 Max Torque= 300 Nm (2655 In-Lbs)

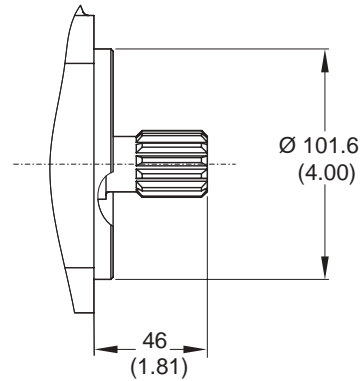

Shaft Option "E"
 (SAE "BB")
 15 Teeth 16/32 Pitch
 30° Involute Spline
 Max Torque= 300 Nm (2655 In-Lbs)

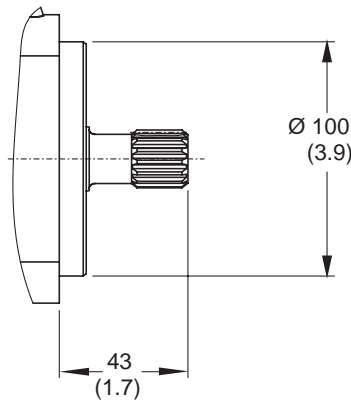

Shaft Option "L"
 W25mm x 1.5mm x 15mm x 8f
 DIN 5480
 Max Torque = 405 Nm (3584 In-Lbs)

Thru-Shaft Options

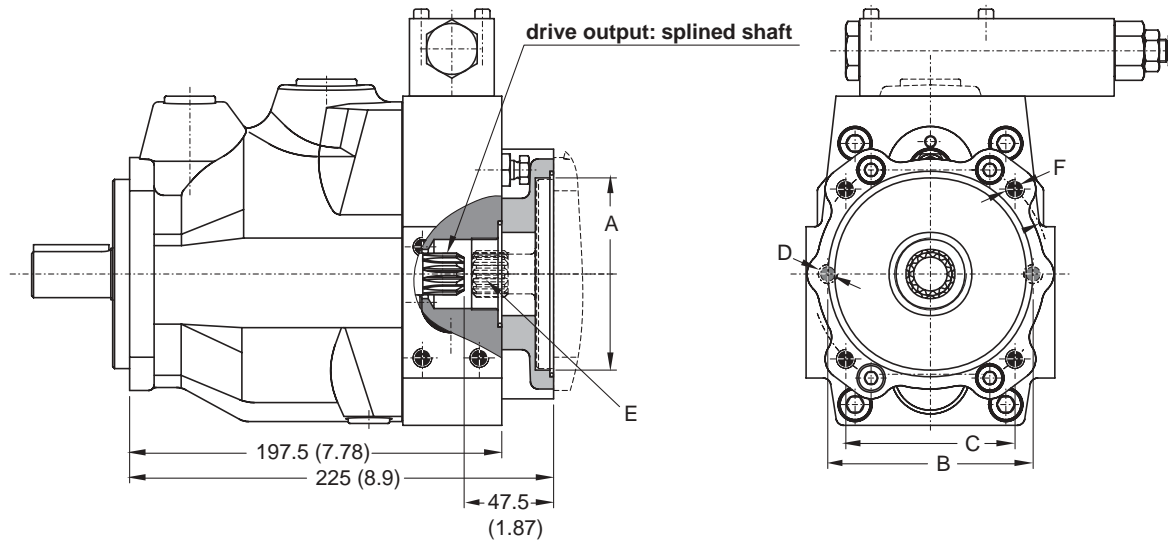

Thru-Shaft Load Limitations

The maximum allowable torque of the individual shaft must not be exceeded. For 2-pump combinations there is no problem because the PV series offers 100% thru torque capabilities. For 3-pump combinations or more the limit torque could be reached or exceeded. Therefore it is necessary to calculate the torque factor and compare the sum of each pumps torque factor to the table to make sure it does not exceed the torque limit factor.

Pump	Shaft	Torque Limit Factor
PV016-023	D	17700
	E	17700
	K	17700
	L	20130

Required: Sum of all calculated torque factors must be <torque limit factor.

Torque factor of any pump =
 Pressure (bar) x Displacement (cc/rev)

Code	A	B	C	D	E*	F
A7	Ø3.25"	4.188"	-	3/8"-16	SAE "A" 9T 16/32 DP SPLINE	-
B3	Ø4.00"	-	3.536"	-	SAE "B" 13T 16/32 DP SPLINE	1/2"-13
J3	Ø100mm	-	44mm	-	W25 X 1.5 X 8f SPLINE	M10
W3	Ø4.00"	-	3.536"	-	SAE "BB" 15T 16/32 DP SPLINE	1/2"-13
Y7	Ø2.00"	3.250"	-	5/16-18	SAE "AA" 1/2" KEYED	-

*Coupling included with pump when ordered from Greenville, TN.

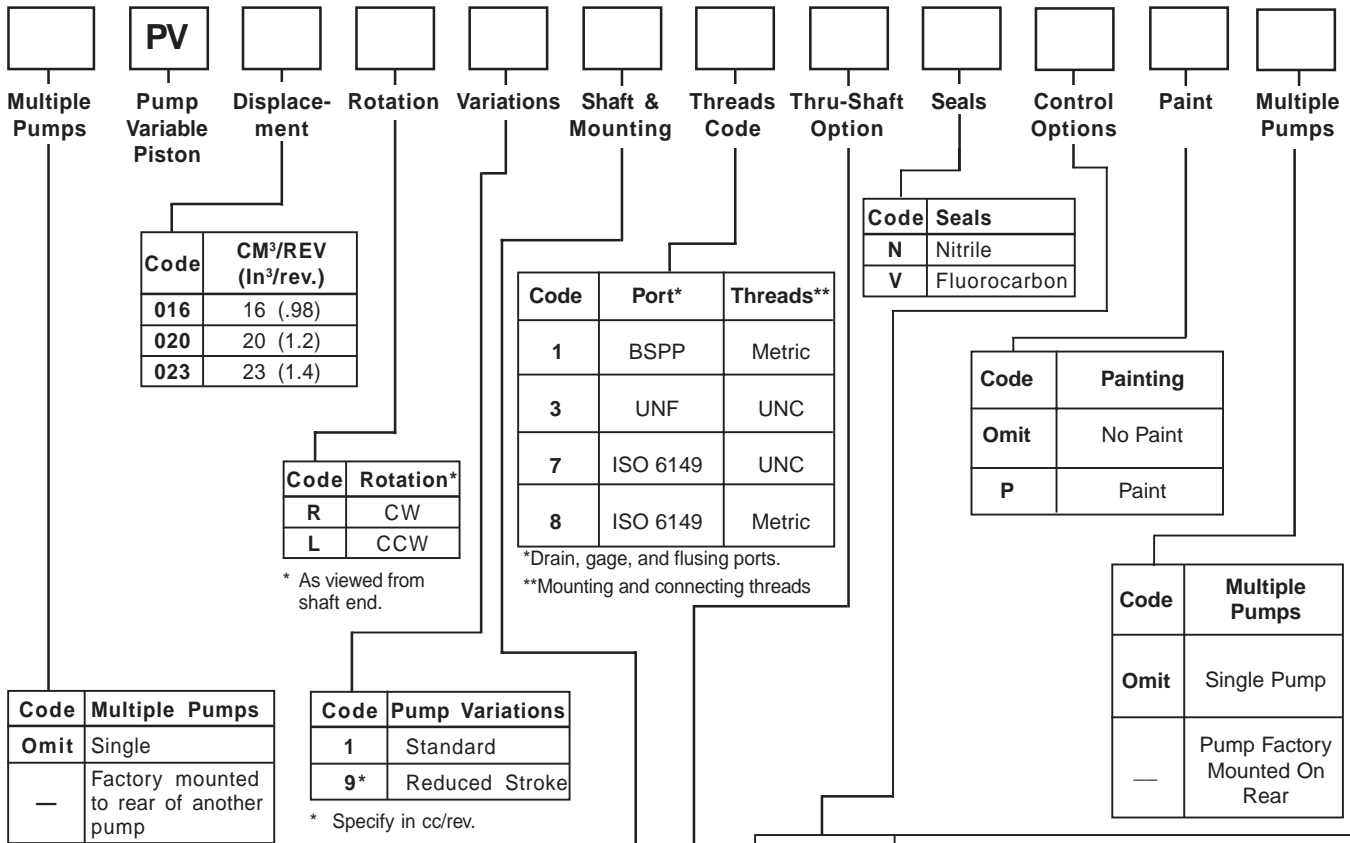

Code	Shaft	Pilot
D	1" Keyed (SAE BB)	4 Bolt SAE "B"
E	15T Spline (SAE BB)	4 Bolt SAE "B"
K	25mm Keyed	4 Bolt 100mm
L	W25 x 1.5 x 15 x 8f Spline DIN 5480	4 Bolt 100mm

Code	Thru-Shaft Option
T1	Thru-Shaft Capable, Single Pump w/Cover
Y7	2 Bolt SAE "AA" Pilot 2.00/SAE "AA" 1/2" Keyed
A7	2 Bolt SAE "A" Pilot 3.25/SAE "A" 9T 16/32 DP
B3	4 Bolt SAE "B" Pilot 4.00/SAE "B" 13T 16/32 DP
J3*	4 Bolt 100mm Pilot/W25x1.5x15x8f Spline DIN 5480
W3	4 Bolt SAE "B" Pilot 4.00/SAE "BB" 15T 16/32 DP

*Must be used with port/thread option 1.

Code	Control Options
F	Standard Pressure Compensator
S	Adjustment Type
W	Pressure Range
H	Pressure Range
D	Pressure Range
F	Remote/Load Sense Compensator
1	Control Port
Z	Control Port
R	Compensator Control Type
F	Compensator Control Type
L	Horsepower Compensator Control
A	Control Port
C	Control Port
Z	Control Port
B	Input Horsepower at 1800 RPM
C	Input Horsepower at 1800 RPM
D	Input Horsepower at 1800 RPM
E	Input Horsepower at 1800 RPM
G	Input Horsepower at 1800 RPM

* Maximum pressure adjustment not included, but recommended. (See PVAC Section)

** Valve to be mounted at factory must be ordered as a separate line item. Consult factory. See PVAC section for pressure valve options.



Performance Information

Series PV, Pressure Compensated, Variable Volume, Piston Pumps

Features

- High Strength Cast-Iron Housing for high reliability and quiet operation
- Modular Controls for field convertability
- Large Control Piston for fast response
- Thru-Shaft Option with 100% thru torque capability
- Multiple Pressure Control with valves mounted directly on pump
- Pre-Compression chamber built in to minimize over-all system noise

Controls

- Pressure Compensation
- Remote Pressure Compensation
- Load Sensing
- Adjustable Maximum Volume Stop
- Electrohydraulic Pressure
- Dual and Tri-Pressure Control
- Low Pressure Standby
- Horsepower Limiting

Schematic Symbol

(Basic Pump)

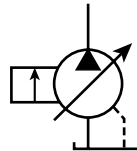

Installation Data

See Installation Information on page A156 of this catalog for specific recommendations pertaining to a system cleanliness, fluids, start-up, inlet conditions, shaft alignment, drain line restrictions and other important factors relative to the proper installation and use of these products.



Specifications

Pressure Ratings: 5000 PSI (350 bar) Continuous
 6000 PSI (420 bar) Peak

Speed Ratings: 600 to 2400 RPM

Inlet Condition: 230 PSI (16 bar)
 Maximum Inlet Charge
 5 In. Hg. Max. Vacuum at
 1800 RPM

Case Drain Conditions: 7 PSI (0.5 bar) Maximum

Operating Temp. Range: -40°F to 160°F
 (-40°C to 70°C)

Housing Material: Cast Iron

Filtration: Maintain SAE Class 4 (ISO 16/13)

Mounting: SAE "C" 4-Bolt Flange

Quick Reference Data Chart

Pump Model	Displacement cc/rev (in ³ /rev)	Pump Delivery @ 7 bar (100 PSI) in LPM (GPM)		*Approx. Noise Levels dB(A) @ Full Flow and 1500 RPM			Input Power At 1800 RPM, Max. Displacement & 343 bar (5000 PSI)	Max. Operating Speed (RPM)
		1200 RPM	1800 RPM	70 bar (1000 PSI)	207 bar (3000 PSI)	343 bar (5000 PSI)		
PV032	32 (1.9)	38.4 (10.1)	57.6 (15.2)	59	62	69	35.1 kw (47.0 hp)	2400
PV040	40 (2.4)	48.0 (12.7)	72.0 (19.0)	59	62	69	46.5 kw (62.4 hp)	2400
PV046	46 (2.8)	55.2 (14.6)	82.8 (21.9)	59	62	69	50.2 kw (67.3 hp)	2400

* The noise level values are based on anechoic room measurements at a distance of 1 meter in accordance with DIN 45645.

Performance Curves Fluid: Standard Hydraulic Oil 100 SSU @ 120°F (49°C)

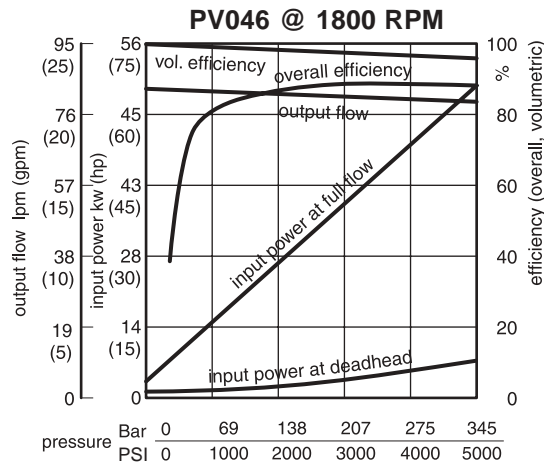
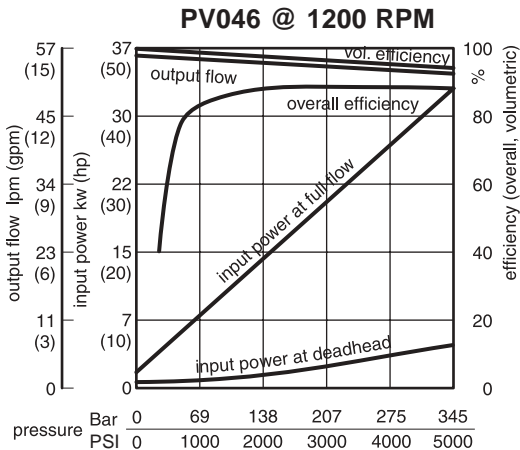
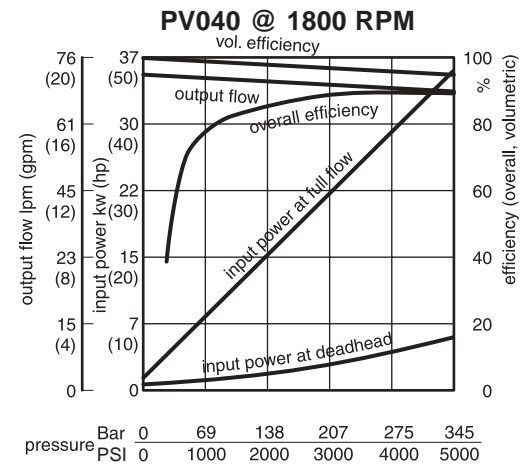
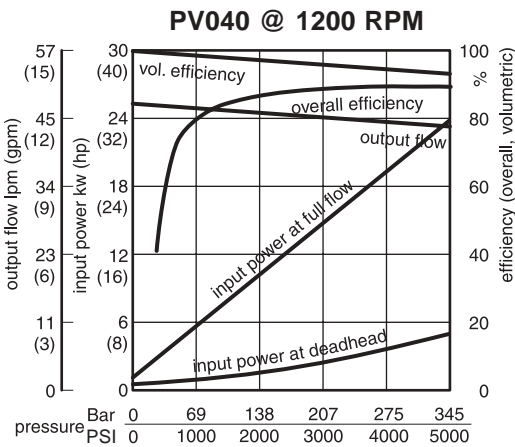
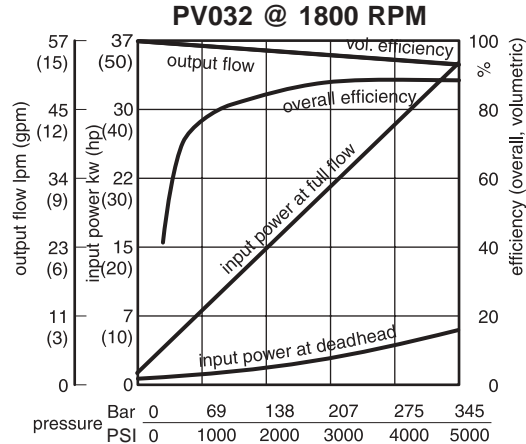
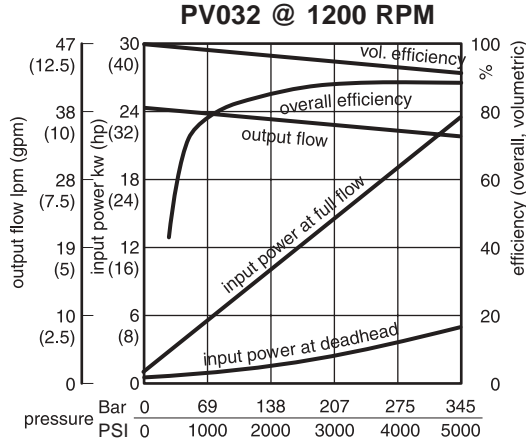

NOTE: The efficiencies and data in the graphs are good only for pumps running at speeds shown and stroked to maximum. To calculate approximate horsepower for the other conditions, use the following formula:

$$HP = \left[\frac{Q \times (PSI)}{1714} \right] + (CHp)$$

Actual GPM is directly proportional to drive speed and

maximum volume setting. Flow loss, however, is a function of pressure only.

WHERE:

Q = Actual Output Flow in GPM

PSI = Pressure At Pump Outlet

CHp = Input Horsepower @ Full compensation @ 1800 RPM (from graph read at operating pressure)

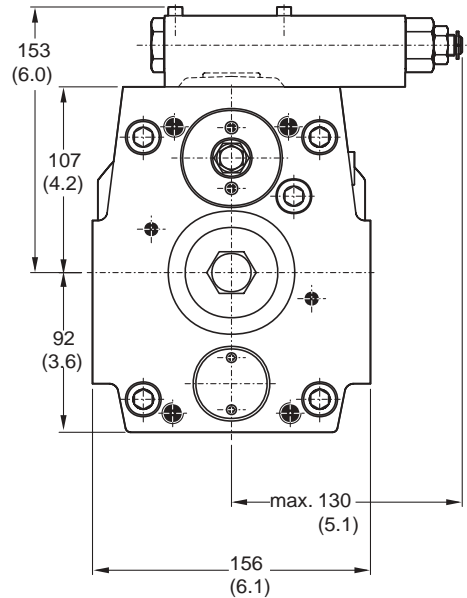
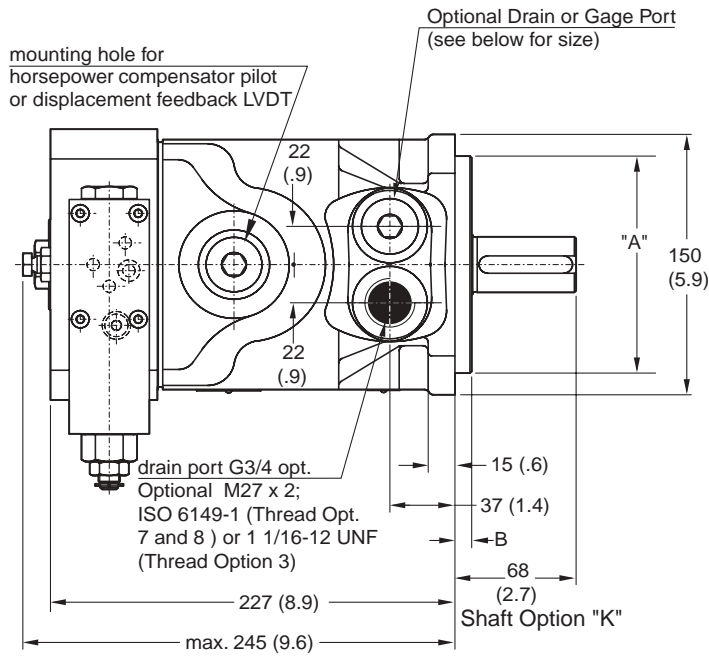

View X

Shown with standard pressure compensator

Code	A	B	ØC
D,E	5.0"	.50"	6.37"
K,L	125mm	9mm	160mm

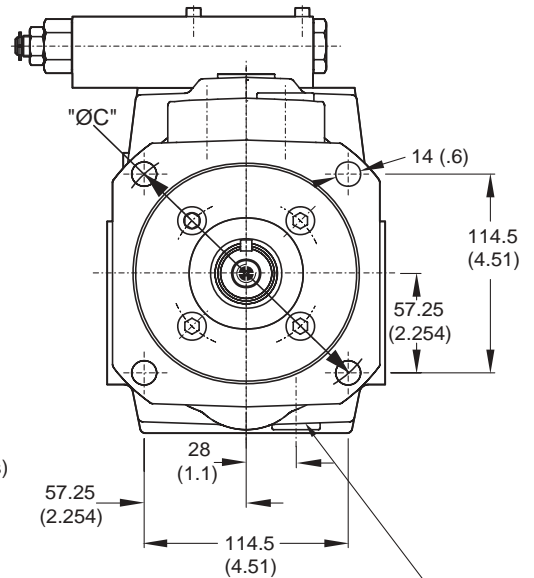
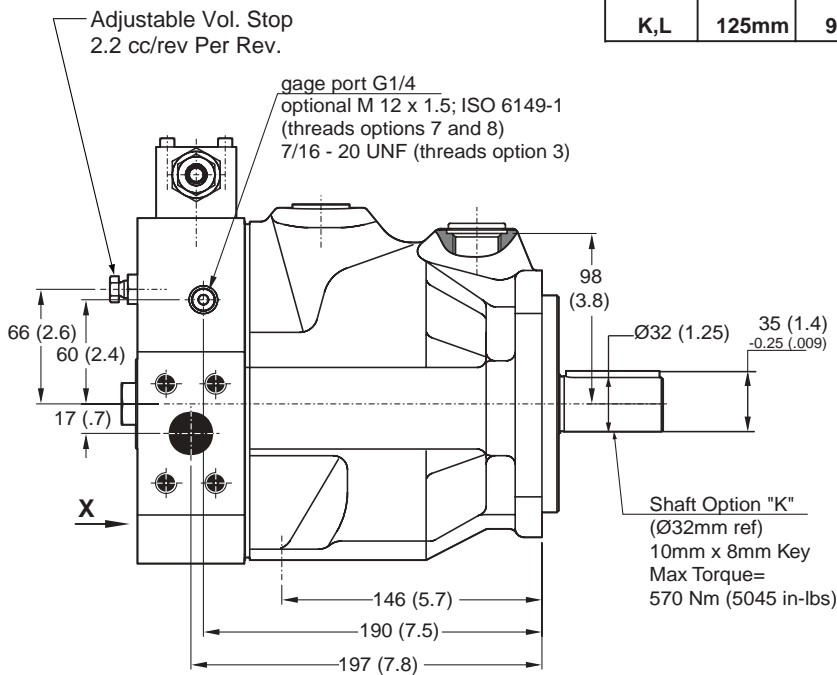

flushing port G1/2
optional M 22 x 1.5; ISO 6149-1 (threads options 7 and 8)
or 7/8 - 14 UNF (threads option 3)

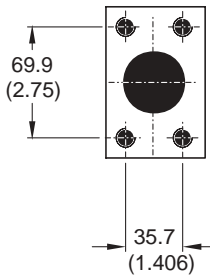

Inlet:
Option 3 & 7
 1-1/2" 4 Bolt Flange
 1/2-13 UNC-2B Threads
Option 1 & 8
 35mm 4 Bolt Flange
 M12 Threads
 Standard Pressure Series
 (Code 61)

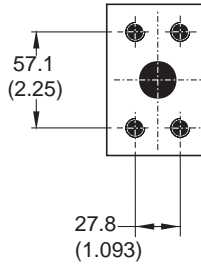

Outlet:
Option 3 & 7
 1" 4 Bolt Flange
 7/16-14 UNC-2B Threads
Option 1 & 8
 25mm 4 Bolt Flange
 M12 Threads
 High Pressure Series (Code 62)

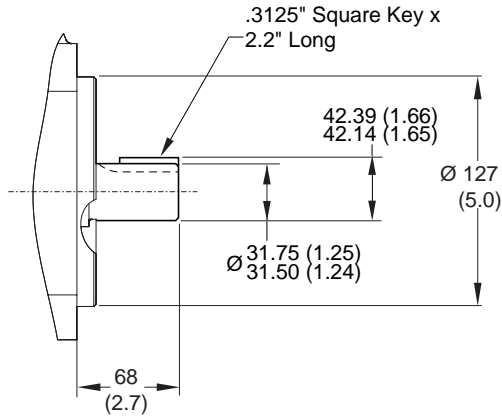

Shaft Option "D"
 (SAE "C")
 Max Torque= 550 Nm (4868 In-Lbs)

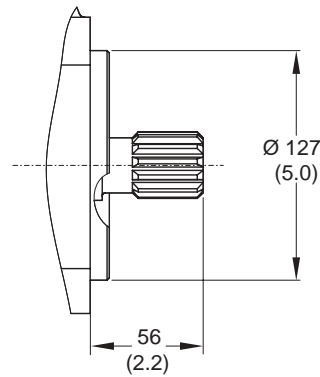

Shaft Option "E"
 (SAE "C")
 14 Teeth 12/24 Pitch
 30° Involute Spline
 Max Torque= 610 Nm (5399 In-Lbs)

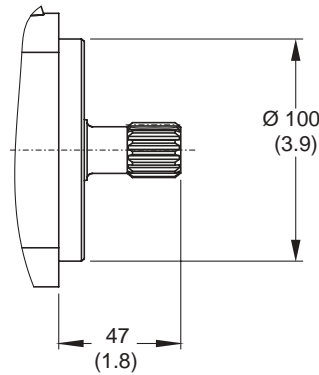

Shaft Option "L"
 W32mm x 1.5mm x 20mm x 8f
 DIN 5480
 Max Torque = 675 Nm (5974 In-Lbs)

Thru-Shaft Options

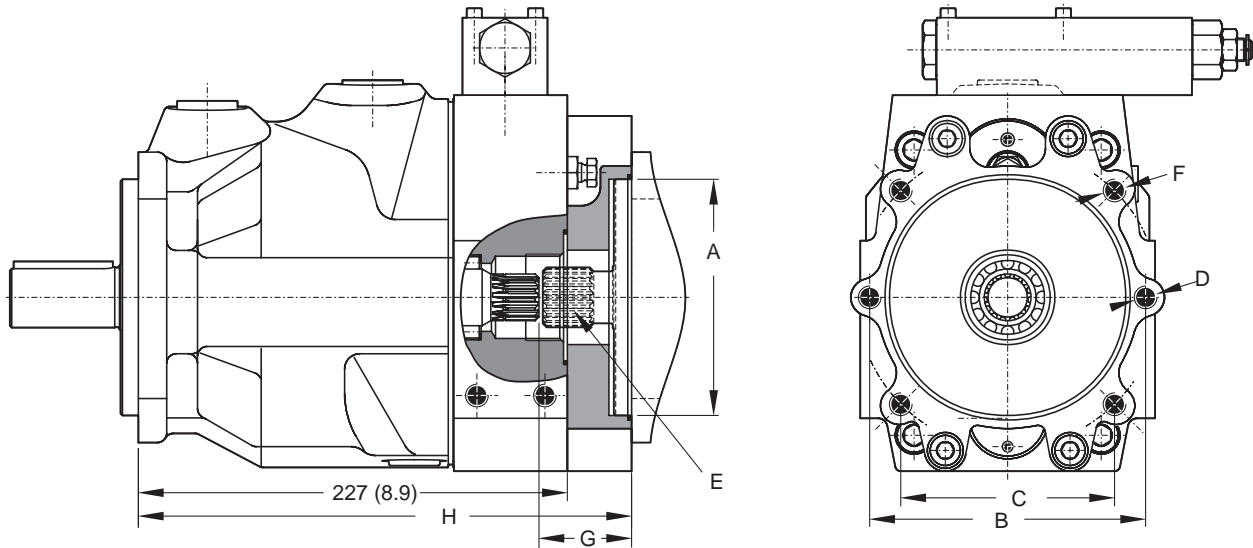

Thru-Shaft Load Limitations

The maximum allowable torque of the individual shaft must not be exceeded. For 2-pump combinations there is no problem because the PV series offers 100% thru torque capabilities. For 3-pump combinations or more the limit torque could be reached or exceeded. Therefore it is necessary to calculate the torque factor and compare the sum of each pumps torque factor to the table to make sure it does not exceed the torque limit factor.

Pump	Shaft	Torque Limit Factor
PV032-046	D	32680
	E	36380
	K	33810
	L	40250

Required: Sum of all calculated torque factors must be <torque limit factor.

Torque factor of any pump =
 Pressure (bar) x Displacement (cc/rev)

Code	A	B	C	D	E*	F	G	H
A7	Ø3.25"	4.188"	-	3/8"-16	SAE "A" 9T 16/32 DP SPLINE	-	1.93"	10.27"
B3	Ø4.00"	-	3.536"	-	SAE "B" 13T 16/32 DP SPLINE	1/2"-13	1.93"	10.27"
B7	Ø4.00"	5.750"	-	1/2"-13	SAE "B" 13T 16/32 DP SPLINE	-	1.93"	10.27"
W3	Ø4.00"	-	3.530"	-	SAE "BB" 15T 16/32 DP SPLINE	1/2"-13	1.93"	10.27"
W7	Ø4.00"	5.750"	-	1/2"-13	SAE "BB" 15T 16/32 DP SPLINE	-	1.93"	10.27"
C3	Ø5.00"	-	4.508"	-	SAE "C" 14T 12/24 DP SPLINE	1/2"-13	2.52"	10.87"
J3	Ø100mm	-	44mm	-	W25 x 1.5 x 15 x 8f SPLINE	M10	1.93"	10.27"
K3	Ø125mm	-	57mm	-	W32 x 1.5 x 20 x 8f SPLINE	M12	1.93"	10.27"

*Coupling included with pump if ordered from Greenville, TN

Ordering Information

**Variable Volume Piston Pumps
Series PV 032/040/046**

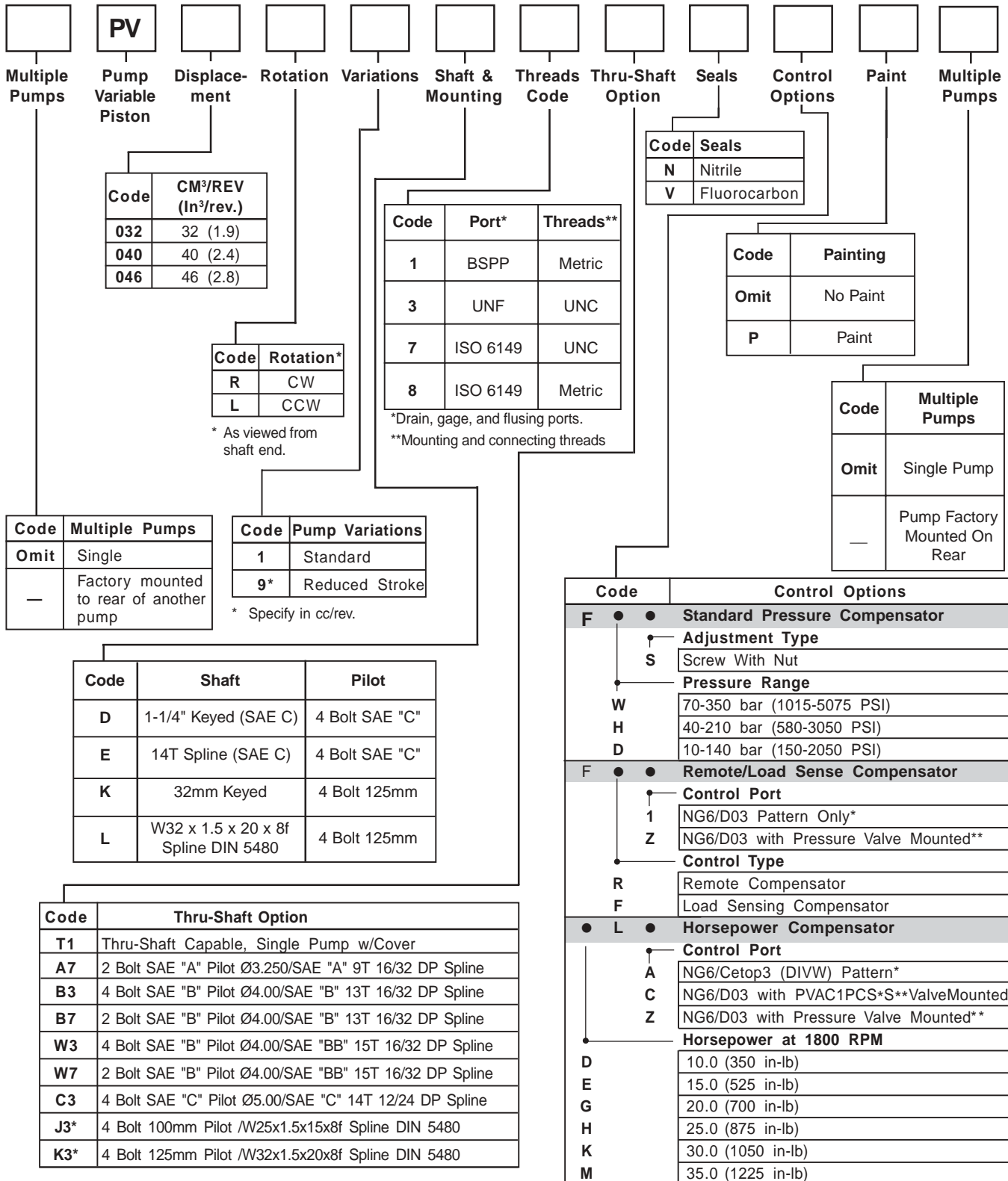

*Must be used with port/thread option 1

* Maximum pressure adjustment for pump not included, but necessary. See PVAC section for pressure valve options.

** Valve to be mounted at factory must be ordered as a separate line item. Consult factory. See PVAC section for pressure valve options.

Performance Information

Series PV, Pressure Compensated, Variable Volume, Piston Pumps

Features

- High Strength Cast-Iron Housing for high reliability and quiet operation
- Modular Controls for field convertability
- Large Control Piston for fast response
- Thru-Shaft Option with 100% thru torque capability
- Multiple Pressure Control with valves mounted directly on pump
- Pre-Compression chamber to minimize over-all system noise

Controls

- Pressure Compensation
- Remote Pressure Compensation
- Load Sensing
- Adjustable Maximum Volume Stop
- Electrohydraulic Pressure Control
- Dual and Tri-Pressure
- Low Pressure Standby
- Horsepower Limiting

Schematic Symbol

(Basic Pump)

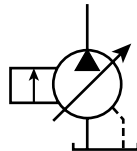

Installation Data

See Installation Information on page A156 of this catalog for specific recommendations pertaining to system cleanliness, fluids, start-up, inlet conditions, shaft alignment, drain line restrictions and other important factors relative to the proper installation and use of these products.



Specifications

Pressure Ratings: 5000 PSI (350 bar) Continuous
 6000 PSI (420 bar) Peak

Speed Ratings: 600 to 2400 RPM (PV063)
 600 to 2300 RPM (PV080)
 600 to 2200 RPM (PV092)

Inlet Conditions: 230 PSI (16 bar)
 Maximum Inlet Charge
 5 In. Hg. Max. Vacuum at
 1800 RPM

Case Drain Conditions: 7 PSI (0.5 bar) Maximum

Operating Temp. Range: -40°F to 160°F
 (-40°C to 70°C)

Housing Material: Cast Iron

Filtration: Maintain SAE Class 4 (ISO 16/13)

Mounting: SAE "D" 4-Bolt Flange

Quick Reference Data Chart

Pump Model	Displacement cc/rev (in ³ /rev)	Pump Delivery @ 7 bar (100 PSI) in LPM (GPM)		*Approx. Noise Levels dB(A) @ Full Flow and 1500 RPM			Input Power At 1800 RPM, Max. Displacement & 343 bar (5000 PSI)	Max. Operating Speed (RPM)
		1200 RPM	1800 RPM	70 bar (1000 PSI)	207 bar (3000 PSI)	343 bar (5000 PSI)		
PV063	63 (3.8)	75.6 (20.0)	113.4 (30.0)	66	70	74	70.1 kw (94.0 hp)	2400
PV080	80 (4.8)	96.0 (25.4)	144.0 (38.0)	66	70	74	89.2 kw (119.6 hp)	2300
PV092	92 (5.6)	110.4 (29.2)	165.6 (43.8)	66	70	74	136.8 kw (183.5 hp)	2200

* The noise level values are based on anechoic room measurements at a distance of 1 meter in accordance with DIN 45645.

Performance Curves

Fluid: Standard Hydraulic Oil 100 SSU @ 120°F (49°C)

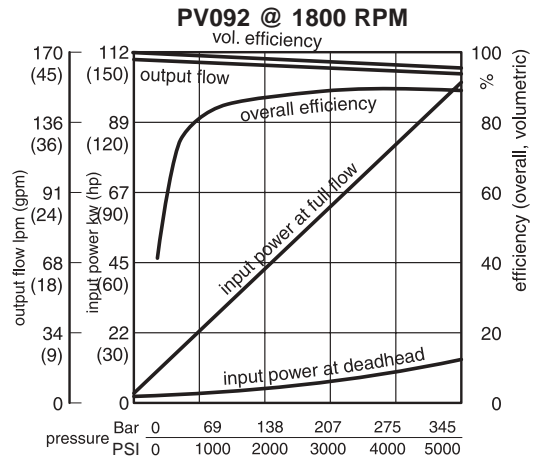
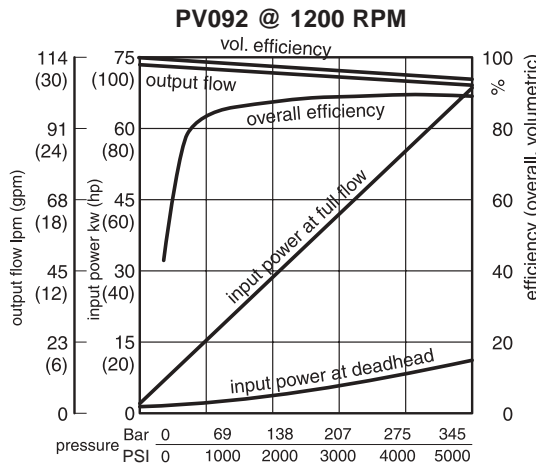
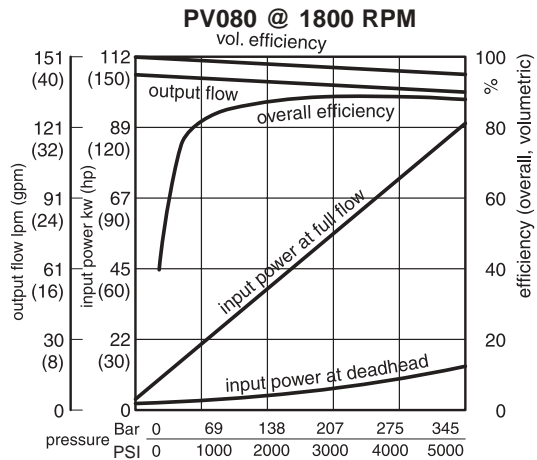
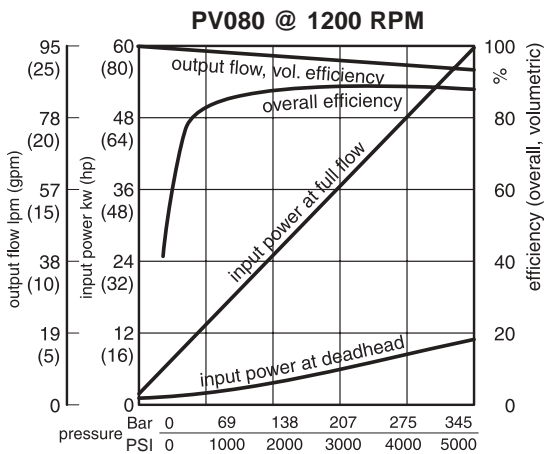
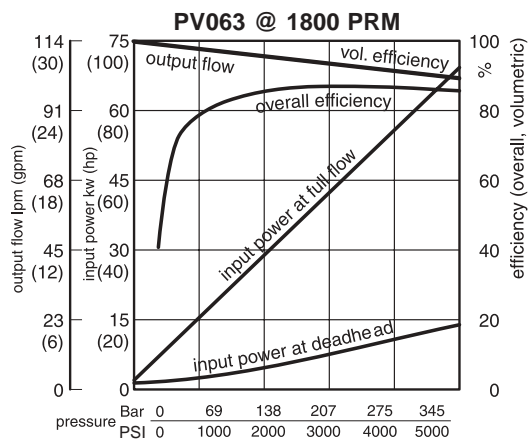
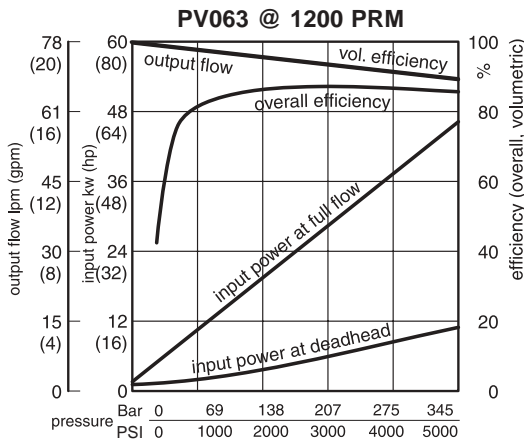

NOTE: The efficiencies and data in the graphs are good only for pumps running at speeds shown and stroked to maximum. To calculate approximate horsepower for the other conditions, use the following formula:

$$HP = \left[\frac{Q \times (PSI)}{1714} \right] + (CHp)$$

Actual GPM is directly proportional to drive speed and

maximum volume setting. Flow loss, however, is a function of pressure only.

WHERE:

Q = Actual Output Flow in GPM

PSI = Pressure At Pump Outlet

CHp = Input Horsepower @ Full compensation @ 1800 RPM (from graph read at operating pressure)

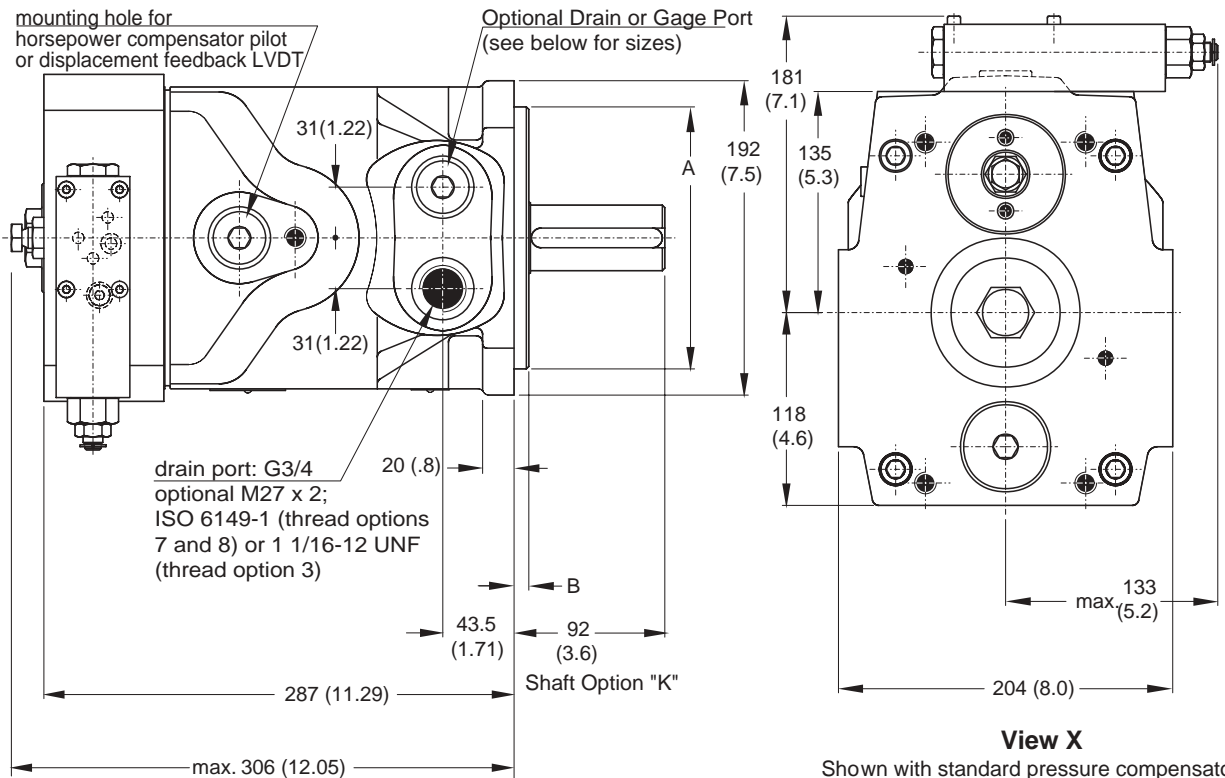

Code	A	B	ØC	ØD
D,E	6.00"	.50"	9.00"	.81"
K,L	160mm	9mm	200mm	18mm

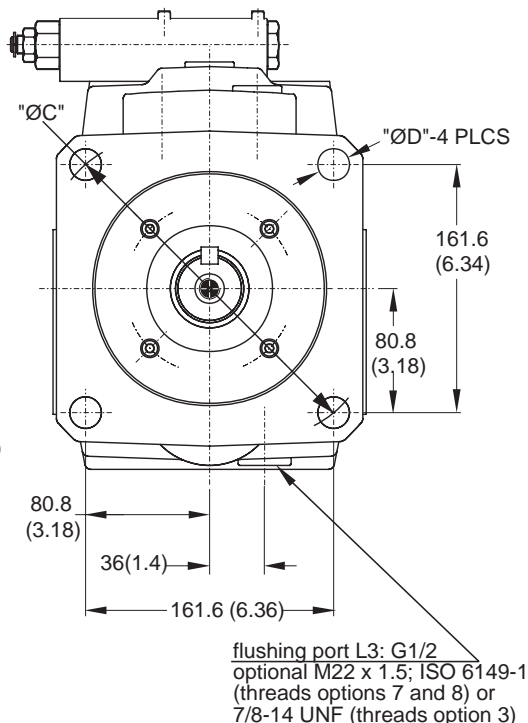
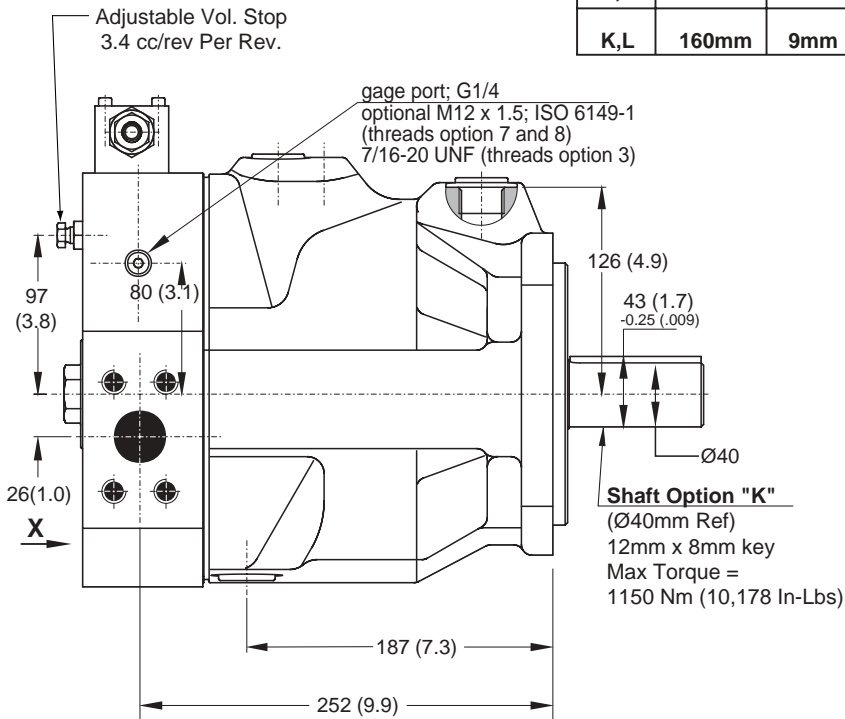

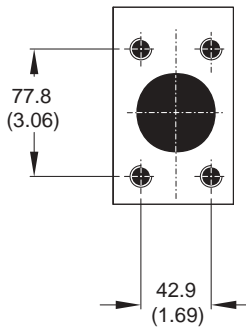

Inlet:
Option 3 & 7
 2" 4 Bolt Flange
 1/2-13 UNC-2B Threads
Option 1 & 8
 50mm 4 Bolt Flange
 M12 Threads
 Standard Pressure Series
 (Code 61)

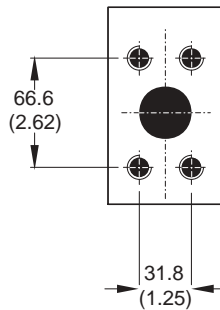

Outlet:
Option 3 & 7
 1-1/4" 4 Bolt Flange
 1/2-13 UNC-2B Threads
Option 1 & 8
 32mm 4 Bolt Flange
 M12 Threads
 High Pressure Series (Code 62)

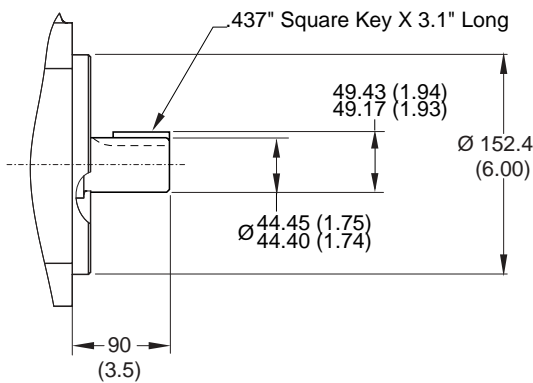

Shaft Option "D"
 (SAE "D")
 Max Torque= 1320 Nm (11,683 In-Lbs)

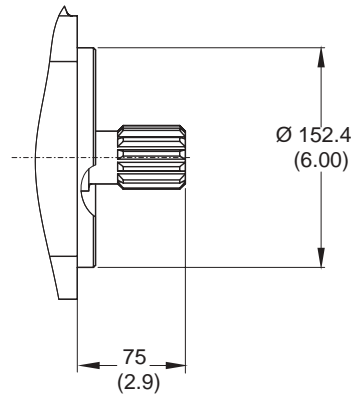

Shaft Option "E"
 (SAE "D")
 13 Tooth, 18/16 DP
 Flat Root, Side Fit
 Max Torque = 1218 Nm (15,080 In-Lbs)

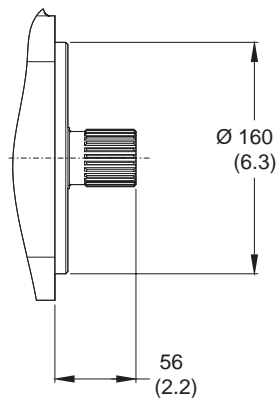

Shaft Option "L"
 W40mm x 1.5mm x 25mm x 8f
 DIN 5480
 Max Torque = 1400 Nm (12,391 In-Lbs)

Thru-Shaft Options

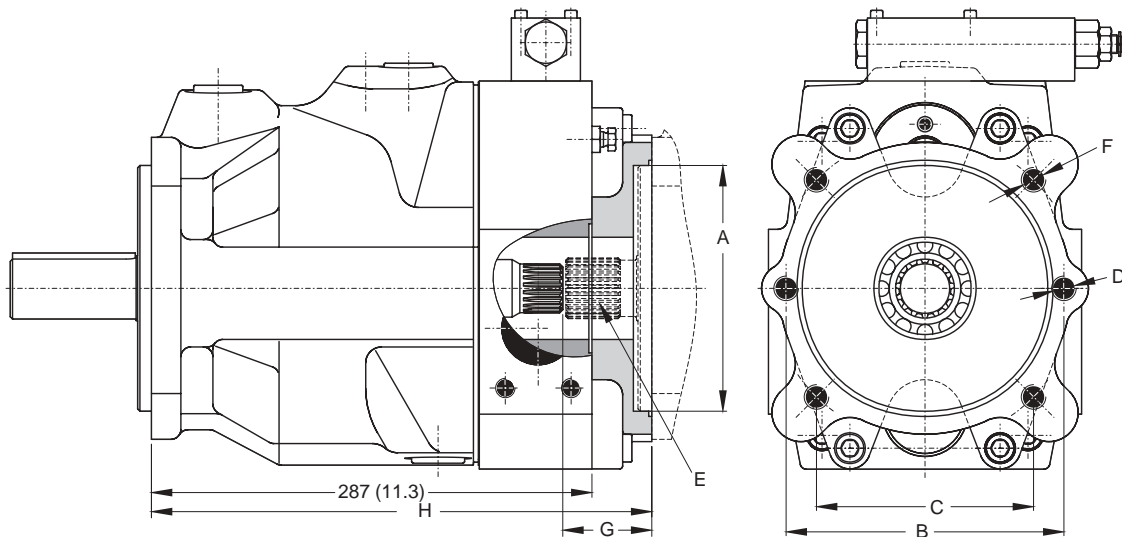

Thru-Shaft Load Limitations

The maximum allowable torque of the individual shaft must not be exceeded. For 2-pump combinations there is no problem because the PV series offers 100% thru torque capabilities. For 3-pump combinations or more the limit torque could be reached or exceeded. Therefore it is necessary to calculate the torque factor and compare the sum of each pumps torque factor to the table to make sure it does not exceed the torque limit factor.

Pump	Shaft	Torque Limit Factor
PV063-092	D	77280
	E	72450
	K	67620
	L	83720

Required: Sum of all calculated torque factors must be <torque limit factor.

Torque factor of any pump =
 Pressure (bar) x Displacement (cc/rev)

Code	A	B	C	D	E*	F	G	H
A7	Ø3.25"	4.188"	-	3/8-16	SAE "A" 9T 16/32 DP SPLINE	-	2.28"	12.83"
B3	Ø4.00"	-	3.536"	-	SAE "B" 13T 16/32 DP SPLINE	1/2-13	2.28"	12.83"
B7	Ø4.00"	5.750"	-	1/2-13	SAE "B" 13T 16/32 DP SPLINE	-	2.28"	12.83"
C3	Ø5.00"	-	4.500"	-	SAE "C" 14T 12/24 DP SPLINE	1/2-13	2.28"	12.83"
C7	Ø5.00"	7.125"	-	5/8-11	SAE "C" 14T 12/24 DP SPLINE	-	2.28"	12.83"
D3	Ø6.00"	-	6.364"	-	SAE "D" 13T 8/16 DP SPLINE	5/8-11	3.07"	13.62"
J3	Ø100mm	-	44mm	-	W25 x 1.5 x 15 x 8f SPLINE	M10	2.28"	12.83"
K3	Ø125mm	-	56mm	-	W32 x 1.5 x 20 x 8f SPLINE	M12	2.28"	12.83"
L3	Ø160mm	-	71mm	-	W40 x 1.5 x 25 x 8f SPLINE	M16	2.28"	12.83"
W3	Ø4.00"	-	3.530"	-	SAE "BB" 15T 16/32 DP SPLINE	1/2-13	2.28"	12.83"
W7	Ø4.00"	5.750"	-	1/2-13	SAE "BB" 15T 16/32 DP SPLINE	-	2.28"	12.83"

*Coupling included with pump if ordered from Greeneville, TN

Variable Volume Piston Pumps Series PV 063/080/092

Ordering Information

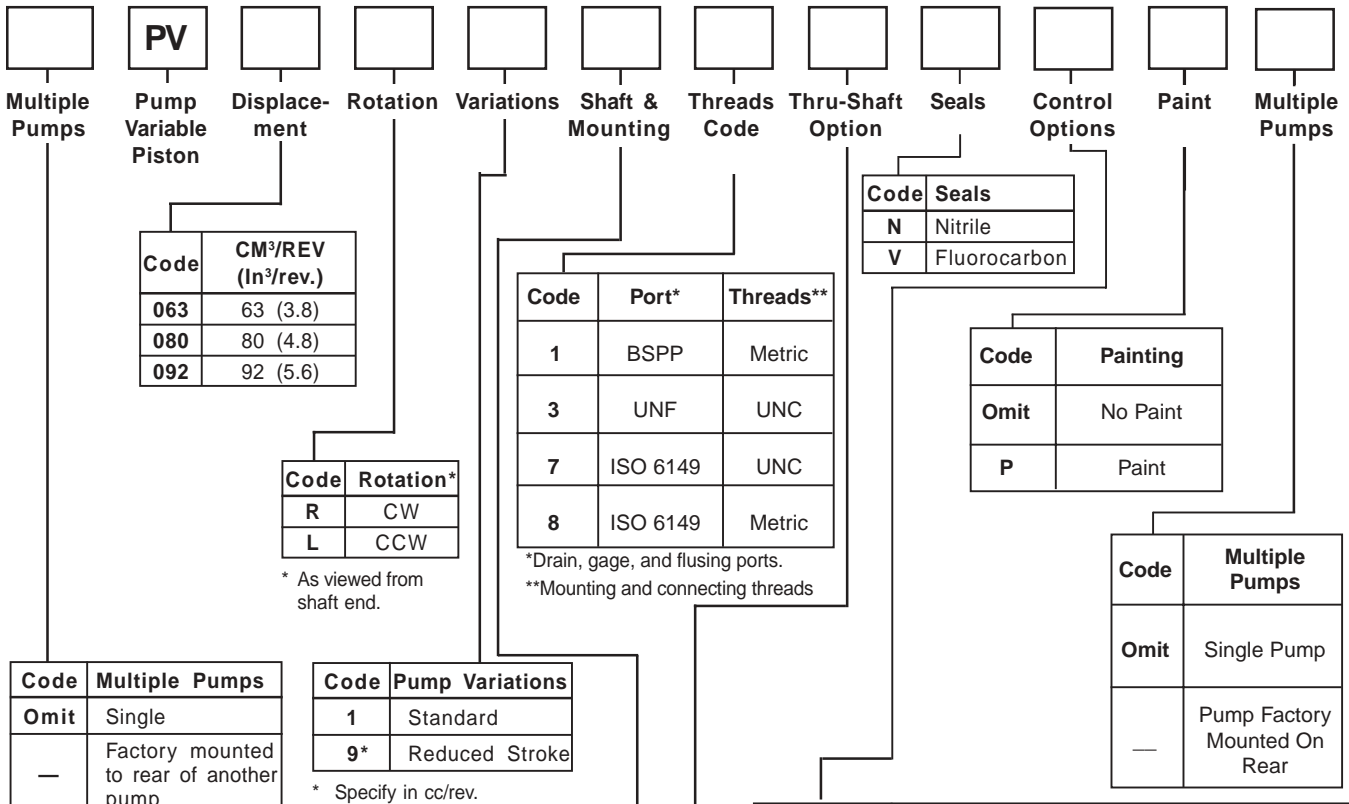

Code	CM³/REV (In³/rev.)
063	63 (3.8)
080	80 (4.8)
092	92 (5.6)

Code	Rotation*
R	CW
L	CCW

* As viewed from shaft end.

Code	Port*	Threads**
1	BSPP	Metric
3	UNF	UNC
7	ISO 6149	UNC
8	ISO 6149	Metric

*Drain, gage, and flusing ports.

**Mounting and connecting threads

Code	Seals
N	Nitrile
V	Fluorocarbon

Code	Painting
Omit	No Paint
P	Paint

Code	Multiple Pumps
Omit	Single Pump
—	Pump Factory Mounted On Rear

Code	Multiple Pumps
Omit	Single
—	Factory mounted to rear of another pump

Code	Pump Variations
1	Standard
9*	Reduced Stroke

* Specify in cc/rev.

Code	Shaft	Pilot
D	1-3/4" Keyed (SAE D)	4 Bolt SAE "D"
E	17T Spline (SAE CC)	4 Bolt SAE "D"
K	40mm Keyed	4 Bolt 160mm
L	W40 x 1.5 x 25 x 8f Spline DIN 5480	4 Bolt 160mm

Code	Thru-Shaft Option
T1	Thru-Shaft Capable/ Single Pump w/Cover
A7	2 Bolt SAE "A" Pilot Ø3.250/SAE "A" 9T 16/32 DP Spline
B3	4 Bolt SAE "B" Pilot Ø4.00/SAE "B" 13T 16/32 DP Spline
B7	2 Bolt SAE "B" Pilot Ø4.00/SAE "B" 13T 16/32 DP Spline
C3	4 Bolt SAE "C" Pilot Ø5.00/SAE "C" 14T 12/24 DP Spline
C7	2 Bolt SAE "C" Pilot Ø5.00/SAE "C" 14T 12/24 DP Spline
D3	4 Bolt SAE "D" Pilot Ø6.00/SAE "D" 13T 8/16 DP Spline
J3*	4 Bolt 100mm Pilot /W25x1.5x15x8f Spline DIN 5480
K3*	4 Bolt 125mm Pilot /W32x1.5x20x8f Spline DIN 5480
L3*	4 Bolt 160mm Pilot /W40x1.5x25x8f Spline DIN 5480
W3	4 Bolt SAE "B" Pilot 4.00/SAE "BB" 15T 16/32 DP Spline
W7	2 Bolt SAE "B" Pilot 4.00/SAE "BB" 15T 16/32 DP Spline

*Must be used with port/thread option 1

Code	Control Options
F ● ●	Standard Pressure Compensator
↕	Adjustment Type
S	Screw With Nut
↕	Pressure Range
W	70-350 bar (1015-5075 PSI)
H	40-210 bar (580-3050 PSI)
D	10-140 bar (150-2050 PSI)
F ● ●	Remote/Load Sense Compensator
↕	Control Port
1	NG6/Cetop3 (D1VW) Pattern *
Z	NG6 with Pressure Valve Mnt'd**
↕	Compensator Control Type
R	Remote Pressure
F	Load Sensing
● L ●	Horsepower Compensator Control
↕	Control Port
A	NG6 /Cetop3 (DIVW) Pattern*
C	NG6 with PVAC1PCS*S** Valve Mounted
Z	NG6 with Pressure Valve Mounted**
↕	Input Horsepower at 1800 RPM
G	20.0 (700 in-lb Torque)
H	25.0 (875 in-lb Torque)
K	30.0 (1050 in-lb Torque)
M	35.0 (1225 in-lb Torque)
S	50.0 (1750 in-lb Torque)
T	60.0 (2100 in-lb Torque)
U	75.0 (2625 in-lb Torque)

* Maximum pressure adjustment not included, but recommended. (See PVAC Section)

** Valve to be mounted at factory must be ordered as a separate line item. Consult factory. See PVAC section for pressure valve options.



Performance Information

Series PV 140/180 Pressure Compensated, Variable Volume, Piston Pumps

Features

- High Strength Cast-Iron Housing for reliable and quiet operation
- Modular Controls for field convertibility
- Large Control Piston for smooth/fast response
- Multiple Pressure Control with valves mounted directly on pump
- Pre-Compression chamber to minimize over-all system noise

Controls

- Pressure Compensation
- Remote Pressure Compensation
- Load Sensing
- Adjustable Maximum Volume Stop
- Electrohydraulic Pressure
- Dual and Tri-Pressure Control
- Low Pressure Standby
- Horsepower Limiting

Schematic Symbol

(Basic Pump)

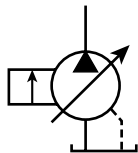

Installation Data

See Installation Information on page A156 of this catalog for specific recommendations pertaining to system cleanliness, fluids, start-up, inlet conditions, shaft alignment, drain line restrictions and other important factors relative to the proper installation and use of these products.



Specifications

Pressure Ratings: 5000 PSI (350 bar) Continuous
 6000 PSI (420 bar) Peak

Speed Ratings: 750 to 2200 RPM

Inlet Condition: 725 PSI (50 bar) Maximum
 3 In-Hg Vacuum at 1500 RPM
 0 In-Hg Vacuum at 1800 RPM

Case Drain Conditions: 7 PSI (.5 bar) Maximum

Operating Temp. Range: -40°F to 160°F
 (-40°C to 70°C)

Housing Material: Cast Iron

Filtration: Maintain SAE Class 4 (ISO 16/13)

Mounting: SAE "D" 4-Bolt Flange

Quick Reference Data Chart

Pump Model	Displacement cc/rev (in ³ /rev)	Pump Delivery @ 7 bar (100 PSI) in LPM (GPM)		*Approx. Noise Levels dB(A) @ Full Flow and 1500 RPM			Input Power At 1800 RPM, Max. Displacement & 343 bar (5000 PSI)	Max Operating Speed (RPM)
				70 bar (1000 PSI)	207 bar (3000 PSI)	343 bar (5000 PSI)		
		1200 RPM	1800 RPM					
PV140	140 (8.59)	168 (44.4)	234 (61.8)	70	74	76	149.4 kw (200.4 hp)	2400
PV180	180 (10.98)	216 (57.1)	324 (85.6)	71	75	77	210.3 kw (282.0 hp)	2200

* The noise level values are based on anechoic room measurements at a distance of 1 meter in accordance with DIN 45645.

Performance Curves

Fluid: Standard Hydraulic Oil 100 SSU @ 120°F (49°C)

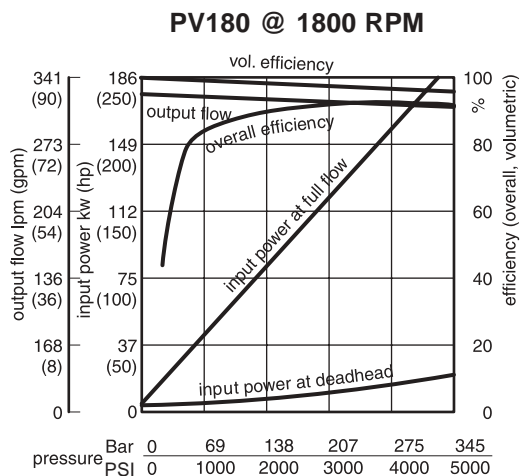
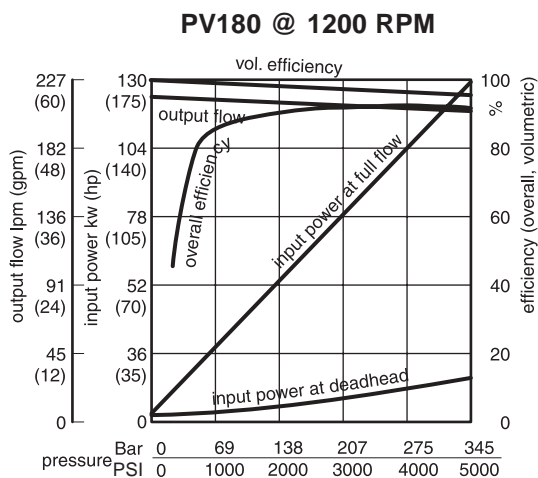
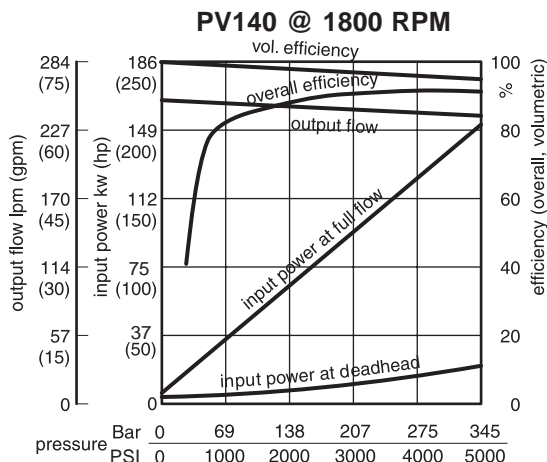
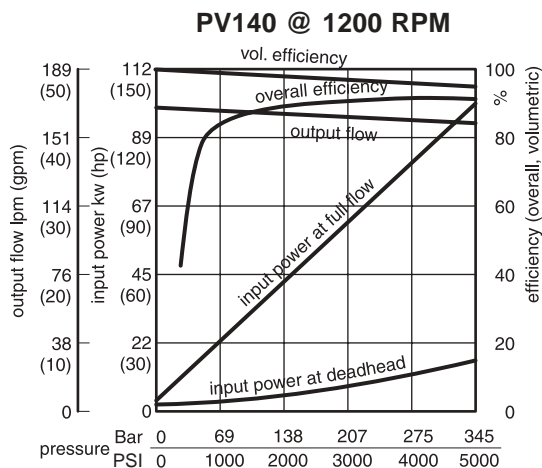

NOTE: The efficiencies and data in the graphs are good only for pumps running at speeds shown and stroked to maximum. To calculate approximate horsepower for the other conditions, use the following formula:

$$HP = \left[\frac{Q \times (PSI)}{1714} \right] + (CHp)$$

Actual GPM is directly proportional to drive speed and maximum volume setting. Flow loss, however, is a function of pressure only.

WHERE:

Q = Actual Output Flow in GPM

PSI = Pressure At Pump Outlet

CHp = Input Horsepower @ Full compensation @ 1800 RPM (from graph read at operating pressure)

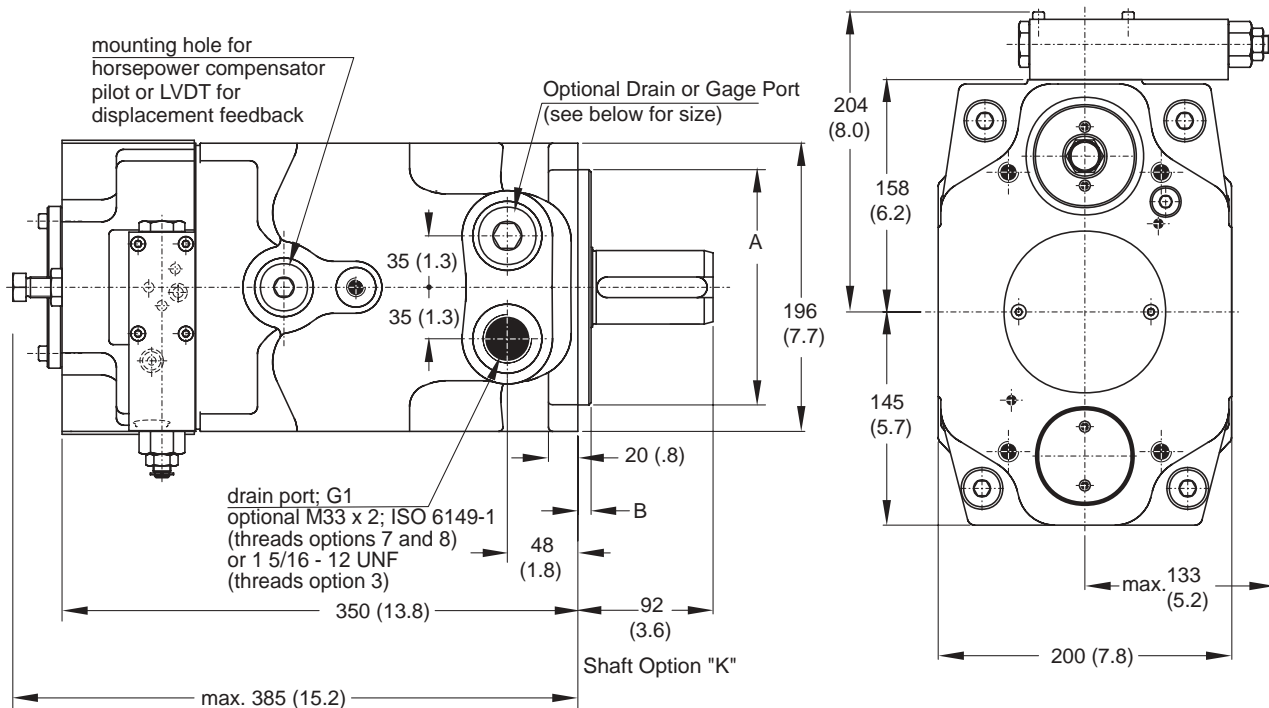

View X
 Shown with standard pressure compensator

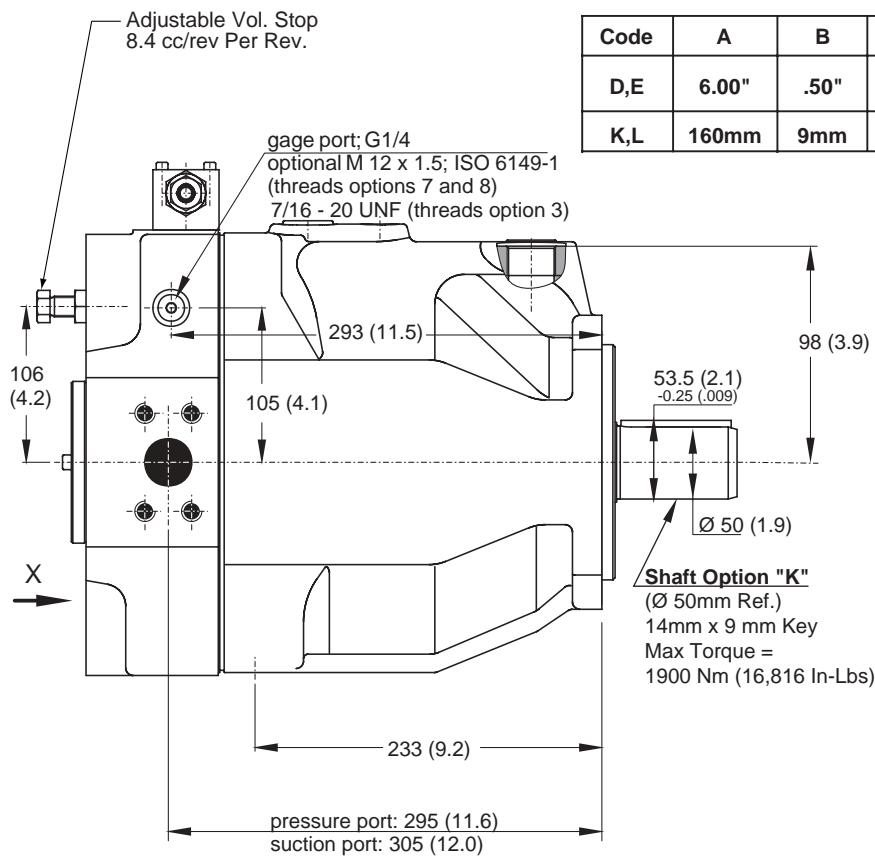

Code	A	B	ØC	ØD
D,E	6.00"	.50"	9.00"	.81"
K,L	160mm	9mm	200mm	18mm

Shaft Option "K"
 (Ø 50mm Ref.)
 14mm x 9 mm Key
 Max Torque =
 1900 Nm (16,816 In-Lbs)

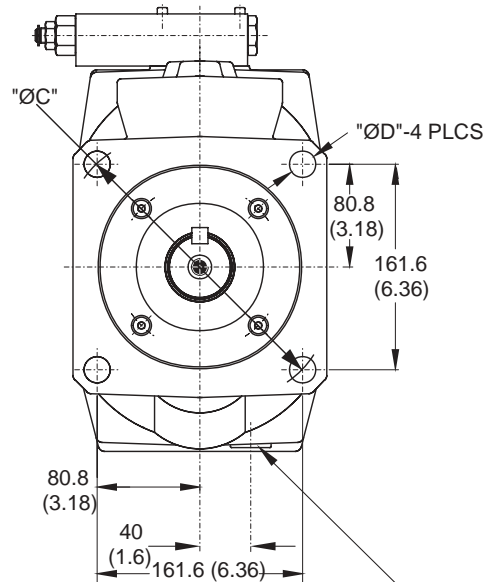

flushing port: G3/4
 optional M 27 x 2; ISO 6149-1
 (threads options 7 and 8) or
 1 1/16-12 UNF (threads option 3)

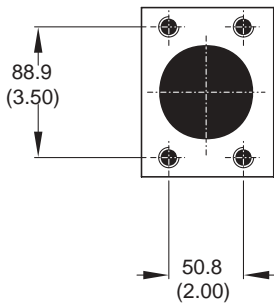

Inlet:
Option 3 & 7
 2-1/2" 4 Bolt Flange
 1/2-13 UNC-2B Threads
Option 1 & 8
 63mm 4 Bolt Flange
 M16 Threads
 Standard Pressure Series
 (Code 61)

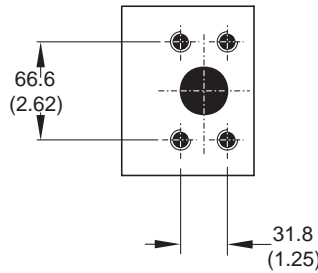

Outlet:
Option 3 & 7
 1-1/4" 4 Bolt Flange
 1/2-13 UNC-2B Threads
Option 1 & 8
 32mm 4 Bolt Flange
 M12 Threads
 High Pressure Series (Code 62)

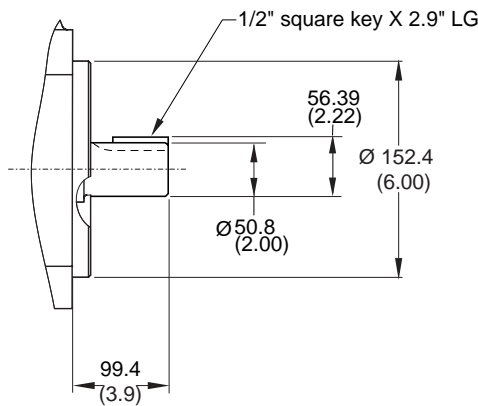

Shaft Option "D"
 (SAE "F")
 Max Torque= 2000 Nm (17,701 In-Lbs)

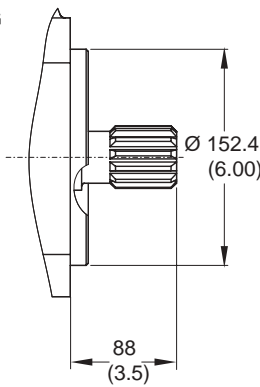

Shaft Option "E"
 (SAE "F")
 15 Teeth, 8/16 Pitch
 30° Involute Spline
 Max Torque = 2680 Nm (23,720 In-Lbs)

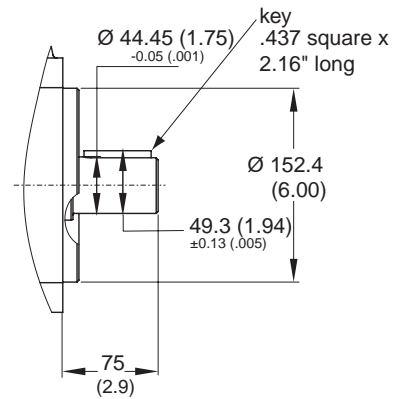

Shaft Option "F"
 (SAE "D")
 Max Torque= 1320 Nm (11,683 In-Lbs)

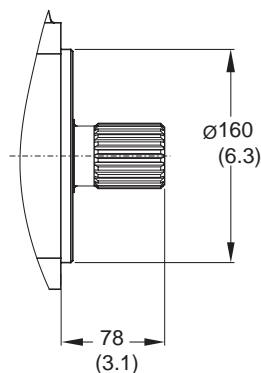

Shaft Option "L"
 W50mm x 2mm x 24mm x 9g
 DIN 5480
 Max Torque = 2650 Nm (23,454 In-Lbs)

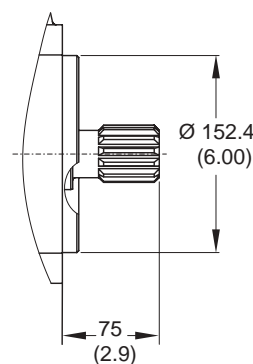

Shaft Option "G"
 (SAE "D")
 13 Teeth 8/16 Pitch
 30° Involute Spline
 Max Torque = 1640 Nm (14,515 In-Lbs)

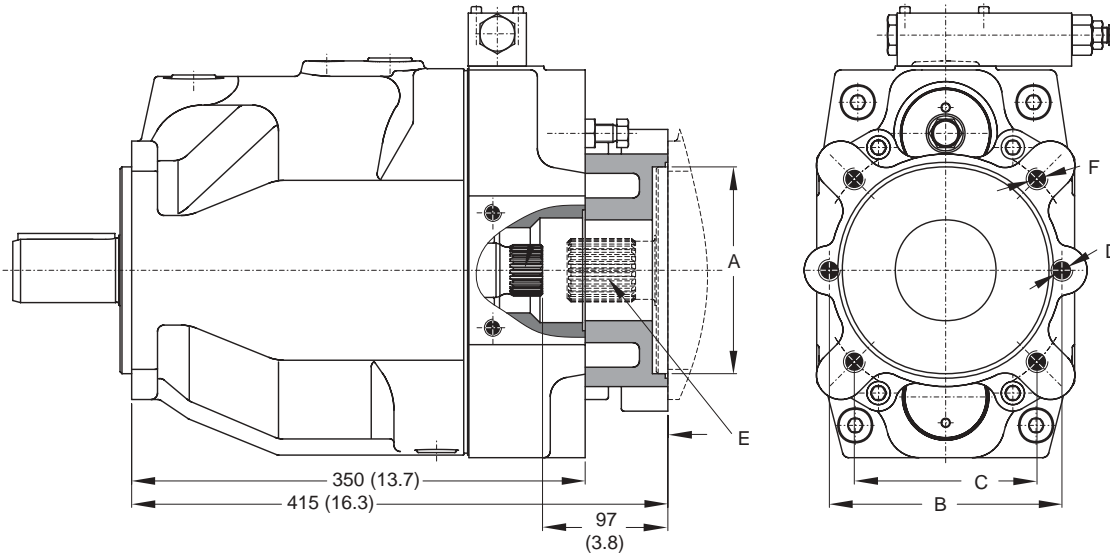

Thru-Shaft Options

Thru-Shaft Load Limitations

The maximum allowable torque of the individual shaft must not be exceeded. For 2-pump combinations there is no problem because the PV series offers 100% thru torque capabilities. For 3-pump combinations or more the limit torque could be reached or exceeded. Therefore it is necessary to calculate the torque factor and compare the sum of each pumps torque factor to the table to make sure it does not exceed the torque limit factor.

Required: Sum of all calculated torque factors must be <torque limit factor.

Torque factor of any pump =
 Pressure (bar) x Displacement (cc/rev)

Code	A	B	C	D	E*	F
A7	Ø3.25"	4.188"	-	3/8-16	SAE "A" 9T 16/32 DPSPLINE	-
B3	Ø4.00"	-	3.536"	-	SAE "B" 13T 16/32 DP SPLINE	1/2-13
B7	Ø4.00"	5.750"	-	1/2-13	SAE "B" 13T 16/32 DP SPLINE	-
C3	Ø5.00"	-	4.508"	-	SAE "C" 14T 12/24 DP SPLINE	1/2-13
D3	Ø6.00"	-	6.364"	-	SAE "CC" 13T 8/16 DP SPLINE	5/8-11
D7	Ø6.00"	9.000"	-	5/8-11	SAE "D" 13T 8/16 DP SPLINE	-
J3	Ø100mm	-	44mm	-	W25 x 1.5 x 15 x 8f SPLINE	M10
K3	Ø125mm	-	56mm	-	W32 x 1.5 x 20 x 8f SPLINE	M12
L2	Ø160mm	-	71mm	-	W50 x 2 x 24 x 9g SPLINE	M12
L3	Ø160mm	-	71mm	-	W40 x 1.5 x 25 x 8f SPLINE	M17
W3	Ø4.00"	-	3.536"	-	SAE "BB" 15T 16/32 DP SPLINE	1/2-13
W7	Ø4.00"	5.750"	-	1/2-13	SAE "BB" 15T 16/32 DP SPLINE	-
Z3	Ø6.00"	-	6.364"	-	SAE "F" 15T 8/16 DP SPLINE	5/8-11

Pump	Shaft	Torque Limit Factor
PV140-180	D	118400
	E	158760
	F	78750
	G	97650
	K	113400
	L	157500

*Coupling included when ordered from Greenville, TN

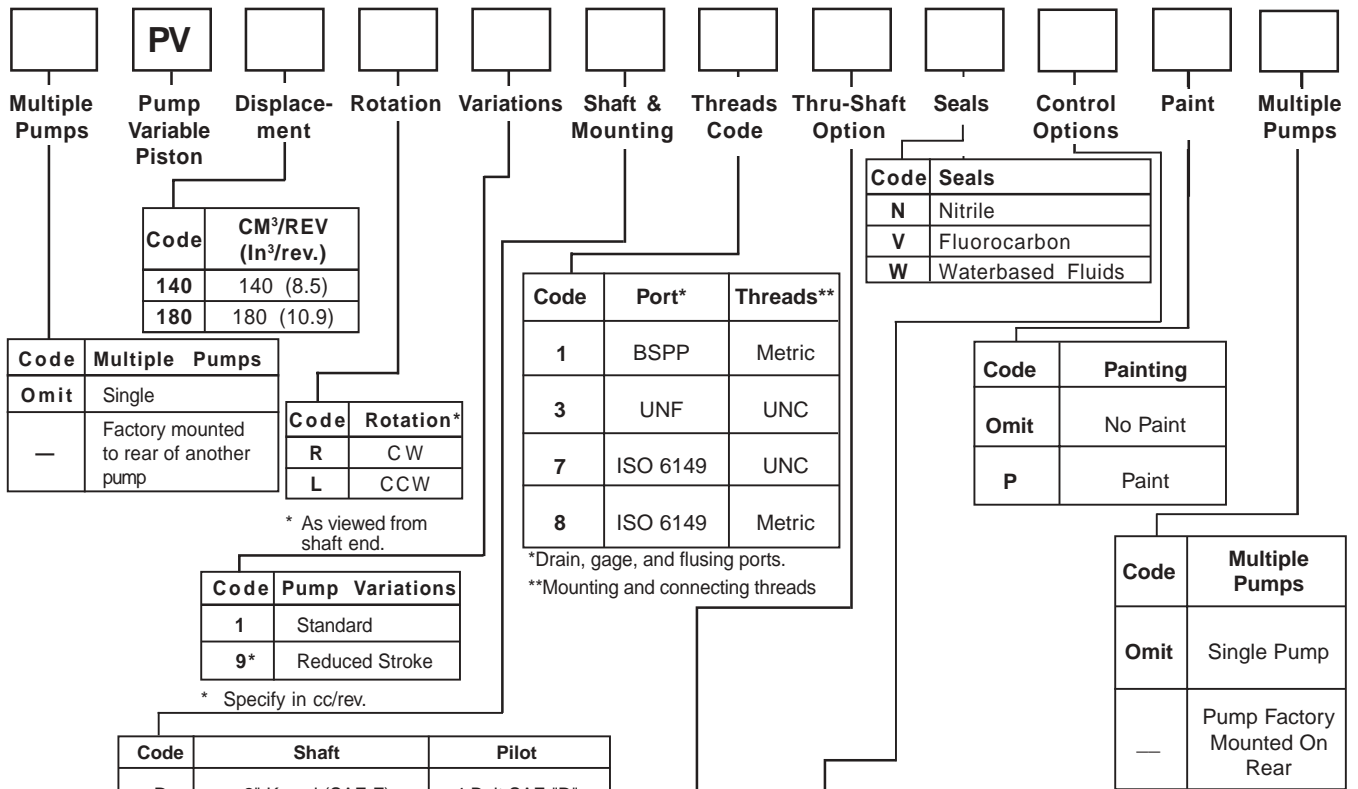

Code	Multiple Pumps
Omit	Single
—	Factory mounted to rear of another pump

Code	CM ³ /REV (In ³ /rev.)
140	140 (8.5)
180	180 (10.9)

Code	Rotation*
R	CW
L	CCW

* As viewed from shaft end.

Code	Pump Variations
1	Standard
9*	Reduced Stroke

* Specify in cc/rev.

Code	Port*	Threads**
1	BSPP	Metric
3	UNF	UNC
7	ISO 6149	UNC
8	ISO 6149	Metric

*Drain, gage, and flusing ports.

**Mounting and connecting threads

Code	Seals
N	Nitrile
V	Fluorocarbon
W	Waterbased Fluids

Code	Painting
Omit	No Paint
P	Paint

Code	Multiple Pumps
Omit	Single Pump
—	Pump Factory Mounted On Rear

Code	Shaft	Pilot
D	2" Keyed (SAE F)	4 Bolt SAE "D"
E	15T Spline (SAE F)	4 Bolt SAE "D"
F	1-3/4" Keyed (SAE D)	4 Bolt SAE "D"
G	13T Spline (SAE D)	4 Bolt SAE "D"
K	50mm Keyed	4 Bolt 160mm
L	W50 x 2 x 24 x 9g Spline DIN 5480	4 Bolt 160mm

Code	Thru-Shaft Option
T1	Thru-Shaft Capable, Single Pump w/Cover
A7	2 Bolt SAE "A" Pilot Ø3.25/SAE "A" 9T 16/32 DP Spline
B3	4 Bolt SAE "B" Pilot Ø4.00/SAE "B" 13T 16/32 DP Spline
B7	2 Bolt SAE "B" Pilot Ø4.00/SAE "B" 13T 16/32 DP Spline
C3	4 Bolt SAE "C" Pilot Ø5.00/SAE "C" 14T 12/24 DP Spline
C7	2 Bolt SAE "C" Pilot Ø5.00/SAE "C" 14T 12/24 DP Spline
D3	4 Bolt SAE "D" Pilot Ø6.00/SAE "D" 13T 8/16 DP Spline
D7	2 Bolt SAE "D" Pilot Ø6.00/SAE "D" 13T 8/16 DP Spline
J3*	4 Bolt 100mm Pilot /W25x1.5x15x8f Spline DIN 5480
K3*	4 Bolt 125mm Pilot /W32x1.5x20x8f Spline DIN 5480
L2*	4 Bolt 160mm Pilot /W50x2x24x9g Spline DIN 5480
L3*	4 Bolt 160mm Pilot /W40x1.5x25x8f Spline DIN 5480
W3	4 Bolt SAE "B" Pilot 4.00/SAE "BB" 15T 16/32 DP Spline
W7	2 Bolt SAE "B" Pilot 4.00/SAE "BB" 15T 16/32 DP Spline
Z3	4 Bolt SAE "D" Pilot 6.00/SAE "F" 15T 8/16 DP Spline
Z7	2 Bolt SAE "D" Pilot 6.00/SAE "F" 15T 8/16 DP Spline

*Must be used with port/thread option 1

Code	Control Options
F	Standard Pressure Compensator
	Adjustment Type
S	Screw With Nut
	Pressure Range
W	70-350 bar (1015-5075 PSI)
H	40-210 bar (580-3050 PSI)
D	10-140 bar (150-2050 PSI)
F	Remote Pressure Compensator
	Control Port
1	NG6/Cetop3 Pattern *
Z	NG6 with Pressure Valve Mounted**
	Control Type
R	Remote Compensator
F	Load Sensing Compensator
L	Horsepower Compensator
	Control Port
A	NG6/Cetop (DIVW) Pattern*
C	NG6 with PVAC1PCS*S** Valve Mounted
Z	NG6 with Pressure Valve Mounted**
	HP setting at 1800 RPM
K	30.0 (1050 in-lb Torque)
M	35.0 (1225 in-lb Torque)
S	50.0 (1750 in-lb Torque)
T	60.0 (2100 in-lb Torque)
U	75.0 (2625 in-lb Torque)
W	90.0 (3150 in-lb Torque)
Y	120.0 (4200 in-lb Torque)
Z	150.0 (5250 in-lb Torque)

* Maximum pressure adjustment not included, but recommended. (See PVAC Section)

** Valve to be mounted at factory must be ordered as a separate line item. Consult factory. See PVAC section for pressure valve options.

Performance Information

Series PV270 Pressure Compensated, Variable Volume, Piston Pumps

Features

- High Strength Cast-Iron Housing for reliable and quiet operation
- Modular Controls for field convertibility
- Large Control Piston for smooth/fast response
- Multiple Pressure Control with valves mounted directly on pump
- Pre-Compression chamber to minimize over-all system noise.

Controls

- Pressure Compensation
- Remote Pressure Compensation
- Load Sensing
- Adjustable Maximum Volume Control
- Electrohydraulic Pressure Control
- Dual and Tri-Pressure
- Low Pressure Standby
- Horsepower Limiting



Specifications

Pressure Ratings: 5000 PSI (350 bar) Continuous
 6000 PSI (420 bar) Peak

Speed Ratings: 750 to 1800 RPM

Inlet Condition: 725 PSI (50 bar) Maximum
 3 In-Hg Vacuum at 1500 RPM
 0 In-Hg Vacuum at 1800 RPM

Case Drain Conditions: 7 PSI (.5 bar) Maximum

Operating Temp. Range: -40°F to 160°F
 (-40°C to 70°C)

Housing Material: Cast Iron

Filtration: Maintain SAE Class 4 (ISO 16/13)

Mounting: SAE "E" 4-Bolt Flange

Schematic Symbol
 (Basic Pump)

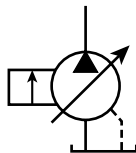

Installation Data

See Installation Information on page A156 of this catalog for specific recommendations pertaining to system cleanliness, fluids, start-up, inlet conditions, shaft alignment, drain line restrictions and other important factors relative to the proper installation and use of these products.

Quick Reference Data Chart

Pump Model	Displacement cc/rev (in ³ /rev)	Pump Delivery @ 7 bar (100 PSI) in LPM (GPM)		*Approx. Noise Levels dB(A) @ Full Flow and 1500 RPM			Input Power At 1800 RPM, Max. Displacement & 343 bar (5000 PSI)	Max Operating Speed (RPM)
		1200 RPM	1800 RPM	70 bar (1000 PSI)	207 bar (3000 PSI)	343 bar (5000 PSI)		
PV270	270 (16.5)	324 (85.6)	486 (128.4)	77	79	81	298 kw (400 hp)	1800

* The noise level values are based on anechoic room measurements at a distance of 1 meter in accordance with DIN 45645.

Performance Curves



Fluid: Standard Hydraulic Oil 100 SSU @ 120°F (49°C)

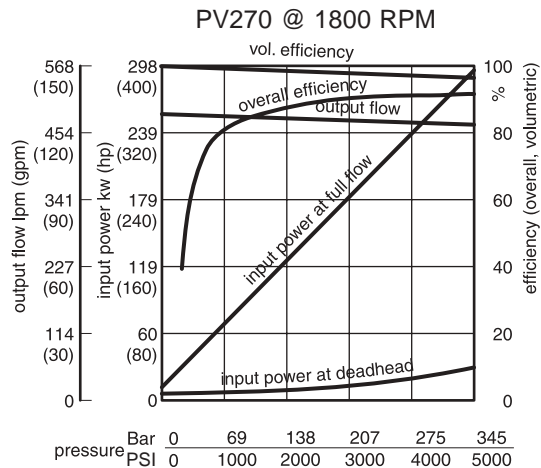
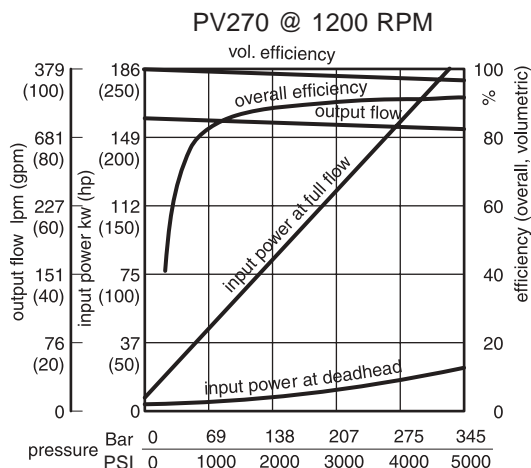

NOTE: The efficiencies and data in the graphs are good only for pumps running at speeds shown and stroked to maximum. To calculate approximate horsepower for the other conditions, use the following formula:

$$HP = \left[\frac{Q \times (PSI)}{1714} \right] + (CHp)$$

Actual GPM is directly proportional to drive speed and maximum volume setting. Flow loss, however, is a function of pressure only.

WHERE:

Q = Actual Output Flow in GPM

PSI = Pressure At Pump Outlet

CHp = Input Horsepower @ Full compensation @ 1800 RPM (from graph read at operating pressure)

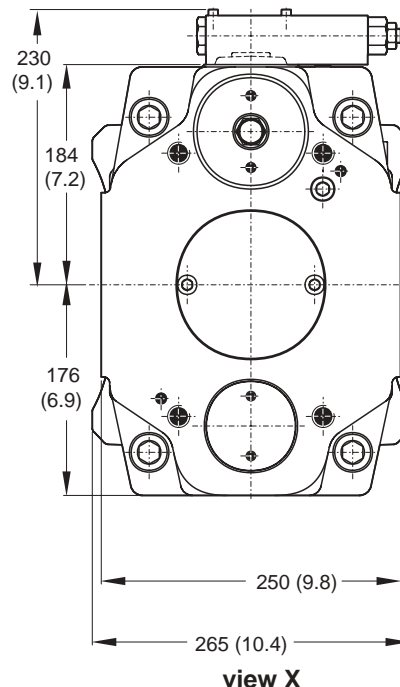
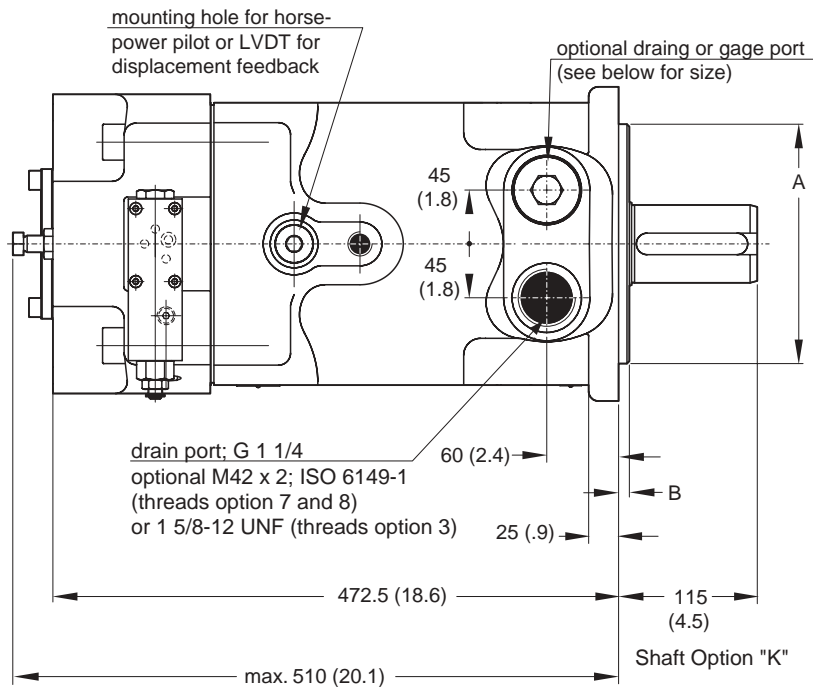

Shown with standard pressure compensator

Code	A	B	ØC	ØD
D,E	6.50"	.50"	12.50"	.81"
K,L	200mm	9mm	250mm	22mm

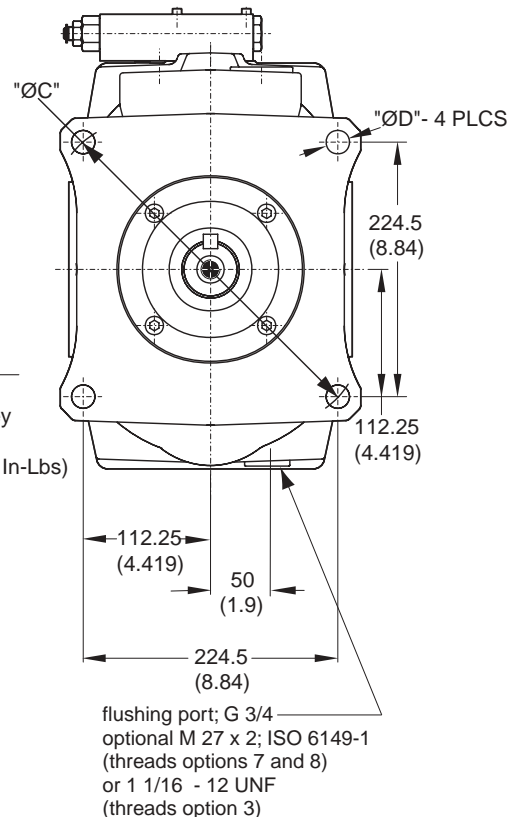
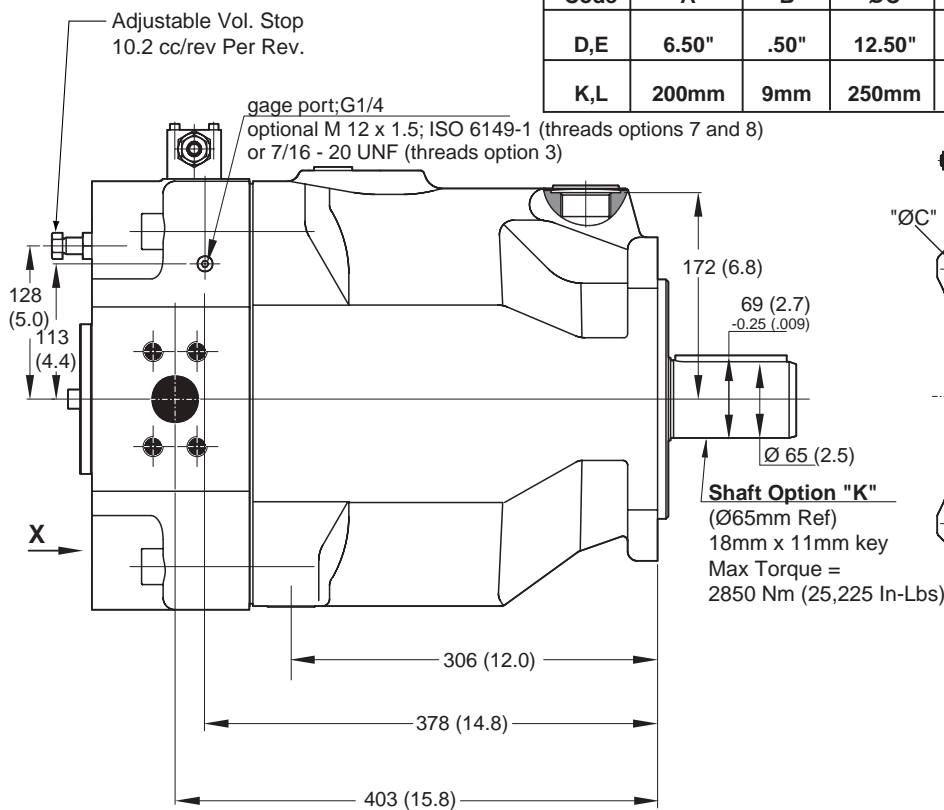

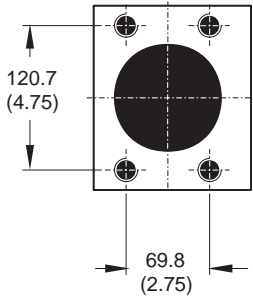

Inlet:
Option 3 & 7
 3-1/2" 4 Bolt Flange
 5.8-11 UNC-2B Threads
Option 1 & 8
 88mm 4 Bolt Flange
 M16 Threads
 Standard Pressure Series
 (Code 61)

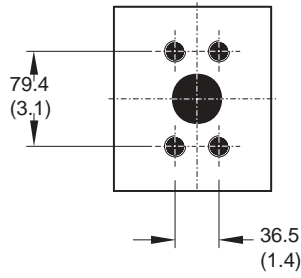

Outlet:
Option 3 & 7
 1-1/2" 4 Bolt Flange
 5/8-11 UNC-2B Threads
Option 1 & 8
 38mm 4 Bolt Flange
 M16 Threads
 High Pressure Series (Code 62)

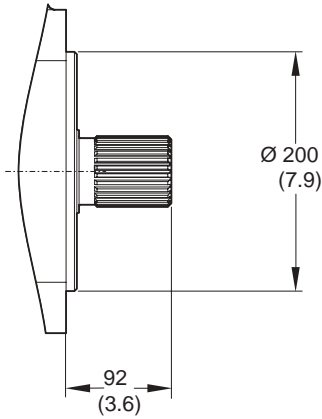

Shaft Option "L"
 W60mm x 2mm x 28mm x 9g
 DIN 5480
 Max Torque = 3980 Nm (35,226 In-Lbs)

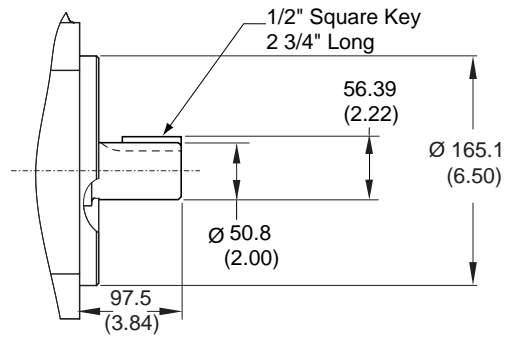

Shaft Option "D"
 Max Torque= 2000 Nm (17,701 In-Lbs)

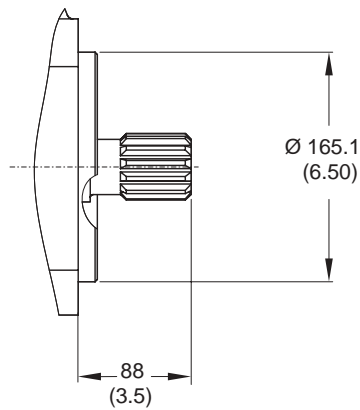

Shaft Option "E"
 (SAE FF)
 15 Teeth 8/16 Pitch
 30° Involute Spline
 Max Torque= 2680 Nm (23,720 In-Lbs)

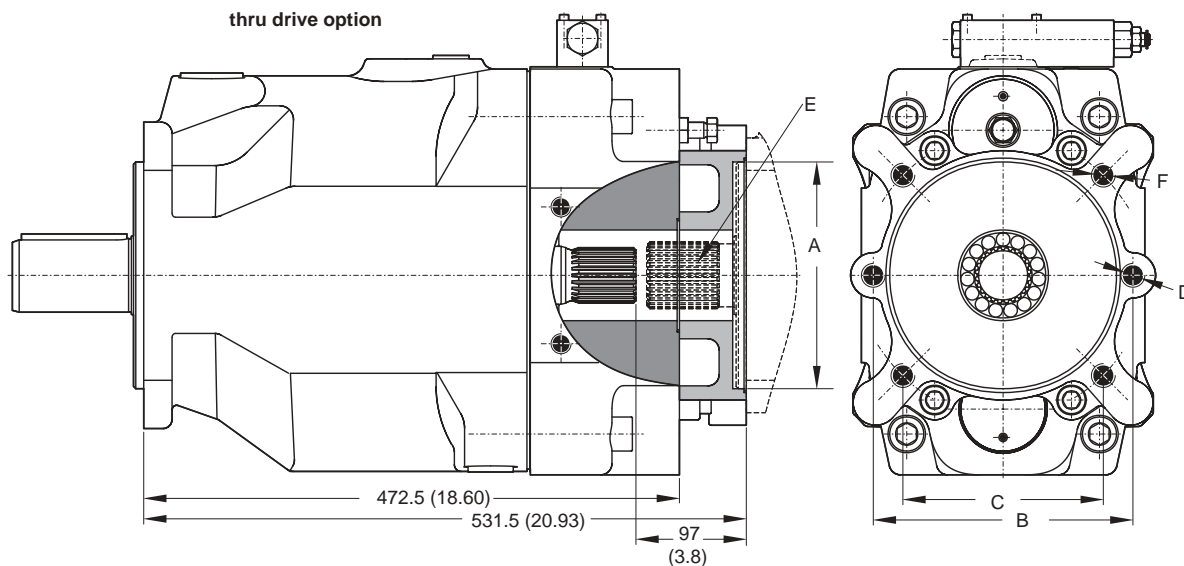

Thru-Shaft Load Limitations

The maximum allowable torque of the individual shaft must not be exceeded. For 2-pump combinations there is no problem because the PV series offers 100% thru torque capabilities. For 3-pump combinations or more the limit torque could be reached or exceeded. Therefore it is necessary to calculate the torque factor and compare the sum of each pumps torque factor to the table to make sure it does not exceed the torque limit factor.

Required: Sum of all calculated torque factors must be <torque limit factor.

Torque factor of any pump =
 Pressure x Displacement (cc/rev) bar

Code	A	B	C	D	E*	F
A7	Ø3.25"	4.188"	-	3/8-16	SAE "A" 9T 16/32 DPSPLINE	-
B3	Ø4.00"	-	3.536"	-	SAE "B" 13T 16/32 DP SPLINE	1/2-13
B7	Ø4.00"	5.750"	-	1/2-13	SAE "B" 13T 16/32 DP SPLINE	-
C3	Ø5.00"	-	4.508"	-	SAE "C" 14T 12/24 DP SPLINE	1/2-13
C7	Ø5.00"	7.125"	-	5/8-11	SAE "C" 14T 12/24 DP SPLINE	-
D3	Ø6.00"	-	6.364"	-	SAE "CC" 13T 8/16 DP SPLINE	5/8-11
D7	Ø6.00"	9.000"	-	5/8-11	SAE "D" 13T 8/16 DP SPLINE	-
E3	Ø6.50"	-	8.839"	-	SAE "F" 15T 8/16 DP SPLINE	3/4-10
J3	Ø100mm	-	44mm	-	W25 x 1.5 x 15 x 8f SPLINE	M10
K3	Ø125mm	-	56mm	-	W32 x 1.5 x 20 x 8f SPLINE	M12
L2	Ø160mm	-	71mm	-	W50 x 2 x 24 x 9g SPLINE	M12
L3	Ø160mm	-	71mm	-	W40 x 1.5 x 25 x 8f SPLINE	M17
M3	Ø200mm	-	88mm	-	W60 x 2 x 28 x 9g SPLINE	M20
W3	Ø4.00"	-	3.536"	-	SAE "BB" 15T 16/32 DP SPLINE	1/2-13
W7	Ø4.00"	5.750"	-	1/2-13	SAE "BB" 15T 16/32 DP SPLINE	-
Z3	Ø6.00"	-	6.364"	-	SAE "F" 15T 8/16 DP SPLINE	5/8-11
Z7	Ø6.00"	9.000"	-	5/8-11	SAE "F" 15T 8/16 DP SPLINE	-

Pump	Shaft	Torque Limit Factor
PV270	D	119,000
	E	159,700
	K	170,100
	L	236,250

*Coupling included when ordered from Greenville, TN

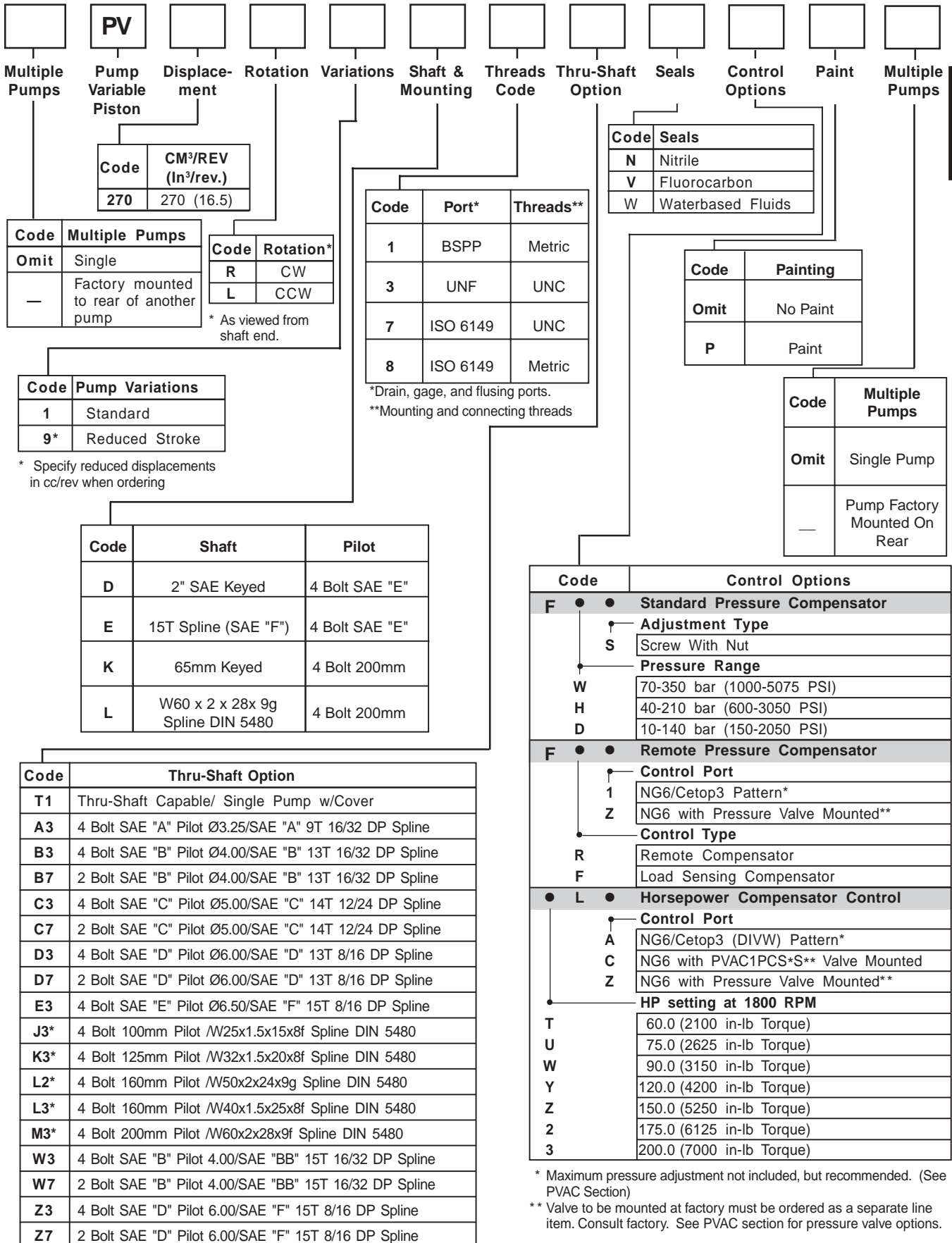

Code	Multiple Pumps
Omit	Single
—	Factory mounted to rear of another pump

Code	Rotation*
R	CW
L	CCW

* As viewed from shaft end.

Code	Pump Variations
1	Standard
9*	Reduced Stroke

* Specify reduced displacements in cc/rev when ordering

Code	Shaft	Pilot
D	2" SAE Keyed	4 Bolt SAE "E"
E	15T Spline (SAE "F")	4 Bolt SAE "E"
K	65mm Keyed	4 Bolt 200mm
L	W60 x 2 x 28x 9g Spline DIN 5480	4 Bolt 200mm

Code	Thru-Shaft Option
T1	Thru-Shaft Capable/ Single Pump w/Cover
A3	4 Bolt SAE "A" Pilot Ø3.25/SAE "A" 9T 16/32 DP Spline
B3	4 Bolt SAE "B" Pilot Ø4.00/SAE "B" 13T 16/32 DP Spline
B7	2 Bolt SAE "B" Pilot Ø4.00/SAE "B" 13T 16/32 DP Spline
C3	4 Bolt SAE "C" Pilot Ø5.00/SAE "C" 14T 12/24 DP Spline
C7	2 Bolt SAE "C" Pilot Ø5.00/SAE "C" 14T 12/24 DP Spline
D3	4 Bolt SAE "D" Pilot Ø6.00/SAE "D" 13T 8/16 DP Spline
D7	2 Bolt SAE "D" Pilot Ø6.00/SAE "D" 13T 8/16 DP Spline
E3	4 Bolt SAE "E" Pilot Ø6.50/SAE "F" 15T 8/16 DP Spline
J3*	4 Bolt 100mm Pilot W25x1.5x15x8f Spline DIN 5480
K3*	4 Bolt 125mm Pilot W32x1.5x20x8f Spline DIN 5480
L2*	4 Bolt 160mm Pilot W50x2x24x9g Spline DIN 5480
L3*	4 Bolt 160mm Pilot W40x1.5x25x8f Spline DIN 5480
M3*	4 Bolt 200mm Pilot W60x2x28x9f Spline DIN 5480
W3	4 Bolt SAE "B" Pilot 4.00/SAE "BB" 15T 16/32 DP Spline
W7	2 Bolt SAE "B" Pilot 4.00/SAE "BB" 15T 16/32 DP Spline
Z3	4 Bolt SAE "D" Pilot 6.00/SAE "F" 15T 8/16 DP Spline
Z7	2 Bolt SAE "D" Pilot 6.00/SAE "F" 15T 8/16 DP Spline

*Must be used with port/thread option 1

Code	Control Options
F ● ●	Standard Pressure Compensator
●	Adjustment Type
S	Screw With Nut
●	Pressure Range
W	70-350 bar (1000-5075 PSI)
H	40-210 bar (600-3050 PSI)
D	10-140 bar (150-2050 PSI)
F ● ●	Remote Pressure Compensator
●	Control Port
1	NG6/Cetop3 Pattern*
Z	NG6 with Pressure Valve Mounted**
●	Control Type
R	Remote Compensator
F	Load Sensing Compensator
● L ●	Horsepower Compensator Control
●	Control Port
A	NG6/Cetop3 (DIVW) Pattern*
C	NG6 with PVAC1PCS*S** Valve Mounted
Z	NG6 with Pressure Valve Mounted**
●	HP setting at 1800 RPM
T	60.0 (2100 in-lb Torque)
U	75.0 (2625 in-lb Torque)
W	90.0 (3150 in-lb Torque)
Y	120.0 (4200 in-lb Torque)
Z	150.0 (5250 in-lb Torque)
2	175.0 (6125 in-lb Torque)
3	200.0 (7000 in-lb Torque)

* Maximum pressure adjustment not included, but recommended. (See PVAC Section)

** Valve to be mounted at factory must be ordered as a separate line item. Consult factory. See PVAC section for pressure valve options.

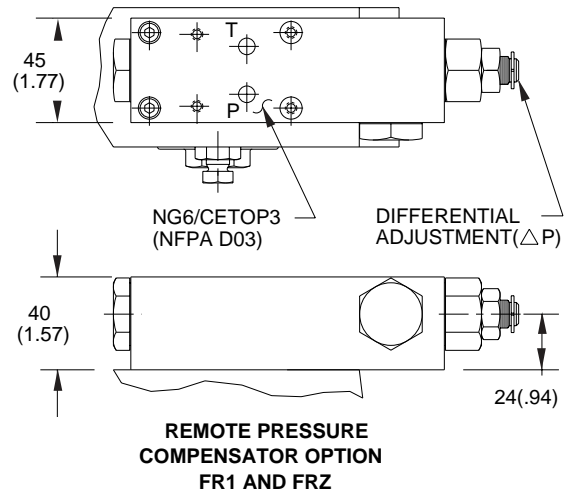
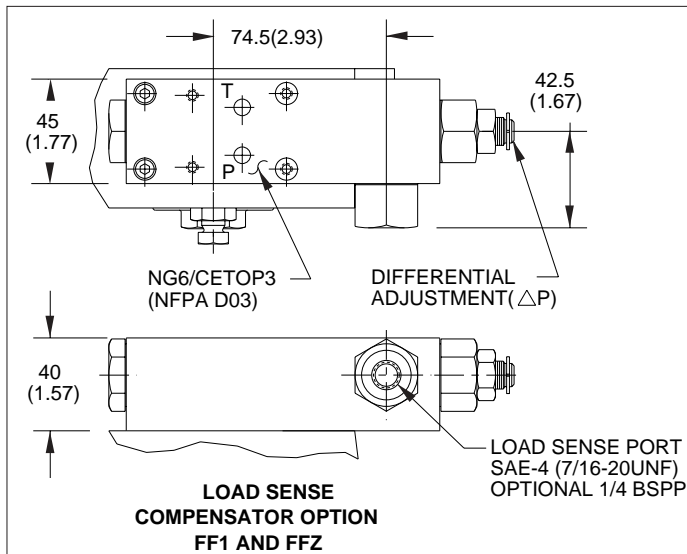
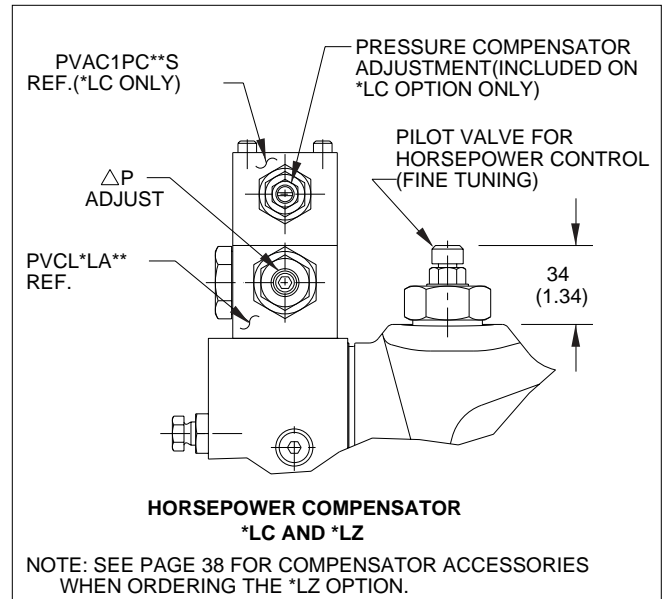
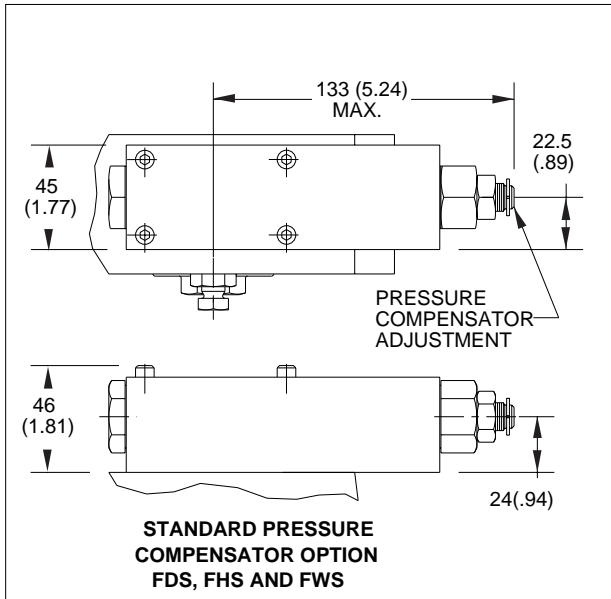

NOTE: SEE PAGE 38 FOR COMPENSATOR ACCESSORIES WHEN ORDERING THE FFZ OR FRZ OPTION.
CAUTION: FF1 & FR1 CONTROL OPTIONS DO NOT HAVE A PUMP MAX. PRESSURE LIMITER (COMPENSATOR) INSTALLED. DO NOT ATTEMPT TO OPERATE PUMP WITHOUT INSTALLING A COMPENSATOR CONTROL.

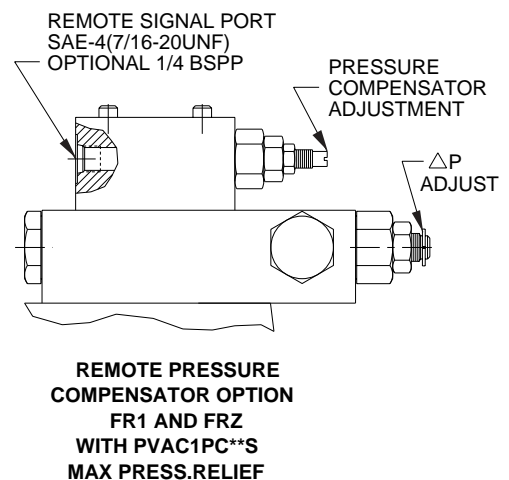
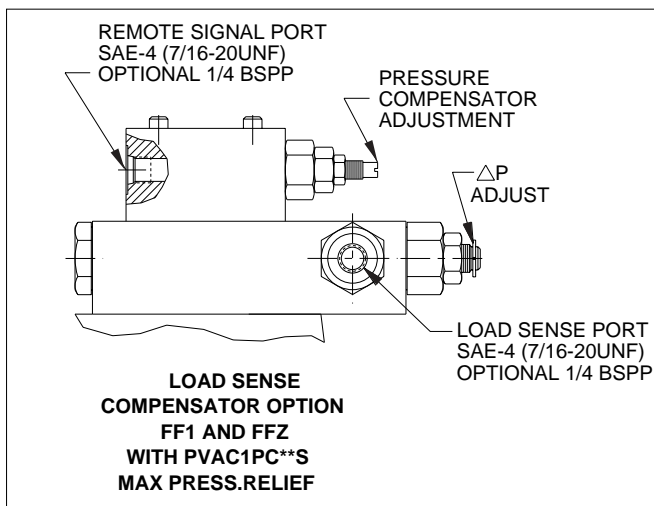

Variable Volume Piston Pumps General PV Series

Control Options

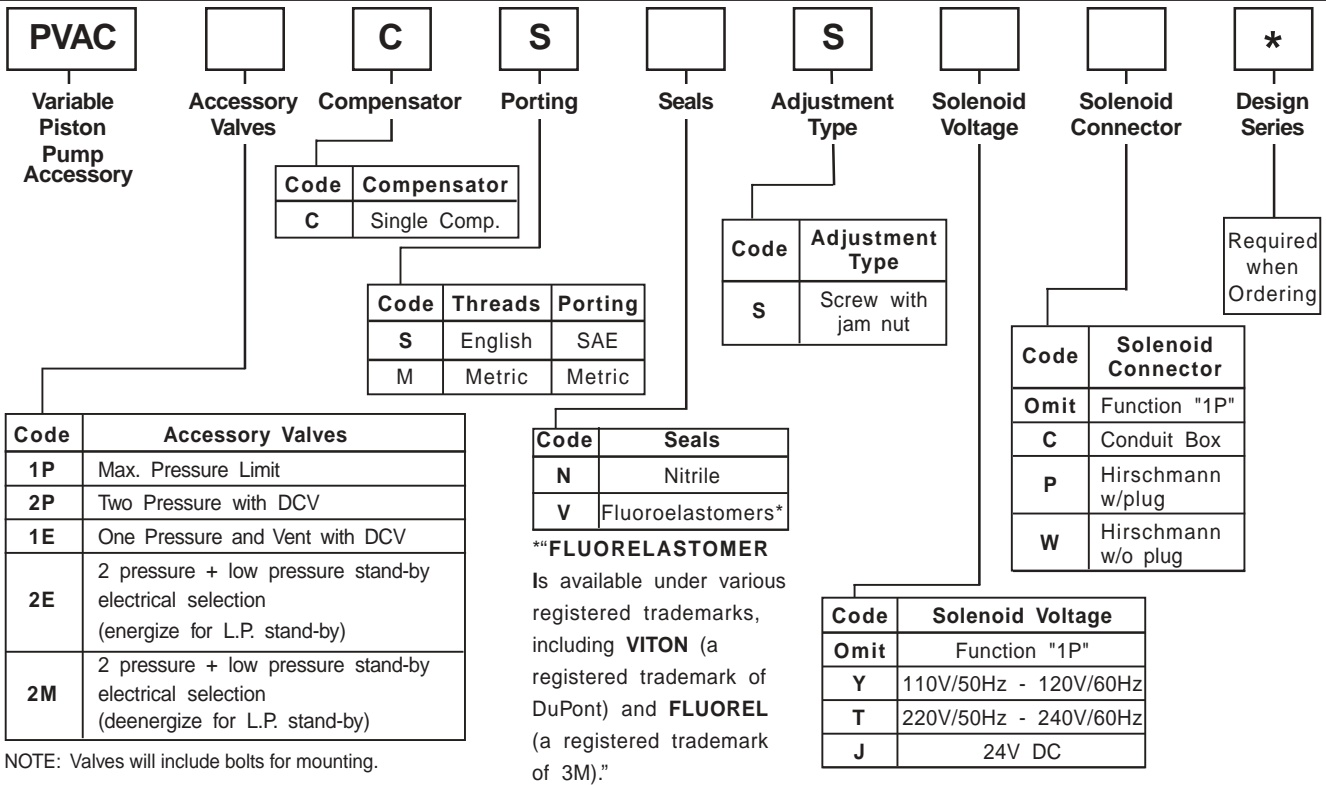

NOTE: Valves will include bolts for mounting.

Dimensions

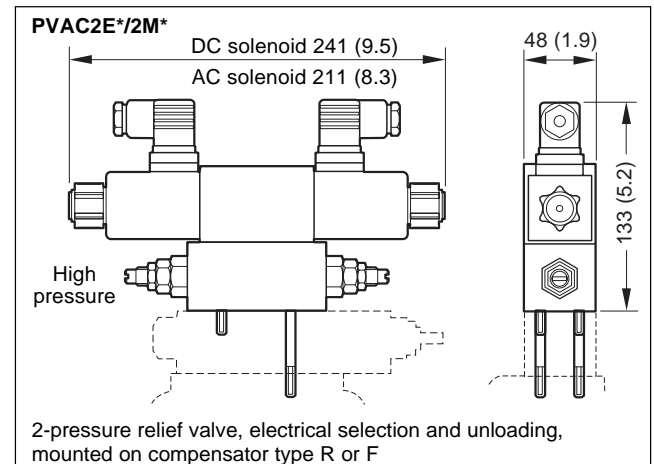
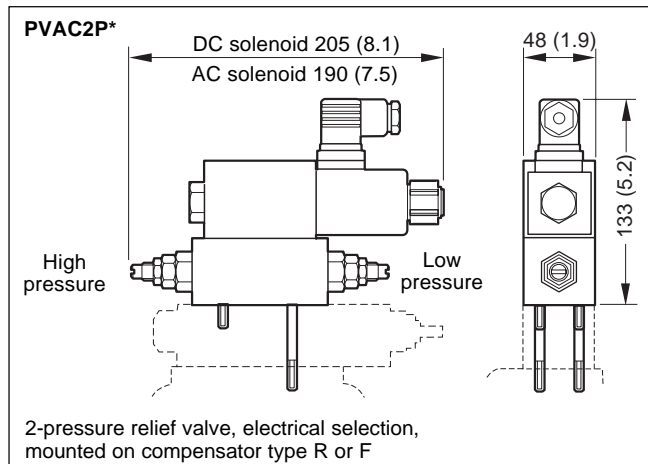
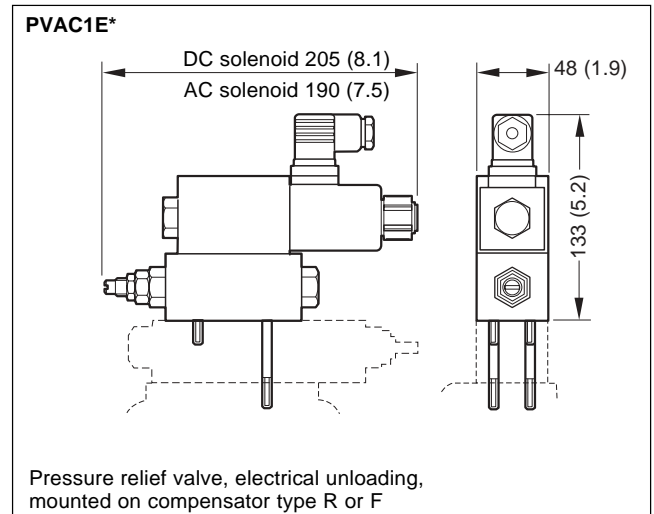
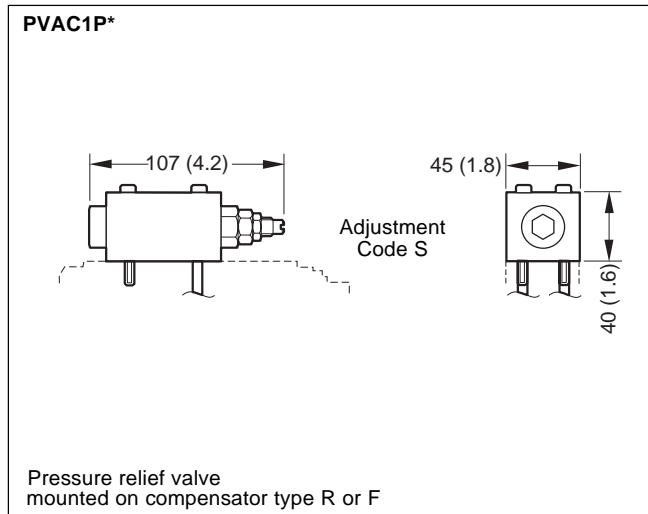

Ordering Examples

1. PV pump with remote pressure control, relief valve with 2 pressure stages, electrical pressure selection, nitrile seals, 24 VDC solenoid, plug to DIN 46350 accessories **fitted**:
PV*****FRZ
PVAC2PCMNSJP

2. Same pump accessories **not fitted**:

PV*****FR1

PVAC2PCMNSJP

3. Usable for horsepower control.

Symbols

PVAC1P*

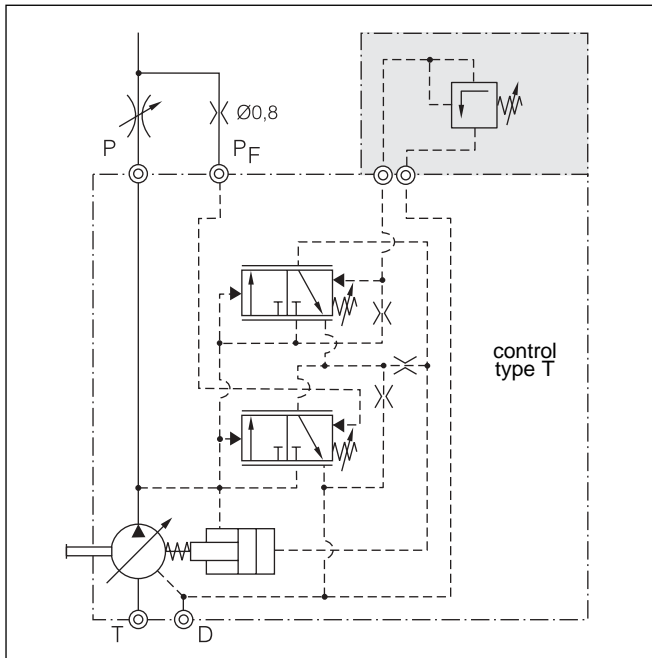

PVAC1E*

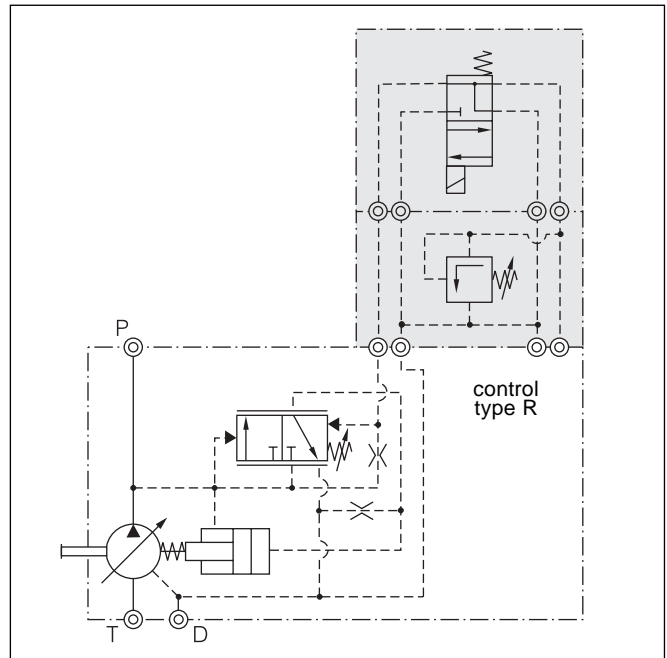

PVAC2P*

see above
ordering example No. 1

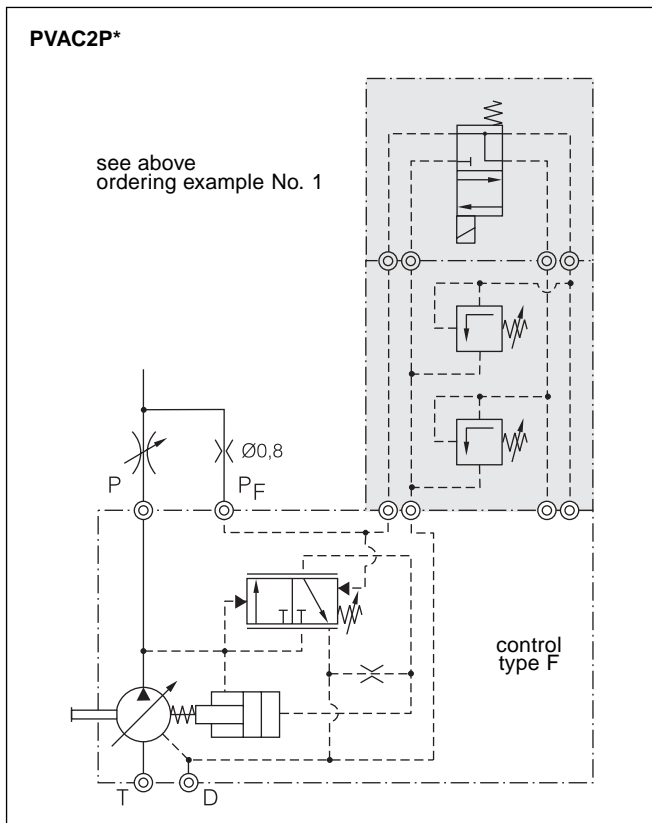

PVAC2M

PVAC2E

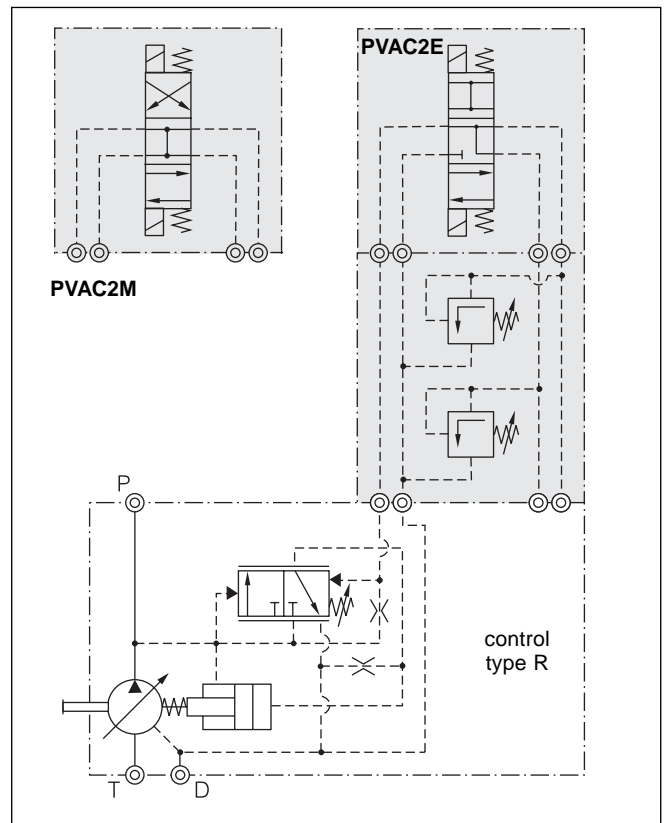

Cross reference ordering codes Parker series PV and Parker series PV plus

Code example PV:

code field no.:

PV	046	R	1	A	1	T	1	N	PWS	XX	YY
1	2	3	4	5	6	7	8	9	10	11	12



PV	Description	Remark	PVplus
Field 1	Pump type		Field 1
PV	Axial piston pump, open circuit, swashplate type, variable displacement		PV

PV	Description	Remark	PVplus
Field 2	Nominal size, displacement		Field 2
016	16 cm ³ /rev displacement		016
020	20 cm ³ /rev displacement		020
023	23 cm ³ /rev displacement		023
028	28 cm ³ /rev displacement	no longer available, in future series PVM up to 250 bar	
032	32 cm ³ /rev displacement		032
040	40 cm ³ /rev displacement		040
046	46 cm ³ /rev displacement		046
063	63 cm ³ /rev displacement		063
080	80 cm ³ /rev displacement		080
092	92 cm ³ /rev displacement		092
130	130 cm ³ /rev displacement	140 cm ³ /rev displacement	140
180	180 cm ³ /rev displacement		180
250	250 cm ³ /rev displacement	270 cm ³ /rev displacement	270

PV	Description	Remark	PVplus
Field 3	Rotation		Field 3
R	clockwise (looking on shaft)		R
L	counter-clockwise (looking on shaft)		L

PV	Description	Remark	PVplus
Field 4	Variation		Field 4
1	standard		1
9	displacement adjusted		9

PV	Description	Remark	PVplus
Field 5	Mounting interface, shaft		Field 5
A	SAE, 2/4-hole, keyed shaft	4 Bolt SAE Pilot, SAE Keyed Shaft	D
B	SAE, 2/4-hole, splined shaft	4 Bolt SAE Pilot, SAE Spline Shaft	E
C	SAE, 4-hole, splined shaft, second pump	no longer available	
D	SAE, 4-hole, keyed shaft		D
E	SAE, 4-hole, splined shaft		E
J	metric, splined shaft, second pump	no longer available	
K	metric, keyed shaft		K
L	metric, splined shaft		L

PV	Description	Remark	PVplus
Field 6	Was: displacement adjustment	Now: ports, threads	Field 6
1	with displacement adjustment	metric, BSPP	1
		SAE, UNF	3
		SAE, ISO 6149	7
		metric, ISO 6149	8

Code example PV:

code field no.:

PV	046	R	1	D	3	T	1	N	FWS	XX	YY
1	2	3	4	5	6	7	8	9	10	11	12

Variable Volume Piston Pumps Parker PV plus vs. Parker PV

Direct Comparison

Cross reference ordering codes Parker series PV and Parker series PV plus

Code example PV:
code field no.:

PV	046	R	1	A	1	T	1	N	PWS	XX	YY
1	2	3	4	5	6	7	8	9	10	11	12

PV		Thru drive and Second Pump Option	PVplus	
Field			Field	
7	8	Description	Remark	
T	1	Thru shaft Capable with Cover	T	1
A	4	2/4 Bolt SAE "A" Pilot 3.25"/SAE "A" 9T Spline Coupler	A	4
B	7	2/4 Bolt SAE "B" Pilot 4.00"/SAE "B" 13T Spline Coupler	B	3
			B*	7
C	8	2/4 Bolt SAE "C" Pilot 5.00"/SAE "C" 14T Spline Coupler	C**	3
			C***	7
H	2	4 Bolt 80mm Pilot/W ? x ? x ? x 8f DIN 5480 Coupler	H	3
J	2	4 Bolt 100mm Pilot/W 25 x 1.5 x 15 x 8f DIN 5480 Coupler	J	3
K	2	4 Bolt 125mm Pilot/W 32 x 1.5 x 20 x 8f DIN 5480 Coupler	K****	3
W	7	2/4 Bolt SAE "B" Pilot 4.00"/SAE "BB" 15T Spline Coupler	W	3
			W	7
Y	7	2 Bolt SAE "AA" Pilot 2.00"/SAE "A" 9T Spline	Y#	7

*Not available with size 1
 **Size 2 or larger
 ***Not available with size 1 and 2
 ****Only available with 032 and larger
 #Only available with size 1

PV	Description	Remark	PVplus
Field 9	Seal material		Field 9
N	NBR		N
V	FPM		V

PV	Description	Remark	PVplus
Field 10	Compensator options		Field 10
**S	standard pressure compensator	only fast response option available	F*S
*RC	remote pressure compensator	only fast response option available	FRC
*R1	remote pressure compensator with D03 interface	only fast response option available	FR1
*F1	load-sensing compensator with D03 interface	only fast response option available	FF1
L	horse power compensator	no longer for load sensing	*L*

PV	Description	Remark	PVplus
Field 11	Design series pump		Field 11
	not required on order		

PV	Description	Remark	PVplus
Field 12	Design series compensator		Field 12
	not required on order		

*Consult Factory for assistance in crossing over PV model codes that are not shown.

Code example PV:
code field no.:

PV	046	R	1	D	3	T	1	N	FWS	XX	YY
1	2	3	4	5	6	7	8	9	10	11	12

Differences in dimensions

***Dimensional Differences only
evident in PV140, 180 & 270.**

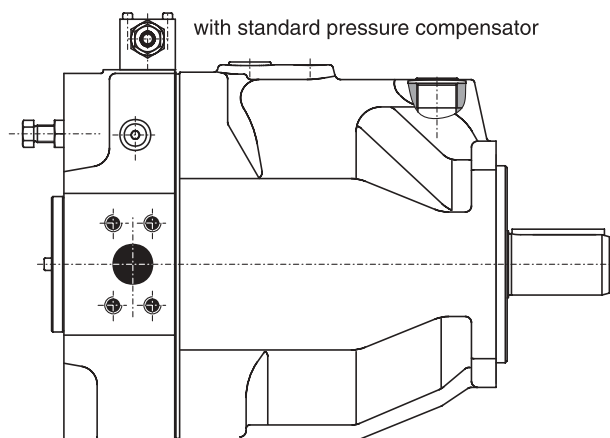
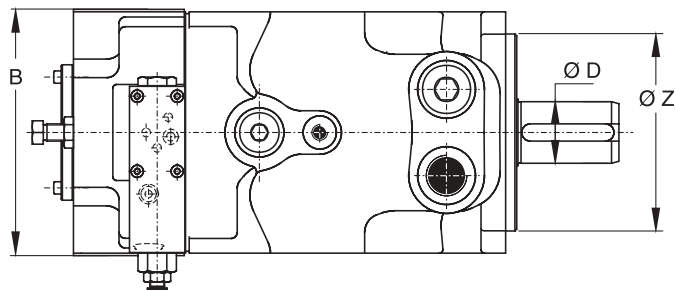

Dimension	PV130, PV180	PV140, PV180	PV250	PV270
Z, metric (mm)	Ø160	Ø 160	Ø 200	Ø 200
D, metr., key (mm)	Ø 50	Ø 50	Ø 65	Ø 65
D, metr., spline	W50x1.25x38	W50x2x24	W62x1.25x48	W60x2x28
Z, SAE (in)	Ø 152.4	Ø 152.4	Ø 165.1	Ø 165.1
D, SAE, key (in)	Ø 50.8	Ø 50.8	Ø 50.8	Ø 50.8
D, SAE, spline (in)	15T8/16DP	15T8/16DP	15T8/16DP	15T8/16DP
B (mm)	200	200	330	250

Series	Model	Displacement cc/rev (in ³ /rev)	Mass kg (lbs)
1	PV016	16 (.98)	19 (42)
	PV020	20 (1.2)	
	PV023	23 (1.4)	
2	PV032	32 (1.9)	30 (66)
	PV040	40 (2.4)	
	PV046	46 (2.8)	
3	PV063	63 (3.8)	60 (132)
	PV080	80 (4.8)	
	PV092	92 (5.6)	
4	PV140	140 (8.5)	90 (198)
	PV180	180 (10.9)	
5	PV270	270 (16.5)	172 (379)

Use of Relief Valve

The use of a relief valve, while not mandatory is recommended in the main circuit to suppress hydraulic shock loads and adds additional system protection.

Fluid Recommendations

Premium quality hydraulic oil with a viscosity range between 150-250 SSU (30-50 cst.) at 100°F (38°C). Normal operating viscosity range between 80-1000 SSU (17-180 cst.). Maximum start-up viscosity is 4000 SSU (1000cst.).

Note: Consult Parker when exceeding 160°F (71°C) operation. Oil should have maximum anti-wear properties, rust and oxidation treatment.

Filtration

For maximum pump and system component life, the system should be protected from contamination at a level not to exceed 125 particles greater than 10 microns per milliliter of fluid. (SAE Class 4/ISO 16/13.) Due to the nature of variable displacement pumps, variations in pump inlet conditions, fluid acceleration losses, system aeration, and duty cycle we do not recommend suction line filters. We do recommend the use of a properly sized, in-tank, suction strainer. Contact your Parker representative for assistance.

Start-Up

On initial start-up, the pump case must be filled with fluid. Pressure adjustments should be reduced and the circuit should be open to permit priming.

Special Installations

Consult your Parker representative for any application requiring the following:

Pressure above rated, drive speed above maximum, indirect drive, fluid other than petroleum oil, fluid temperature above 160°F (71°C)

**Shaft Rotation and Line Up**

Pump and motor shaft alignment must be within .010 TIR maximum, using a standard floating coupling. Please follow coupling manufacturer's recommended installation instructions to prevent end thrust on pump shaft. Turn pump to assure freedom of rotation. Pump and motor must be on a rigid base.

The coupling should be sized to absorb the peak horsepower developed.

Installation and Mounting

When mounting a PV Series Pump, the "case drain" must be on top of the pump. The "case drain" should be a separate line unrestricted to the reservoir and extend below the oil level as far from the inlet as possible. The "case drain" line must not exceed 10 PSI (.69 bar) back pressure.

The "case drain" line should be as large in diameter as possible and as short in length as possible. Suggested maximum line length is 10 ft.

Check that the driving motor rotates in the same direction as indicated by the rotation arrow on the pump.

Wear Protection, Wear Reduction**Wear protection, wear reduction**

Wear protection resp. wear reduction

In hydraulic components there are many gliding contacts partly under high (side) loads. Beside the correct viscosity, which on one hand is responsible for the required supply of lubricating fluid to the gap, on the other hand assures a stable lubricating film, the wear reduction capability of the hydraulic fluid is of major importance.

The describing parameter, the, "Schadenskraftstufe" (load carrying capability), is determined in the FZG-normal test A/8, 3/90 according to DIN 51354 part 2 (gear transmission test rig, 12 defined load steps at 90° C start temperature and 8,3 m/s circumference speed).

Depending on the nominal working pressure the following FZG Numbers is recommended!

nominal pressure bar (PSI)	FZG
80 - 125 (1160 - 1812)	≥ 5
125 - 200 (1812 - 2900)	5 - 6
200 - 250 (2900 - 3625)	7 - 9
250 - 320 (3625 - 4641)	≥ 10
> 320 (4641)	≥ 12

Max pressure limit: 1,25 x nominal pressure

Mineral oils are offered according to DIN 51 524 in different fluid types:

- HL-fluids according to DIN 51 524 part 2, normal working load conditions, FZG 6-10.
- HLP-fluids according to DIN 51 524 part 3, higher working load conditions, FZG > 10.

Modern HLP-fluids today usually come with a FZG >12. They are equipped with wear prohibiting additives, which ensure a high safety of operation under severe working conditions.

A

